



Mallard Pass

Solar Farm

Mallard Pass Solar Farm

Supplementary Trial Trenching Report

Procedural Deadline A (3rd May 2023)

EN010127

EN010127/APP/9.4

Mallard Pass Solar Farm Essendine Rutland & Lincolnshire

Supplementary Archaeological Evaluation

Volume 1: Report text and appendices



for:
LDA Design Consulting Ltd

CA Project: MK0789
CA Site Code: ESMP22
CA Report: MK0789_2

Rutland Accession Number; OAKRM: 2022.49
Lincolnshire Accession Number; LCNCC: 2022.131

April 2023

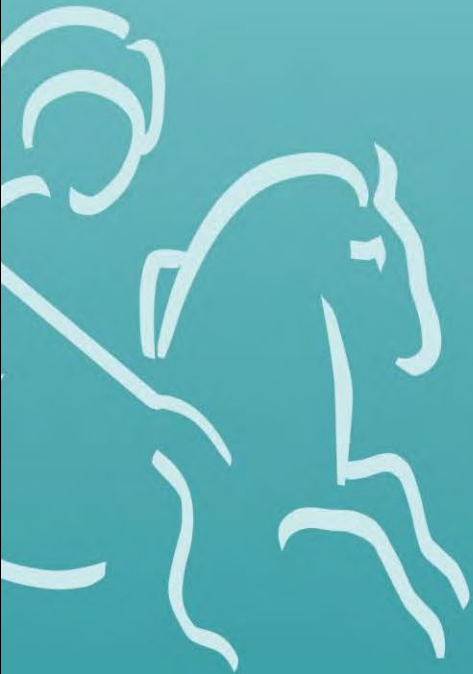

Mallard Pass Solar Farm Essendine Rutland & Lincolnshire

Supplementary Archaeological Evaluation

Volume 1: Report text and appendices

CA Project: MK0789
CA Site Code: ESMP22
CA Report: MK0789_2

Rutland Accession Number; OAKRM: 2022.49
Lincolnshire Accession Number; LCNCC: 2022.131

Document Control Grid						
Revision	Date	Author	Checked by	Status	Reasons for revision	Approved by
1	22.03.2023	Anna Wolf	Adrian Scruby	Draft	–	Adrian Scruby
2	28.04.2023	Anna Wolf	Adrian Scruby	Draft	Client review	Adrian Scruby

This report is confidential to the client. Cotswold Archaeology accepts no responsibility or liability to any third party to whom this report, or any part of it, is made known. Any such party relies upon this report entirely at their own risk. No part of this report may be reproduced by any means without permission.

Cirencester Building 11 Cotswold Business Park Cirencester Gloucestershire GL7 6BQ t. 01285 771 022	Milton Keynes Unit 8, The IO Centre Fingle Drive, Stonebridge Milton Keynes Buckinghamshire MK13 0AT t. 01908 564 660	Andover Stanley House Walworth Road Andover Hampshire SP10 5LH t. 01264 347 630	Suffolk Unit 5, Plot 11 Maitland Road Lion Barn Industrial Estate Needham Market Suffolk IP6 8NZ t. 01449 900 120
e. enquiries@cotswoldarchaeology.co.uk			

CONTENTS

SUMMARY	2
1. INTRODUCTION.....	5
2. ARCHAEOLOGICAL BACKGROUND.....	7
3. AIMS AND OBJECTIVES.....	14
4. METHODOLOGY.....	15
5. RESULTS.....	16
6. THE FINDS	57
7. THE BIOLOGICAL EVIDENCE	81
8. DISCUSSION.....	90
9. CA PROJECT TEAM.....	96
10. REFERENCES.....	96
APPENDIX A: CONTEXT DESCRIPTIONS	104
APPENDIX B: THE FINDS.....	143
APPENDIX C: THE PALAEOENVIRONMENTAL EVIDENCE.....	170
APPENDIX D: OASIS REPORT FORM	175

ILLUSTRATIONS

SEE VOLUME 2 FOR ALL REPORT ILLUSTRATIONS

SUMMARY

Project name:	Mallard Pass Solar Farm
Location:	Essendine, Rutland & Lincolnshire
NGR:	505490 312483
Type:	Evaluation
Date:	20 September – 20 December 2022
Location of Archive:	To be deposited with Rutland County Museum, The Collection Museum (Lincolnshire County Council); and the Archaeology Data Service (ADS)
Accession Number:	Rutland Accession Number - OAKRM: 2022.49 Lincolnshire Accession Number - LCNCC: 2022.131
Site Code:	ESMP22

Between September and December 2022, Cotswold Archaeology carried out a programme of trial trenching of land within the surrounding environs of Essendine, Rutland, extending across the border into the South Kesteven administrative area of Lincolnshire. A total of 209 trenches were excavated, largely targeting anomalies identified by a preceding geophysical survey.

This draft report has been submitted to PINS for onward dissemination to the Local Authority archaeological advisors and at the date of issue has not been reviewed or received comments from the advisors.

An initial interim report on the results of the trial trenching was submitted with the DCO application. The interim noted that a full report including a detailed analysis of the completed fieldwork, which this document represents, would be provided in due course. This full report is based on the same fieldwork reported on in the interim report, providing additional baseline information which supplements the preliminary results previously submitted. The conclusions of the Environmental Statement regarding the baseline characteristics of the investigated areas are not changed as a result of the updated information provided.

The main focal areas of archaeological activity identified by the trenching were accurately predicted by the geophysical survey, particularly in field parcels M6, M10, and PF7. Archaeologically relatively quiet or blank areas indicated by the geophysical survey also were

confirmed as such by the results of the trial trenching. However, not all areas predicted by the geophysical survey to contain archaeological remains did so; for example, trenches 33 – 39, in field parcel M10, contained only a single archaeological feature despite having been targeted at a cluster of anomalies morphologically suggestive of a trackway, enclosures and a possible ring ditch. Similarly, trenches 136, 137 and 138 in land parcel PF8 and trenches 183 – 188 in land parcel N8 also contained no archaeological remains despite the presence of morphologically suggestive geophysical anomalies.

In respect of this, across the majority of the trenching areas high levels of modern plough truncation, plough scarring and evidence for wheel rutting were observed. In field parcel M6 in particular, quantities of artefactual material were noted in the ploughsoil in the vicinity of the trenches, suggesting plough erosion of the underlying remains was actively occurring. Particularly heavy plough scarring was also noted across land parcels P1 and M11. Consequently, it is conjectured that some of the anomalies identified by the geophysical survey, where not clearly related to geological variations etc, may be the result of ploughed-out archaeological features surviving as soil bands in the agricultural plough soil.

The remains encountered in the trenches were shown to be predominantly Iron Age and Roman in date, with little evidence for activity pre- or post-dating these periods being identified. The principal exception to this was a complex of curvilinear ditches and associated features in field parcel M10 (trenches 40, 42 and 45), where a double ring ditch identified by the geophysical survey and targeted by trench 42, appears to be Late Neolithic/ Early Bronze Age in date. Thought on morphological grounds to be a possible burial mound, the absence of any burial pit within the central area of the inner ditch, coupled with evidence for the recutting of both the inner and outer ditch and the presence of pottery and animal bone in the ditches and nearby (seemingly associated) features imply a non-funerary function for the enclosure.

In field parcel M6, an area of Late Iron Age and Early Roman activity was encountered, including a possible stone surface and large quantities of artefacts. The animal bone recovered from this area was dominated by the remains of cattle, almost to the exclusion of other species, consisting exclusively of meat-poor skeletal elements, specifically fragments of the mandible and lower limbs. The bone was well preserved and displayed frequent cut marks; such damage is highly suggestive of the waste from primary butchery where bones that hold little or no meat are removed from the carcass.

A dense area of geophysical anomalies investigated in field parcel PF7 translated into a large number of intercutting ditches, pits, and occupation horizons. The density of features in this area, and the scale and variety of the finds recovered from the features suggest the presence

of a small settlement, possibly a farmstead. Pottery evidence indicates activity at this location from the Late Iron Age onwards, spanning the Iron Age – Roman transition and on into the 3rd – 4th century, although it is not clear if this was truly continuous. In contrast to field parcel M6 the cattle bone consisted of elements from throughout the skeleton, with bones both rich and poor in meat yield recovered in relatively equal amounts. Evidence of butchery was common, with bones displaying heavy chop marks highly suggestive of the waste from secondary butchery where a carcass is separated up into manageable portions of meat.

Further to the south and south-east from land parcel PF7, and in particular across field parcels N7/N8 and N11, a lower level of activity was seen, mostly in the form of possible enclosure and field boundary ditches. However, remains of a possible building of Roman date were encountered in field parcel N7. As with the remains in land parcel PF7, pottery of Late Iron Age, Late Iron Age – Early Roman transition and 3rd – 4th century date was recovered from this area, with pottery of Late Iron Age – Early transitional style/ date recovered from structural postholes suggesting that the building may have been constructed in the 1st century AD. Animal bone recovered from these features was again almost entirely cattle and displayed signs of primary butchery, suggesting the Iron Age – Roman activity in parcels M6 and N8 may represent satellite centres of activity to the main settlement focus in PF7 and were primarily involved in stock raising/ primary butchery, the butchered meat then being consumed at the PF7 settlement.

Although no clear evidence was encountered for the continued occupation of the PF7 settlement and surrounding associated field systems beyond the late Roman period, a small number of pot sherds of possible post-Roman date may indicate a low level of activity continuing into the Saxon period. The area subsequently appears to have formed part of the agricultural landscape surrounding the small medieval settlements at Essendine and Ryhall and continued as agricultural land through the post-medieval and modern periods.

1. INTRODUCTION

- 1.1. Between September and December 2022, Cotswold Archaeology (CA) carried out an archaeological evaluation of land within the surrounding environs of Essendine, Rutland, extending across the border into the South Kesteven administrative area of Lincolnshire (see 1.4 below). The fieldwork was undertaken in order to further assess the Site for areas of significant or complex archaeological remains and followed on from an earlier Heritage Desk-based Assessment (HDBA) and geophysical survey (see Section 2, below).
- 1.2. An application for a Development Consent Order has been submitted for the installation of solar photovoltaic (PV) Modules and associated infrastructure which would allow for the generation and export of electricity at land at Mallard Pass, Essendine. A Scoping Opinion was produced on 18 March 2022 by the Planning Inspectorate (on behalf of the Secretary of State). This stated that a desk-based assessment and geophysical survey of the Site should be undertaken as a minimum, and the need for selective trial trenching should be established with the relevant Local Planning Authority archaeological advisors.
- 1.3. The evaluation was carried out in accordance with a Written Scheme of Investigation (WSI) prepared by CA (2022) submitted to the relevant local planning authorities for review; while the trenching methodology was agreed by the Local Authority archaeological advisors to South Kesteven/ Lincolnshire County Council, the trenching plans accompanying the WSI, dated 13th of September 2022, were not approved. This draft report has been submitted to PINS for onward dissemination to the Local Authority archaeological advisors and at the date of issue has not been reviewed or received comments from the advisors.
- 1.4. The evaluation was carried out in line with the methodology detailed in the WSI, as well as with the *Standard and guidance for archaeological field evaluation* (CIfA 2014; updated October 2020), *Management of Research Projects in the Historic Environment (MoRPHE) PPN 3: Archaeological Excavation* (Historic England 2015) and *Management of Research Projects in the Historic Environment: The MoRPHE Project Managers' Guide* (Historic England 2015).
- 1.5. An initial interim report on the results of the trial trenching was submitted with the DCO application. The interim noted that a full report including a detailed analysis of

the completed fieldwork, which this document represents, would be provided in due course. This full report is based on the same fieldwork reported on in the interim report, providing additional baseline information which supplements the preliminary results previously submitted. The conclusions of the Environmental Statement regarding the baseline characteristics of the investigated areas are not changed as a result of the updated information provided.

The Site

- 1.6. The Solar PV Site and Mitigation and Enhancement Areas comprise a number of separate field parcels/ areas presently in use as arable fields to the north of Ryhall, to the east and west of Essendine in Rutland, and to the west of Braceborough and Greatford, Lincolnshire (hereafter referred to as ‘the Site’; centred at NGR: 505490 312483). The Site occupies a generally flat landscape with gently rolling hills and slight undulations. The elevations within the Site lie at 26m above Ordnance Datum (aOD) toward the village of Essendine, rising to between 32 and 33m aOD within the eastern and south-eastern areas of the Site. Within the western area of the Site the landscape rises to approximately 58m aOD.
- 1.7. The bedrock geology of the Site is comprised of three 3 differing types (BGS 2022). Predominantly within the eastern part of the Site, but also extending towards the centre in areas, are the Kellaways Formation and Oxford Clay Formation – mudstone, siltstone and sandstone, sedimentary bedrock formed approximately 156 – 165 million years ago. Within the centre and western parts of the Site are the Great Oolite Group – sandstone, limestone and argillaceous rocks, and Inferior Oolite Group – limestone, sandstone, siltstone and mudstone. These sedimentary bedrocks were formed approximately 165 to 176 million years ago in the Jurassic Period (BGS 2022).
- 1.8. Superficial deposits are present, predominately within the eastern half of the Site and forming discrete areas (BGS 2022). Alluvium composed of clay, sand and gravels, and sand and gravel River Terrace Deposits, both formed up to 3 million years ago in the Quaternary Period, meander through the village of Essendine out toward Belmesthorpe to the south-east. Further discrete patches of Head deposit, composed of clay, silt, sand and gravels, also formed in the Quaternary period, are present within the centre of the Site. Within the eastern part of the Site recorded superficial deposits comprise patches of Mid Pleistocene Glaciofluvial Deposits composed of sand and

gravels, and Mid Pleistocene Till, consisting of diamicton (terrigenous sediment with particles ranging from clay to boulders) formed up to 2 million years ago in the Quaternary Period within a local environment dominated by ice age conditions.

- 1.9. Borehole samples are recorded within the Site (BGS 2022) and depths of soils and geology are summarised below. Within the south-eastern area of the Site, boreholes undertaken in 1959 recorded 0.3m of soil overlaying river gravels and Oolite Series. To the east of Essendine, boreholes undertaken in 1980 recorded 0.2m of topsoil overlying brown clays with much gravel 0.6m thick, which in turn overlaid firm sandy clays with gravels. To the immediate west of Essendine, boreholes undertaken in 1959 recorded 0.3m of topsoil overlying Upper Estuarine Clays. Boreholes undertaken in 1958 within the furthest western area of the Site recorded 0.15m of soil overlying the Lincolnshire Limestone.
- 1.10. An archaeological excavation undertaken in the centre of the Site recorded topsoil measuring 0.3m in thickness overlaying a subsoil 0.1m to 0.2m thick, which in turn overlaid the natural geology (Dodd 2015).
- 1.11. Geophysical survey (Magnitude Surveys 2022; see below) identified a network of potential paleochannels and large natural anomalies across the Site; the palaeochannels may have drained toward fenland located to the east of the Site.

2. ARCHAEOLOGICAL BACKGROUND

- 2.1. A detailed archaeological background of the Site and surrounding areas, including detailed map regressions and information regarding known archaeological sites and findspots in the wider area, is presented in a Heritage Desk-Based Assessment prepared in support of the scheme (HDBA; CA 2022). Additionally, a programme of geophysical survey has been carried out covering the majority of the proposed development area (Magnitude 2022). The following text represents a summary of these sources.

Palaeolithic

- 2.2. Early prehistoric finds have been identified within recorded palaeochannels towards the centre of the of the Site. Further natural variations were detected across the Site during the geophysical survey (Magnitude Surveys 2022). The survey recorded particularly strong anomalies (variations in the structure of the subsoil indicative of potential human activity) which were interpreted as natural palaeochannels in the

north-west. In addition, a single findspot within the eastern area of the Site comprised a Lower Palaeolithic handaxe.

Mesolithic

- 2.3. The Mesolithic/Neolithic period is represented by flint scatters to the north-east of The Freewards within the centre of the Site, located between two palaeochannels on the valley floor of the West Glen River. The size of the assemblage suggests there was significant Mesolithic/Early Neolithic settlement (Dodd 2015). Further evidence of the Mesolithic and Neolithic periods is located c. 670m to the south of the Site. This activity comprised of concentrations of worked flint and fired clay interpreted as Mesolithic hearths.

Neolithic

- 2.4. Potential Neolithic worked flint was recovered within the centre of the Site, a polished flint axe within the centre of the Site (recorded by the PAS), and to the south, and a Scheduled Neolithic causewayed monument is located c. 180m to the south of the Site. The monument is located in a valley-side location and tilted to overlook the low-lying ground in the valley toward the west (Oswald et al 2001).

Bronze Age

- 2.5. The Site is located within a landscape of known prehistoric funerary activity, with multiple recorded possible Bronze Age barrows, represented as ring-ditches, in the south-east in Field 53, and the centre of the Site in Field 35, and two others recorded to the south of the Site. Two other potential Bronze Age barrow cropmarks are located c. 800m to the east, and c. 180m to the north-east of the Site. Some of these possible barrows have been identified during the recent geophysical survey within the Site, and some as cropmarks with the Site c. 200m to the east of Essendine Castle. While others had already been known from cropmarks noted on aerial photographs outside of the Site boundary. This evidence suggests that the landscape within the centre of the Site formed an important focus for prehistoric funerary activity. Surrounding the possible Bronze Age round barrows (Field 82) to the south and south-west are multiple cropmarks forming enclosures that might be of prehistoric in date possibly associated with these potential barrows. Further Bronze Age and prehistoric activity within the Site comprises findspots of pottery and possible worked flint across the Site. Further Bronze Age activity is recorded immediately adjacent to the Site along the route of proposed highway works and comprises a triple ditch cropmark.

Iron Age

- 2.6. The remains of an unenclosed settlement consisting of three possible structures, pits/postholes and three possible ovens, along with 500 pottery sherds was identified within the centre of the Site, dating to the Late Bronze Age/Early Iron Age (Davies and Parker 2014). The remains of another possible settlement are recorded within the centre of the Site, along with multiple linear and curvilinear ditches surrounding settlement site identified on the geophysical survey. The recorded settlement comprised of pits, post holes, ditches and a possible waterhole dating from the 5th to 2nd centuries BC (Dodd 2015). It might be possible that the two settlement sites form part of a larger singular settlement within this part of the landscape. It must be noted that the Iron Age settlement is located close to the historic route of the West Glen River, located to the immediate north of the settlement's location, therefore the river maybe an indicator as to why the settlement is situated where it is. The undulating flood plain of the former river course is recorded on the LiDAR imagery of the Site, therefore the location of the river may have been a factor in the settlement's location.
- 2.7. Further Iron Age activity within the wider area comprises of a large double-ditched enclosure c. 260m to the south-west of the Site. A watching brief of the installation of a gas pipe recorded features and pottery dating to the Middle Iron Age (Liddle 1983). Late Iron Age settlement remains are located c. 100m from the Site in Great Casterton, comprised of ditches and burials.
- 2.8. Further features, potentially associated with prehistoric or Roman settlement activity, were identified by the geophysical survey. These anomalies were composed of rectilinear enclosures, with linear and curvilinear ditches and possible internal features. The morphology (shape) of these anomalies suggest that they may be the remains of settlements and a wider network of agricultural land divisions.
- 2.9. Within the north-western part of the Site, the geophysical survey identified possible ring ditches and an enclosure (again indicative of the remains of roundhouses and property / field boundaries), features previously identified on air photos. At various other locations across the Site, similar linear and curvilinear anomalies were detected.
- 2.10. Further remains are recorded within the Site and study area which are broadly prehistoric in date. These include: an enclosure and boundary ditch located within the

southern area of the Site, an enclosure c. 150m to the east of the Site, a settlement c. 1km to the east, and a ring ditch c. 500m to the north.

- 2.11. Across the Site the geophysical survey identified multiple areas of possible later prehistoric or Roman period settlement activity (Magnitude Surveys 2022) which were also identified as cropmarks. The survey identified possible remains of a complex of enclosures and agricultural features. Roman period pottery has been recorded to the south of this area and suggests a Romano-British origin for these anomalies (Magnitude Surveys 2022). Further anomalies interpreted as potential enclosures with settlement activity and ring ditches within them were recorded to the south-east of the main activity.

Romano-British

- 2.12. Known recorded Roman period remains within the Site comprise findspots of material including pottery sherds, individual coins and industrial waste. Further findspots of a metal brooch and coin within the wider area are recorded by the PAS around the village of Ryhall c. 1.2km to the south of the Site. The recorded location of the PAS findspots are not accurate but give an indication to Roman activity within the landscape.
- 2.13. A stone sarcophagus was recovered within the eastern area of the Site. The sarcophagus contained a male skeleton with 2 glass vessels and a dish dated to the 4th century (Hurley 1991). The recent geophysical survey of the Site recorded multiple enclosures with internal features close to the findspot of the stone sarcophagus, and therefore could be associated with this possible settlement activity.
- 2.14. Cropmarks of potential Roman in date are located within the Site c. 80m to the east of Essendine Castle. Further recorded Roman settlement activity was recorded c. 1km to the south-west of the Site. This activity comprised of multiple linear ditches interpreted as drainage ditches and flood defences near to the River Gwash, along with ceramic building material indicating the presence of a Roman building nearby (Archaeological Project Services 2007).
- 2.15. Extensive Roman period settlement and activity is recorded to the south-west of the Site, within and around the village of Great Casterton. The settlement began as the fort in the 1st century, located on the north-eastern edge of the current village c.4km to the south-west of the Site, and expanded to become a major settlement spanning

around Ermine Street. It is deduced that this settlement flourished, and it is known that the rampart bank was built on the remains of earlier settlement buildings. During the end of the 2nd century and the beginning of the 3rd century the town wall was built, which from evidence from excavations was 2.1m wide at its base with a 6.5m wide ditch in front of the wall (Great Casterton Parish Council 2022). A villa or farmhouse was built in the 4th century AD c. 400m outside the eastern defences of the town to the north-east. The town and villa were occupied well into the 5th century AD.

Early medieval

- 2.16. One findspot is recorded within the centre of the Site, comprising an Anglo-Saxon pot found during the construction of the Stamford & Essendine Railway in 1868, however the location of the findspot is an approximation based on a contemporary account (Meaney 1964). An early medieval watermill is located c. 870m to the south-west of the Site, but immediately to the south of the A6121 in Ryall.
- 2.17. The remains of an Anglo-Saxon cemetery were encountered during emergency excavation carried out in 1966 due to a road widening scheme on the north-eastern edge of Great Casterton, c.4km to the south-west of the Site. A total of 35 Anglo-Saxon cremations and 15 inhumations were recorded during these works. The burials contained grave goods included an ivory purse ring, 17 bone gaming pieces, a blue-green glass bead, bone combs, copper alloy tweezers, iron tweezers, a miniature iron razor, iron tang fragment, greenish-blue glass vessel, bone beads, an ivory ring, blue glass rod, and an H-shaped iron plate (Leicestershire Archaeological and Historical Society 2015).
- 2.18. The Site is situated within a landscape with multiple settlements recorded in the 1086 Domesday Book, which will usually infer they have early medieval origins. The settlement of Essendine located immediately next to the Site boundary was recorded as having 22 households with 16 villagers, 2 smallholders and 1 slave. The settlement included ploughlands, meadow, woodland and a mill under the lordship of the Bishop of Lincoln (Powell-Smith ND). The origin of the name of Essendine derives from the Old English 'Esa's valley' (University of Nottingham ND).

Medieval

- 2.19. The Site was likely to have been rural in character with dispersed woodland throughout the medieval period, being the agricultural hinterland for the surrounding villages within Rutland and Lincolnshire.
- 2.20. Within the eastern part of the Site is the approximate location of Essendine deer park, associated with Essendine Castle. The park has its origins in the 13th century, but later the park of Essendine was granted to Cecily, Duchess of Warwick, in 1447. It then contained 200 acres of wood, 200 acres of land and 20 acres of meadow (Page 1935). Modern Post-War farming methods have however completely altered the landscape to form very large open flat fields.
- 2.21. Located outside of the Site is the historic settlement core of Essendine. Within this historic core, located c. 60 to the west of the Site is the Scheduled Monument of Essendine Castle, constructed during the late 12th or early 13th century, and the Grade II* Listed Church of St Mary, immediately to the south of the castle, built in the 12th century. The church is said to have been not the parish church but the chapel of castle, in whose bailey the church is sited. Located to the immediate north and south of Essendine Castle are the remains of fishponds which were likely fed by the West Glen River which flows north to south along the boundary of the castle and fishponds. To the immediate east of Essendine Castle is the location of a watermill, which was also mentioned in the Domesday Book, and referred to in the 14th and 15th centuries (Page 1935).
- 2.22. To the immediate west of the Essendine Castle are the cropmarks and earthworks of the medieval village forming a number of pits. There is at least one building site and a possible windmill mound.
- 2.23. To the north-west of the Site at a c. 300m distance is the Scheduled Monument of Castle Dyke (NHLE: 1019097) and Castle Dike Wood. Castle Dyke is the remains of moated manor site with a platform surrounded by a ditch and possibly dates to the 12th century and associated with the deserted medieval village of Aunby nearby.
- 2.24. Extensive ridge and furrow remains are recorded within the Site and the eastern part of the study area, illustrating that previous agricultural remains are present as above ground earthworks around the Site. The ridge and furrow remains within the Site were

identified as part of the recent geophysical survey undertaken in 2022, along with striations related to agricultural activity (Magnitude Surveys 2022).

Post-medieval and modern

- 2.25. The Site and surrounding area appear to have retained an essentially rural character throughout the post-medieval and modern periods.
- 2.26. Remains dating to the post-medieval period are located within the Site. These remains comprise of agricultural features such as ridge and furrow, ditches and field boundaries identified on the accompanying geophysical survey undertaken for the present application (Magnitude Surveys 2022). In addition, within the eastern end of the Site post-medieval settlement remains are present, north of Banthorpe Wood. These remains include possible buildings, ponds and drains identified on the National Mapping Programme, but aerial photography from c. 2000 shows that these features no longer survive as earthworks (CA 2022).
- 2.27. Three railway lines were constructed within the mid-19th century and cross the middle of the Site. The Great North Railway running north-west to south-east was constructed in 1856. Two spurs of the railway line split off the Great North Railway Line and head north and south. The northern route is the former Essendine & Bourne Branch opened in 1860 and went out of use in 1965. The route of the line is preserved within the Site as a hedge line and earthwork to the east of Essendine. The former route of the southern line was Stamford & Essendine Railway that opened in 1856 and was closed in the 1960s also. The railway line is preserved within the Site as a treeline and earthwork also.

Geophysical survey (Magnitude 2022)

- 2.28. The geophysical survey results indicated the presence of probable and possible archaeological features, interpreted as relating most likely to late prehistoric and Roman settlement, agriculture and burial practices. Further anomalies relating to the historical and modern agricultural use of the landscape were also evident across the survey area in the form of ridge and furrow cultivation regimes, modern ploughing trends, mapped former field boundaries and field drains.
- 2.29. The natural geological anomalies identified across the Site may indicate the presence of palaeochannels, particularly within the north-west of the Site, illustrating that the landscape previously contained a greater number of rivers and streams than at

present. These river channels are predominantly located in the central, north-west, north and south parts of the Site in Areas W2 and W3 as well as P1, P2, and P6.

2.30. Archaeological remains identified within the Site by the geophysical survey were located in denser concentrations within the southern, eastern and central areas of the Site. Across the Site the anomalies identified as archaeological remains corresponded with the pattern of cropmarks within the landscape, in particular those which have been identified as possible prehistoric funerary sites, Iron Age settlement and other prehistoric enclosures. Those anomalies within the centre of the Site and where the anomalies were at their densest, in Areas PF7 and PF8, also corresponded with the density of cropmarks within that area interpreted as representing settlement activity. Within the south-eastern area of the Site, particularly in Areas N8 and N11, the geophysical survey identified multiple concentrations of possible settlement activity in the form of enclosures, ring ditches which could be roundhouses, and field divisions. Further ring ditches that may indicate previously unrecorded funerary activity were located within the central eastern area of the Site in Area M10. Other possible prehistoric and/ or Roman enclosures, ring ditches and discrete features were also identified, primarily within the central, southern and eastern areas of the Site. Concentrations of possible enclosures and settlement were located in Area M6, near to Grange Farm within the north-eastern area of the Site, within the area of a previously identified Roman stone sarcophagus.

2.31. Further linear features interpreted as agricultural features, and extensive ridge and furrow were recorded across the Site. These features were anticipated to primarily date from the medieval period onwards.

3. AIMS AND OBJECTIVES

3.1. The specific objective of the evaluation was to investigate potential archaeological features identified by the desk-based assessment, the geophysical survey (Magnitude 2022) and LiDAR data, with a view to confirming the presence/ absence of significant or complex archaeological remains.

3.2. In section 8, below, the results of the evaluation have been assessed with reference to the *East Midlands Historic Environment Research Framework (2020)* in order to place the identified remains within their local and regional contexts, where possible, and to identify any relevant research objectives to which the results may contribute.

4. METHODOLOGY

- 4.1. The evaluation fieldwork comprised the excavation of 209no. trenches, each measuring 50m long by 2m wide, in the locations shown in Figure 2. Each field or land parcel/ area was given a unique identifying code, as also shown on Figure 2. The trenches were located to test anomalies identified through geophysical survey and LIDAR data, as well as apparently blank areas adjacent to anomalies of likely archaeological origin, with the intention of establishing the reliability of the geophysical survey results and confirming the presence/ absence of significant or complex archaeological remains. For trenches in the South Kesteven administrative area, details of the rationale for each trench location were detailed in Appendix B of the WSI (CA 2022).
- 4.2. Trenches were set out on OS National Grid co-ordinates using Leica GPS. Overburden was stripped from the trenches by a mechanical excavator fitted with a toothless grading bucket. All machining was conducted under archaeological supervision to the top of the natural substrate, which was the level at which archaeological features were first encountered.
- 4.3. Archaeological features/deposits were investigated, planned and recorded in accordance with *CA Technical Manual 1: Fieldwork Recording Manual* and the methodology set out in the WSI. All trenches were weathered out and checked thoroughly for any emerging features.
- 4.4. Deposits were assessed for their palaeoenvironmental potential, and samples were taken in accordance with *CA Technical Manual 2: The Taking and Processing of Environmental and Other Samples from Archaeological Sites*.
- 4.5. Artefacts were processed in accordance with *CA Technical Manual 3: Treatment of Finds Immediately after Excavation*.
- 4.6. CA has made arrangements with Rutland County Museum and Lincolnshire County Council Heritage Service for the deposition of the site archive and, subject to agreement with the legal landowner(s), the artefact collection. Confirmation has been obtained from Rutland County Museum and The Collection Museum (Lincolnshire County Council) that the site archive will be split geographically and deposited with the relevant museums under the following accession numbers:

-
- Rutland Accession Number; OAKRM: 2022.49
 - Lincolnshire Accession Number; LCNCC: 2022.131

4.7. A single, combined digital archive will also be prepared and deposited with the Archaeology Data Service (ADS). The archives (museum and digital) will be prepared and deposited in accordance with *Standard and guidance for the creation, compilation, transfer and deposition of archaeological archives* (ClfA 2014; updated October 2020), and any relevant guidelines issued by the recipient museums.

4.8. A summary of information from this project, as set out in Appendix D, will be entered onto the OASIS online database of archaeological projects in Britain.

5. RESULTS

5.1. This section provides an overview of the evaluation results. Detailed summaries of the recorded contexts are given in Appendix A. Details of the artefactual material recovered from the site can be found in Section 6 and Appendix B. Details of the environmental samples (palaeoenvironmental evidence) are given in Section 7 and Appendix C.

5.2. No archaeological features or deposits of any type or period were encountered in trenches 3-4, 7, 10-11, 19, 21-22, 24, 26, 28, 29, 33, 36-39, 41, 43, 46-55, 58-62, 64-66, 68, 70, 74, 76-78, 80, 83-85, 87, 89-93, 97-98, 100, 105-110, 122, 124-126, 132-134, 138, 148-149, 152-157, 160, 163, 165-166, 168, 170, 172-175, 178, 180-181, 183-189, 191, 193-195, 198-199, 202, and 250-208. These trenches will not be discussed in any further detail as part of this report. A selection of blank trench photographs is presented in Figures 22-25.

5.3. Due to the extensive size of the Site, the geological sequence will be discussed separately below for each land parcel.

Areas M6, M7, M10 and M11 (Trenches 1 – 45; Figures 3-8, 26-41)

5.4. The natural substrate in this portion of the Site was encountered at depths between 0.2m and 0.38m and comprised a mixture of mid yellow and red brown sandy clay, with bands of gravel and limestone. This was overlain by topsoil deposits of dark grey brown silty clay. Extensive modern plough truncation was observed across the area.

Trench 1 (Fig. 26-27)

- 5.5. Two intercutting ditches, 102 and 104, were investigated at the eastern end of Trench 1. The earlier feature, 102, measured 1m wide and 0.26m deep, with concave sides and a mostly flat base, and contained a single fill of mid brown red sandy silt, 103. A single sherd of prehistoric pottery as well as animal bone were recovered. The western side of ditch 102 was truncated by later ditch 104, measuring 0.48m wide and 0.24m deep, with steep sides and a concave base. The single fill of mid red brown sandy silt, 105, produced one sherd of earlier prehistoric pottery.
- 5.6. Immediately to the east, pit 106 extended only partially into the trench from the northern limit of excavation. The feature measured 1.22m wide and 0.42m deep, with steep sides and a slightly concave base, and contained a single fill of dark brown sandy silt (107) that produced a small assemblage of animal bone.
- 5.7. North-west/south-east aligned ditch 109 crossed the centre of the trench, measuring 0.3m wide and 0.1m deep with steep sides and a flat base. The fill of mid red brown sandy silt, 110, contained two fragments of prehistoric pottery. A bulk soil sample produced a small assemblage of windblown-dispersed charcoal.
- 5.8. In the western half of the trench, north-east/south-west aligned ditch 111 matched a linear geophysical anomaly forming part of a rectangular enclosure. The ditch measured 1.72m wide and 0.63m deep with steep sides and a narrow, slightly concave base, and contained a single fill of mid grey brown silty clay, 112. Three sherds of Late Iron Age pottery as well as 38 pieces of animal bone were recovered.
- 5.9. At the western end of the trench, possible ditch 113 broadly matched a geophysical anomaly but was only partially exposed within the trench and recorded in plan only. Another potential feature was investigated immediately to the east of ditch 113 and was initially interpreted as being of natural origin. However, the feature corresponded with a substantial linear geophysical anomaly which matches as former field boundary, possibly a hedge line, depicted on the 1888-1913 Ordnance Survey mapping. A continuation of the feature was observed in Trench 2, to the south.

Trench 2 (Fig. 28)

- 5.10. At the north-east end of Trench 2, north-west/south-east aligned ditch 203 broadly matched a linear geophysical anomaly. The ditch measured 1.14m wide and 0.38m deep, with steep sides and a concave base, and contained a lower fill 204 of mid yellow grey silty clay, which was sealed by an upper deposit 205 of dark brown grey silty clay. No finds were recovered. The north-eastern edge of the ditch cut across natural feature 206.
- 5.11. At the southern end of the trench, was undated north/south aligned ditch 210, which measured 2.54m wide and 0.53m deep with steep sides and a slightly concave base. Slumping or deliberate backfill deposits were present to either side of the feature (contexts 211 and 212), bracketing and partially sealed by final deposit 213.
- 5.12. Just to the north-east of ditch 210, a possible feature, 208, was investigated and initially determined to represent a thin naturally accumulated deposit possibly within a natural depression. However, the feature corresponded with a substantial linear geophysical anomaly which matches as former field boundary, possibly a hedge line, depicted on the 1888-1913 Ordnance Survey mapping. The feature was seen to continue to the north through Trench 1.

Trench 5 (Fig. 4)

- 5.13. A single pit 503 was revealed near the north-east end of Trench 5, measuring 1.1m in diameter and 0.19m deep with moderately sloping concave sides and a flat base. The fill, 504, comprising mid grey brown silty clay, produced small quantities of prehistoric pottery, fired clay, and animal bone including one with evidence of burning. A bulk soil sample taken from the fill produced a small assemblage of charred weed seeds alongside a small amount of charcoal, likely representative of windblown/dispersed material.

Trench 6 (Fig. 4)

- 5.14. North/south aligned ditch 603 crossed the north end of Trench 6, matching a linear geophysical anomaly. The feature measured 1.56m wide and 0.51m deep with near-vertical sides and a flat base. A possible slumping deposit or deliberate backfill, 604, comprising mid yellow brown silty sand, was observed on the western side of the ditch, overlain by deposit 605, a mid brown yellow silty sand which in turn was covered by another fill of dark brown grey silty clay (606). The feature was sealed

by upper fill 607, comprising mid orange brown silty clay. No finds were recovered from any of the fills.

Trench 8 (Fig. 29)

- 5.15. Ditch 803 crossed the south-west end of Trench 8 on a north-west/south-east alignment matching a geophysical anomaly which formed part of a large rectangular enclosure. The ditch measured 1.3m wide and 0.6m deep with steep sides and a concave base and contained a lower fill of dark brown silty clay, 804, which produced 36 sherds of 3rd century Roman pottery as well as 10 fragments of animal bone. The lower fill was overlain by an upper deposit of mid red brown sandy silt, 805, which produced four sherds of 3rd century Roman pottery.

Trench 9 (Fig. 30)

- 5.16. Trench 9 revealed a north-east/south-west aligned ditch 903 which matched a linear geophysical anomaly sub-dividing the rectangular enclosure (see Trench 8, above). The ditch measured 1.73m wide and 0.52m deep with steep sides and a concave base. Pottery of 3rd century Roman date was recovered from the single fill of dark grey brown silt clay (904).

Trench 12 (Fig. 31)

- 5.17. In the north-eastern half of Trench 12, a cluster of three pits and a small ditch were revealed. Pit 1202 was investigated by hand excavation while the remaining features were recorded in plan. Pit 1202 measured 0.92m in diameter and 0.2m deep, with moderately sloped sides and a concave base, and contained three fills (1203-1205). The lower deposit, 1203, of mid yellow brown chalky clay was overlain by a second fill, 1204, comprising light brown yellow chalky clay. This in turn was sealed by upper fill 1205, comprising light yellow grey silty clay. No finds were recovered.
- 5.18. At the north-eastern end of the trench, a cluster of shallow possible pits, 1212, 1214, 1216, and 1220, were investigated. While a high level of root disturbance was observed throughout, likely relating to vegetation growing around an adjacent small pond and surrounding trees, a large assemblage of likely later Iron Age and Roman pottery as well as animal bone and ceramic building material was recovered from the features, while further artefactual material was recovered from the topsoil at this end of the trench, suggesting the archaeological remains in this part of the Site are being truncated by agricultural operations.

5.19. At the south-western end of the trench, a broadly north/south aligned ditch, 1218, was investigated, measuring 0.8m wide and 0.27m deep, with moderately sloped sides and a concave base. The feature contained a single fill of mid grey brown silty clay, 1219, which produced no finds.

Trench 13 (Fig. 32-33)

5.20. Two broadly parallel east/west aligned ditches, 1304 and 1316, were investigated within the trench, matching a set of linear anomalies forming part of a sub-rectangular enclosure. Ditch 1304 measured 1.26m wide and 0.24m deep, with moderately sloped sides and a concave base, and contained a lower fill of mid brown orange silty clay, 1305, overlain by an upper deposit of dark brown silty clay, 1306. Pottery of Iron Age to Roman date was recovered from the lower fill, while the upper fill produced an unidentified iron object and five fragments of animal bone. Ditch 1316 measured 0.98m wide and 0.44m deep, with steep sides and a flat base, and contained a single deposit of mid grey brown silty clay, 1317, which produced an additional small assemblage of Iron Age to Early Roman pottery.

5.21. Immediately to the south of ditch 1316, a small pit 1314 was investigated, measuring 0.54m in diameter and 0.3m deep with steep sides and a concave base, and contained a single fill 1315 of mid grey brown silty clay which produced no finds. The feature was seen to truncate the edge of deposit 1312 (see below).

5.22. To the south of ditch 1316, within the interior of the enclosure, a north-west/south-east aligned possible paved track or floor surface, 1311, was encountered, measuring c.1.6m wide and comprising slabs of roughly dressed limestone. Later Iron Age to early Roman pottery was recovered from the silting deposit between the stones, which was also seen to extend further to the north (1312). The possible surface was cut by the north-east/south-west aligned arm of an L-shaped ditch, 1307, measuring 0.46m wide and 0.16m deep, with steep sides and a concave base. This contained a single fill (1308) of dark grey brown silty clay which produced a small quantity of pottery and a single piece of fired clay. Ditch 1307 curved towards the west just south of the possible surface although another small ditch, 1309, was noted extending from the corner of the ditch to the south-west. Ditch 1309 measured 0.42m wide and 0.06m deep, with gently sloped sides and a concave base. A single fill of mid grey brown silty clay, 1310, contained no finds.

Trench 14 (Fig. 5)

- 5.23. A small ditch 1402 was investigated at the eastern end of Trench 14, running on a north/south alignment and measuring 0.64m wide and 0.27m deep, with steep sides and a concave base. The feature contained a single fill of dark grey brown silt clay, 1403, which produced 48 fragments of animal bone.

Trench 15 (Fig. 34-35)

- 5.24. An oval pit 1502 extended into the south-western half of Trench 15 from the south-eastern limit of excavation, measuring 1.64m long, 1.28m wide and 0.17m deep, with steep sides and a flat base. It contained a single fill (1503) of dark grey brown silty clay that produced Roman pottery, animal bone and daub. The feature broadly matched the location, although not the shape of an amorphous geophysical anomaly.
- 5.25. At the south-western end of the trench, pit 1504 measured 0.66m in diameter and 0.25m deep, with steep edges and a concave base. The feature contained a single fill of mid brown grey silty clay (1505) that produced a relatively large assemblage (79 sherds) of Roman pottery along with a small quantity of animal bone.
- 5.26. Ditch 1506 crossed the north-eastern half of the trench on a north-west/south-east alignment matching a linear geophysical anomaly forming part of a sub-rectangular enclosure. The ditch measured 1.96m wide and 0.66m deep, with steep sides and a concave base, and contained two fills (1507-1508). The lower fill, 1507, consisted of a mid yellow brown clayey silt, overlain by an upper deposit of dark brown grey silty clay, 1508. Both deposits produced a variety of artefactual material including burnt and unburnt animal bone, fired clay and pottery of Roman date.

Trench 16 (Fig. 5)

- 5.27. A modern ditch 1602 was investigated in Trench 16, crossing the centre of the trench on a broadly east/west alignment matching a geophysical anomaly. The feature measured 4m wide and 0.48m deep and contained a large concrete pipe which was observed to drain into a small pond to the west. The pipe was covered by a single fill of mid brown grey silty clay (1603) which produced fragments of modern bottle glass and plastic.

Trench 23 (Fig. 7)

- 5.28. A set of intercutting east/west aligned possible ditches (2308, 2313, 2315, and 2317) were revealed at the southern end of Trench 23, matching a linear geophysical anomaly. The number of recuts and scale of the features, measuring between 1.69m and 2.4m wide and up to 0.82m deep, suggests an established, well-maintained boundary. Fill 2311 of ditch 2308 produced two sherds of prehistoric pottery.

Trench 25 (Fig. 36)

- 5.29. Trench 25 revealed two undated parallel north-east/south-west aligned ditches, 2503 and 2510, both corresponding with linear geophysical anomalies. Ditch 2503 measured 3m wide and 1.05m deep, with steep sides and a concave base. The feature contained a total of five fills (2504-2506, 2508-2509) of mixed red and grey brown silt clay material, with a small number of animal bone recovered from secondary fill 2506. Ditch 2510 measured 3.6m wide and 0.45m deep, with steep sides and a concave base, and contained three undated fills of mid yellow brown and mid orange brown silty clay, 2511-2513. A single piece of animal bone was recovered from upper fill 2513, while the basal fill 2511 produced a larger bone assemblage totalling 815g in weight.

Trench 27 (Fig. 37)

- 5.30. Two parallel, broadly north/south aligned ditches, 2703 and 2708, were encountered in Trench 27, spaced c.11m apart and matching linear geophysical anomalies. Ditch 2703 measured 3.68m wide and 0.65m deep, with moderately sloped sides and a concave base, and contained a total of four fills (2704-2707) comprising mixed silting deposits of mid grey brown and light brown silty clay. Secondary fill 2705 produced an unidentified iron object, while animal bone was recovered from tertiary fill 2706 and a heavily fragmented copper alloy crotal bell was recovered from final deposit 2707.
- 5.31. Ditch 2708 measured 2.61m wide and 0.4m deep, with a similar profile to that of 2703. It was filled by a lower deposit of light brown clayey sand (2709) overlain by an upper deposit of light orange brown clayey sand (2710). No finds were recovered.

Trench 30 (Fig. 7)

- 5.32. Trench 30 revealed a single broadly north-west/south-east aligned ditch, 3004, matching a linear geophysical anomaly. The feature measured 1.65m wide and 0.45m deep, with moderately sloped sides and a concave base, and contained three

fills (3004-3007) of mid grey brown and mid yellow brown sandy silt. Fill 3005 produced prehistoric pottery, while a large assemblage of unburnt and burnt animal bone was recovered from fill 3006. Although the geophysical survey indicated a continuation of the feature to the north-west, across Trench 29, no evidence for this was seen in that trench.

Trench 31 (Fig. 7)

- 5.33. Two intercutting ditches, 3103 and 3105, crossed the north-eastern end of Trench 31, running on an east/west alignment matching that of a linear geophysical anomaly and also partially coinciding with part of a curvilinear anomaly. Ditch 3103 measured 1m wide and 0.44m deep, with steep sides and a flat base, and contained a single fill of mid grey brown silty clay (3104). Ditch 3105 measured 0.47m wide and 0.35m deep, with gently sloped sides and a concave base, and was filled by a single deposit of mid grey brown silty sand (3106). No finds were recovered from either feature.

Trench 32 (Fig. 7)

- 5.34. Three intercutting pits were investigated at the south-eastern end of Trench 32. Pit 3204 measured 1.05m wide and 0.18m deep, with concave sides and a concave base, and contained a single fill of mid grey black silty clay (3205). Pit 3206 measured 1.88m wide and 0.45m deep, with moderately sloped sides and a concave base, and was filled by a single deposit of dark grey brown silty clay (3207). Pit 3208 measured 1.48m wide and 0.2m deep, with moderately sloped sides and a flat base, and also contained a dark grey brown silt clay (3209). No finds were recovered from any of the features.

Trench 34 (Fig. 8)

- 5.35. Ditch 3402 crossed the south-eastern half of Trench 34 running on a north-east/south-west alignment. The feature measured 0.67m wide and 0.08m deep, and was filled by a single undated deposit of dark grey brown silty sand (3403). Although a number of north-east/southwest aligned geophysical anomalies were targeted by the trench, ditch 3402 did not correspond with any of these anomalies, while none of the anomalies had a corresponding sub-surface feature.

Trench 35 (Fig. 8)

- 5.36. Two north-west/south-east aligned ditches, 3503 and 3506, crossed the centre of trench 35. Ditch 3503 measured 1.68m wide and 0.72m deep, with moderately sloping sides and a flat base, and contained two fills, 3504-3505. The lower fill, 3504,

comprised a mid orange brown silty sandy, overlain by upper deposit 3505, a dark grey brown silty sand. Ditch 3506 measured 2m wide and 0.6m deep, with a matching profile to ditch 3503, and contained three undated deposits of mid orange brown and dark grey brown silty clay (3507-3509).

Trench 40 (Fig. 38)

- 5.37. In Trench 40, a broadly north/south aligned ditch, 4003, was investigated at the eastern end of the trench. The feature measured 1.57m wide and 0.22m deep, with gently sloped sides and a flat base, and contained an undated fill of light grey brown sandy silt (4004).
- 5.38. Further to the west, north-east/south-west aligned ditch 4005 matched a C-shaped curvilinear anomaly identified by the geophysical survey. The ditch measured 1.46m wide and 0.14m deep, with gently sloped sides and a concave base, and contained a single deposit of light grey brown sandy silt (4006).
- 5.39. In the western half of the trench, pit 4007 extended into the trench from the southern limit of excavation, measuring 2.16m long and 0.78m wide, with a depth of 0.56m. It contained a single fill of dark grey brown silty sand (4008) that contained a large quantity of animal bone (101 pieces), 35 sherds of prehistoric pottery and three pieces of fired clay.

Trench 42 (Fig. 39-40)

- 5.40. Trench 42 targeted the location of two concentric anomalies, revealing two curvilinear ditches in the locations indicated by the geophysical survey. Although root disturbance was observed within all excavated slots, the ditches were generally well-preserved, with the predominantly V-shaped profiles surviving to depths between 0.3m and 0.8m below the existing ground level.
- 5.41. The outer ring ditch, comprising ditch 4208 and recut 4216 at the north-western end of the trench and ditch 4220 at the south-eastern end, measured approximately 30m in diameter, between 2.47m and 3.34m wide and around 1m deep, with steep sides and a narrow, concave base. A broadly consistent sequence of seven fills was observed in both excavated slots. A single sherd of early prehistoric pottery was recovered from fill 4214 of ditch 4208, while the fills of ditch 4220 produced a more varied finds assemblage including a total of 27 fragments of animal bone from fills 4225, 4226, and 4227, fired clay from fills 4226 and 4227, four flint flakes/blades

from fills 4226 and 4227 of likely Mesolithic or Early Neolithic date, and a total of 11 sherds of prehistoric pottery from fills 4226 and 4227 which could not be dated more closely. A bulk soil sample taken from ditch slot 4220 contained a moderate assemblage of charcoal as well as terrestrial snail shells.

- 5.42. A recut (4216) was identified in the north-western section through the outer ring ditch 4208, measuring 1.5m wide and 0.5m deep with steep sides and a concave base. The recut contained a single fill of mid brown grey silty clay (4217) which produced a heavily worn George II halfpenny dating to between 1741-1759 that the excavator considered originated from near the top of the feature and may therefore be intrusive.
- 5.43. The inner ring ditch, comprising ditches 4233/4235 on the north-western side and 4203/4229 to the south-east, measured approximately 17.5m in diameter. The earliest phase of the ditch, recorded as contexts 4229 and 4233, measured approximately 0.5m wide and between 0.26m and 0.46m deep with steep sides and a slightly concave base. A single fill (4230/ 4234 respectively) of mid grey brown to light orange brown silty clay produced three sherds of Iron Age pottery.
- 5.44. As with the outer ring ditch, the inner ring ditch (4229/ 4233) had also been recut, the recut (4235 and 4203) being considerably larger in size than the original ditch, measuring approximately 2.9m wide and between 0.75m and 0.88m deep, with steep sides and a concave base. A sequence of four fills was encountered in slot 4203, while five deposits were observed in slot 4235. A small number of animal bone and three flint blades were recovered from the deposits in ditch section 4203 while a larger animal bone assemblage and one flint flake were recovered from the deposits in ditch section 4235.
- 5.45. Three smaller ditches, ditch 4218 and intercutting ditches 4231/4246, were investigated in the northwest part of the trench, seemingly sharing an association with the ring ditch, which ditch 4218 appeared to pre-date.
- 5.46. Undated ditch 4218, measuring 0.39m wide and 0.4m deep with steep sides and a concave base, was cut by the western edge of ring ditch 4208, indicating an earlier phase of activity. Immediately to the east of ring ditch 4208, intercutting ditches 4231 and 4246 also matched the alignment of the other ditches but a clear relationship with the ring ditches could not be established. Ditch 4231 measured 0.55m wide and

0.35m deep with steep sides and a concave base, and contained a single fill of light orange brown silty clay which produced no finds (4232). The north-western edge of the ditch cut across ditch terminus 4246, which measured 0.53m wide and 0.25m deep, with steep sides and a concave base, and was also undated.

- 5.47. A layer of dark red brown clayey silt (4241) measuring 0.24m thick was observed covering the interior area of the inner ring ditch and was seen to be cut by inner ring ditch recut 4235. The layer covered a small pit, 4249, located at the centre of the trench, measuring 0.66m in diameter and c.0.3m deep, that contained a single sterile fill of dark brown grey silty clay (4250). A bulk soil sample taken from the pit fill produced only a small assemblage of charcoal.

Trench 44 (Fig. 41)

- 5.48. A cluster of five pits was revealed in Trench 44. Pit 4403 extended into the trench from the north-western limit of excavation, measuring 1.28m long, 1.05m wide and 0.8m deep, with steep sides and a flat base. It contained a single fill of mid grey brown silty sandy (4404) that produced a relatively large number of animal bone.
- 5.49. Pit 4405, located immediately to the south-east of 4403, measured 0.9m in diameter and 0.22m deep, with gently sloped sides and a concave base, and contained a single fill of mid brown silty clay (4406). No finds were recovered.
- 5.50. In the north-western half of the trench, pit 4407 measured 0.63m in diameter and 0.3m deep, with concave sides and a concave base. The feature contained a single fill of dark grey brown sandy clay, 4408, that produced ten fragments of Late Neolithic to Early Bronze Age pottery.
- 5.51. Pit 4409 measured 0.96m long and 0.8m wide, with concave sides and a slightly uneven base, and contained a single undated deposit of dark grey brown sandy clay (4410).
- 5.52. Pit 4411 measured 0.43m in diameter and 0.21m deep, with steep sides and a concave base, and was filled by a mid grey brown silty clay (4412) that produced one sherd of pottery.

Trench 45 (Fig. 8)

- 5.53. A large modern quarry pit, 4503, was revealed in Trench 45, measuring 9.9m long and 0.36m deep, with moderately sloped sides and a flat base. The feature

contained a single fill, 4504, dark grey black silty clay. Discussions with the farmer suggest a relatively recent date for the feature, likely relating to the construction of the pedestrian bridge across the railway line to the south.

Areas W1, W2 and W3 (Trenches 46 – 62; Figures 9-11)

- 5.54. The stratigraphic sequence within this portion of the Site was broadly consistent with the natural substrate, comprising a mix of light brown yellow silty clay with lenses of red sandy silt, with frequent bands of gravel and limestone, encountered at depths between 0.27 and 0.34m. This was directly overlain by topsoil deposits of mid grey brown silty clay. With the exception of Trenches 56 and 57, no features were encountered within this portion of the Site, however extensive evidence for modern plough truncation was observed across the area.

Trench 56 (Fig. 11)

- 5.55. In Trench 56 an isolated pit 5602 was investigated, measuring 1.10m in diameter and 0.32m deep with steep sides and a flat base. The feature contained a single sterile fill, 5603, of light grey brown silty sand. No finds were recovered.

Trench 57 (Fig. 10)

- 5.56. In Trench 57, a large rectangular pit 5703 of apparently modern date was revealed, measuring greater than 2m long, 0.7m wide and 0.5m deep, with near-vertical sides and an irregular base. The feature contained a single fill of mid red brown sandy clay (5704). Fragments of modern ceramic field drain as well as plastic were observed within the fill.

Area P1 (Trenches 63 – 67; Figures 11, 42)

- 5.57. The stratigraphic sequence within this part of the Site was broadly consistent, with the natural substrate encountered at depths around 0.3m below existing ground level and comprising a mixture of light to mid brown yellow silt clay. This was overlain by subsoil deposits comprising mid yellow brown silty clay, measuring c.0.1m thick, overlain in turn by topsoil deposits of mid grey brown silty clay.

Trench 63 (Fig. 11)

- 5.58. Trench 63 revealed a cluster of small pits. Pit 6303 extended only partially into the trench from the south-eastern limit of excavation, measuring 1 long, 0.6m wide and 0.2m deep with steep sides and a flat base. A lower fill of mid grey brown silt (6304) was overlain by an upper deposit of mid red brown silt (6305). Fourteen sherds of

prehistoric pottery were recovered from lower fill 6304. A bulk soil sample recovered from the fill also produced a single barley grain as well as charcoal and a variety of terrestrial snail shells.

- 5.59. North-east/south-west aligned small ditch 6306/6308 extended into the trench from the north-western limit of excavation, terminating within the trench. The feature measured 0.2m wide and 0.08m deep with steep sides and a concave base and contained a single undated fill of light red brown silty clay (6307/6309).
- 5.60. The northern edge of ditch 6306/6308 truncated earlier pit 6310, measuring 0.6m long, 0.4m wide and 0.1m deep with concave sides and a concave base. The dark red brown sandy clay fill (6311) produced no finds.
- 5.61. Near the southern end of the trench, pit 6312 was only partially exposed, extending from the northern limit of excavation. The feature measured 0.64m long, 0.27m wide and 0.17m deep with steep sides and a concave base and contained a lower fill of mid brown silty clay, 6313, overlain by an upper deposit of mid red brown silty clay, 6314, neither of which produced dating evidence.
- 5.62. Just to the south, pit 6315 appeared broadly triangular in plan, measuring 1.5m long, 0.9m wide and 0.21m deep with steep sides and an irregular base. The feature was filled by a single sterile deposit of dark brown red sandy silt (6316).

Trench 67 (Fig. 42)

- 5.63. A single east/west aligned ditch was encountered in Trench 67, matching a linear geophysical anomaly forming part of a large possible D-shaped enclosure. The feature measured 2m wide and 0.6m deep with steep sides and a slightly irregular base, and contained a sequence of five fills (6704-6708) comprising mostly deposits of silty clay and silty sand, with fills 6704, 6706 and 6707 possible representing separate events of natural erosion or deliberate infilling. No finds were recovered.

Areas P2, P3, P6, P9-11 and P13-14 (Trenches 68 – 96; Figures 12-14, 43-46)

- 5.64. The stratigraphic sequence within this part of the Site was again broadly consistent, with the natural substrate encountered at depths between 0.26m and 0.37m and comprising a mixture of light to mid brown yellow and red brown silty clay with lenses of blue clay and some bands of chalk, as well as gravel and limestone bands. This was overlain directly by topsoil deposits of mid grey brown silty clay.

Trenches 69 and 71 (Fig. 43)

- 5.65. A broadly north-east/south-west aligned ditch was recorded in plan in Trench 69, matching a geophysical anomaly which continued to the north-east, across Trench 71, where it was investigated as east-west aligned ditch 7102. Ditch 7102 measured 2.55m wide and 1.12m deep, with steep sides and a concave base, and contained a lower fill of mid white brown sandy gravel, 7103 that was overlain by an upper deposit of mid brown silty sand, 7104. Three fragments of possible iron flow slag were recovered from upper fill 7104.

Trench 72 (Fig. 44)

- 5.66. North-west/south-east aligned intercutting ditches 7202 and 7205 were revealed crossing the centre of Trench 72, matching a linear geophysical anomaly. Ditch 7202 measured 1.7m wide and 0.57m deep, with steep sides and a concave base, and contained a sterile lower fill 7203 of mid orange brown silty chalk. This was covered by upper fill 7204, comprising a dark brown grey silty clay that produced a single hand-forged carpentry nail, a fragment of industrial waste and a piece of worked stone. Ditch 7205 measured 1.15m wide and 0.35m deep, with a matching profile to ditch 7202, and contained a single deposit of mid orange brown silty chalk (7206). The features and geophysical anomaly broadly correspond with a historic field boundary shown on the 1888-1913 Ordnance Survey mapping of the area, confirming a relatively recent date for the ditches.
- 5.67. Just to the north-east, large quarry pit 7207 corresponded with a discrete geophysical anomaly and measured 3.4m in diameter and 1.24m deep, with steep sides and a concave base. The feature contained a total of eight distinct fills (7208-7215). Fill 7212 produced a fragment of green bottle glass, as well as animal bone, three iron objects and four pieces of industrial waste. Based on the recovered artefactual material, a post-medieval date is conjectured for this feature.

Trench 73 (Fig. 12)

- 5.68. A single shallow pit was investigated at the north-western end of Trench 73, extending into the trench from the north-eastern limit of excavation. The feature measured 2.93m long, 1.19m wide and 0.3m deep, with moderately sloping sides and an irregular base, and contained three undated fills of mid red brown and light red grey silty clay (7304-7306). No evidence was seen for a feature corresponding

with a north-east/south-west aligned linear geophysical anomaly crossing the centre of the trench.

Trench 75 (Fig. 13)

- 5.69. Trench 75 revealed a north/south aligned ditch corresponding with a linear geophysical anomaly. The feature measured 0.92m wide and 0.14m deep, with moderately sloping sides and an irregular base, and contained a single undated fill of mid orange brown sandy clay (7504).

Trench 79 (Fig. 14)

- 5.70. Ditch 7902 crossed the western part of Trench 79 on a north/south alignment, matching a linear geophysical anomaly. The feature measured 1.92m wide and 0.2m deep, and contained a lower fill of light grey brown sandy clay with red flecks, 7903, overlain by an upper deposit of mid red brown silty clay (7904). Two fragments of industrial waste were recovered from fill 7903.

Trench 81 (Fig. 14)

- 5.71. A single curvilinear ditch, 8103, was observed in Trench 81, broadly matching the location of two linear geophysical anomalies. The feature measured 0.95m wide and 0.17m deep, with steep sides and a concave base, and contained a single fill of mid grey brown silty clay (8104) that produced no finds.

Trench 86 (Fig. 45)

- 5.72. Trench 86 revealed a shallow, plough truncated north-west/south-east aligned ditch, 8602, corresponding with a linear geophysical anomaly. The feature measured 1.5m wide and 0.13m deep, with gently sloping sides and a concave base, and was filled by an undated deposit of mid brown sandy silt (8603).

Trench 88 (Fig. 14)

- 5.73. Trench 88 targeted the location of two parallel north-east/south-west aligned geophysical anomalies. However, only the easternmost anomaly was matched by a sub-surface feature. Ditch 8803 measured 0.87m wide and 0.6m deep, with steep sides and a concave base, and contained a lower fill of light brown yellow silty clay, 8804, overlain by an upper fill of dark grey brown sandy clay (8805). No finds were recovered from either deposit.

Trench 94 (Fig. 14)

- 5.74. A possible small ditch, 9402, was investigated at the north-western end of Trench 94, running broadly north/south. The feature measured 0.45m wide and 0.2m deep, with steep sides and a flat base, and contained a single fill (9403) of light brown grey silty sand which produced three iron nails. It was observed that the feature alignment matched the modern agricultural tram line within this part of the field and it is possible that it represents wheel rutting or other modern disturbance rather than any archaeological activity.

Trench 95 (Fig. 46)

- 5.75. Ditch 9502 crossed the centre of Trench 95 on a north-east/south-west alignment, matching a linear geophysical anomaly. The feature measured 2.6m wide and 0.22m deep, with gently sloped sides and a concave base, and contained a single fill (9503) of mid yellow brown sandy silt which produced no finds.

Trench 96 (Fig. 14)

- 5.76. Ditch 9602 in Trench 96 was aligned north-west/south-east and crossed the trench just to the south-west of a linear geophysical anomaly of matching alignment. The undated feature measured 0.9m wide and 0.36m deep, with steep sides and a flat base, and contained a lower fill of mid brown yellow sandy clay, 9603, overlain by an upper deposit of dark yellow brown sandy clay (9604).

Areas PF1-5, PF7 and PF8 (Trenches 97 – 137; Figures 15-17, 47-70)

- 5.77. The natural substrate in this part of the Site was encountered at depths between 0.3m and 0.4m, comprising light brown yellow and mid brown orange silty clay with bands of limestone and some lenses of blue clay as well as mid red brown sandy silt. This was overlain directly by topsoil deposits of mid grey brown silty clay.
- 5.78. Trenches in this part of the Site were targeted to investigate geophysical anomalies suggestive of Iron Age – Roman settlement, with a particularly dense concentration of anomalies identified in the area around Trenches 112-121.

Trench 97 (Fig. 15)

- 5.79. A possible linear feature was investigated in the trench, broadly matching the westernmost of two parallel linear geophysical anomalies crossing the trench, but was determined to be of natural origin. No evidence of any sub-surface feature was seen to account for the second anomaly.

Trench 99 (Fig. 15)

- 5.80. A north-east/south-west aligned ditch 9903 was encountered in Trench 99, matching a linear geophysical anomaly. The feature measured 1m wide and 0.57m deep, with steep sides and a concave base, and contained an undated fill of mid grey brown silty clay (9904).

Trench 101 (Fig. 47)

- 5.81. A north-east/south-west aligned ditch, 10102, was encountered in Trench 101, matching a linear geophysical anomaly. The feature measured 2.8m wide and in excess of 1m deep, with steep sides. A lower fill of mid grey brown sandy clay, 10104, was overlain by an upper deposit of mid red brown silty clay (10105). Two fragments of animal bone were recovered from upper fill 10105.

Trench 102 (Fig. 15)

- 5.82. A north-east/south-west aligned ditch 10202 was encountered in Trench 102, matching an L-shaped geophysical anomaly which turns towards the south-west to run across Trench 103. The feature measured 1.3m wide and 0.53m deep, with steep sides and a concave base, and contained a single fill of mid orange brown silty clay (10203) which produced a fragment of post-medieval tile and a sherd of early prehistoric pottery.

Trench 103 (Fig. 48)

- 5.83. A north-west/south-east aligned ditch, 10302, was encountered in Trench 103, corresponding with a linear geophysical anomaly that turns towards the north-east to cross Trench 102, where it was investigated as ditch 10203. The feature measured 4m wide and 0.24m deep with gently sloped sides and a concave base and contained a single fill of mid red brown silty clay (10303). A single sherd of Roman pottery was recovered, although CBM of post-medieval date was recovered from the feature in Trench 102 and the date of the ditch therefore remains uncertain.

Trench 104 (Fig. 49-50)

- 5.84. Three parallel broadly east/west aligned ditches were revealed in Trench 104, matching three linear geophysical anomalies.
- 5.85. The northernmost feature, ditch 10403, measured 2m wide and 0.35m deep with moderately sloped sides and a concave base, and contained a single fill of dark red brown silty sand (10404) that produced no finds.

-
- 5.86. Near the centre of the trench was undated ditch 10405, measuring 2.5m wide and 0.25m deep with gently sloped sides and a flat base. The feature contained a lower fill of dark grey brown sandy silt (10406) overlain by an upper deposit of mid brown red silty sand (10407).
- 5.87. Immediately to the south of ditch 10405, a small pit 10408 was also investigated. The feature measured 0.6m in diameter and 0.24m deep with steep sides and a concave base and contained a single undated fill of mid red brown sandy silt, 10409.
- 5.88. At the southern end of the trench, ditch 10410 measured 2.1m wide and 0.28m deep with gently sloped sides and a concave base. The feature contained a single sterile fill of light red brown sandy silt (10411).

Trench 111 (Fig. 51-52)

- 5.89. Four evenly spaced, parallel, north/south aligned linear features were encountered in Trench 111, matching a likely ridge and furrow system identified by the geophysical survey. Two of the features were recorded in plan only, while the other two were subject to hand-excavation.
- 5.90. Furrow 11102, at the eastern end of the trench, measured 2.86m wide and 0.39m deep, with gently sloped sides and a flat base, and contained a single fill of light yellow brown silty clay which contained no finds.
- 5.91. Near the centre of the trench, ditch 11106 measured 2.12m wide and 0.95m deep with steep sides and a flat base, and contained four fills. The lower fill, 11107, comprised light grey red silty clay which produced three fragments of animal bone. This was overlain by a second deposit of light blue grey silty clay, 11108, which was in turn sealed by fill 11109, comprising a mid red brown silty clay. The final, upper fill, 11110, consisted of mid yellow brown silty clay that produced a single fragment of modern pottery. The feature is conjectured to be a former post-medieval field boundary ditch, the alignment of which fossilises/ respects the alignment of the ridge and furrow previously present in this part of the Site.
- 5.92. The eastern side of ditch 11106 was seen to truncate an earlier possible pit (11111), which measured 0.4m wide and 0.35m deep with near-vertical sides and a convex base and contained a single fill of light yellow brown silty clay (11112). No finds were recovered.

Trench 112 (Fig. 53)

- 5.93. Two parallel east/west aligned ditches, 11203 and 11206, were investigated in Trench 112, both matching linear geophysical anomalies. Ditch 11203 measured 1.5m wide and 0.59m deep, with steep sides and a concave base. It contained two fills, 11204-11205, with sterile lower fill 11204 comprising a light grey brown silty clay that was covered by upper deposit 11205, a dark grey brown silty clay which produced animal bone and pottery of late-3rd to 4th century date.
- 5.94. Ditch 11206, to the south, measured 0.98m wide and 0.18m deep, with steep sides and a concave base, and contained a single fill (11207) of dark grey brown silty sand that contained two fragments of industrial waste and three sherds of late-3rd to 4th century pottery. The southern edge of ditch 11206 truncated a small pit (11208), surviving to a width of 0.54m and a depth of 0.18m and containing a single deposit of mid grey brown silty sand (11209) that also produced pottery of 3rd to 4th century date. At the south-western end of the trench a possible linear feature was only partially exposed and recorded in plan only, matching a wide north/south aligned geophysical anomaly.

Trench 113 (Fig. 54-55)

- 5.95. At the south-west end of the trench, ditch 11303 was only partially exposed, matching a broadly north/south aligned linear geophysical anomaly. As seen, the feature measured 1.82m wide and 0.42m deep, with steep sides and a flat base, and contained a single fill (11304) of dark brown grey silty clay containing animal bone and 3rd century pottery.
- 5.96. To the east, north/south aligned ditch 11307 extended into the trench from the southern limit of excavation before terminating. The feature measured 0.33m wide and 0.26m deep, with steep sides and a concave base, and contained a single fill of dark brown grey silty clay (11308). No finds were recovered.
- 5.97. Ditch 11311 crossed the trench on a north/south alignment matching a geophysical anomaly. Measuring 1.8m wide and 0.73m deep with steep sides and a concave base, it contained a lower fill (11312) of mid brown orange clayey sand, which was overlain by an upper deposit (11313) of dark brown grey silty clay that produced animal bone, two iron nails and pottery of late-3rd to 4th century date. The eastern edge of ditch 11311 truncated an earlier pit (11309), measuring 0.8m in diameter

and 0.38m deep, with steep sides and a concave base. The pit contained a single fill of mid brown grey silty clay, 11310, which produced pottery of Roman date.

- 5.98. A total of five intercutting ditches (11324, 11328, 11330, 11332 and 11340) and two pits (11336 and 11338) were revealed at the centre of the trench, all on a north-west/south-east alignment and not clearly matching with any geophysical anomaly. The north-eastern edge of ditch 11324 was seen to truncate north-east/south-west aligned ditch 11322. All features measured between 0.3m and 0.6m deep, with broadly similar profiles comprising steep sides and flat bases. A total of 26 fragments of burnt and unburnt animal bone were recovered from fill 11326, while fill 11325 produced pottery of Mid to Late Iron Age date and fill 11331 produced 3rd-4th century pottery.
- 5.99. Two other north-west/south-east aligned ditches (11341 and 11342) were revealed immediately to the north-east and recorded in plan only. Ditch 11341 appeared in plan to be cut by ditch 11322.
- 5.100. In the north-east portion of the trench two pits, 11305 and 11314, were encountered. Pit 11305 measured 0.5m in diameter and 0.2m deep, with steep sides and a flat base, and contained an undated fill of light brown grey silty clay (11306). No finds were recovered. Pit 11314 measured 0.31m wide and 0.27m deep, with steep sides and a concave base. It contained a single fill of dark brown grey silty clay, 11315, which produced 20 sherds of 3rd century Roman pottery.
- 5.101. At the north-east end of the trench, north-west/south-east aligned ditch 11318 broadly matched a linear geophysical anomaly. Measuring 1.02m wide and 0.12m deep with gently sloped sides and a flat base, it contained a single fill of dark grey brown silty clay (11319) that produced small quantities of animal bone, CBM and pottery. The south-western edge of the ditch truncated earlier elongated pit 11320, measuring 0.32m wide and 0.12m deep with gently sloped sides and a concave base. The feature contained a single fill of dark brown grey silty clay (11321) which produced small amounts of pottery and tile. The north-eastern edge of ditch 11318 was in turn truncated by oval pit 11316, measuring 1.25m long, 0.31m wide and 0.27m deep with steep sides and a concave base. The pit contained an undated fill of mid grey brown clayey silt, 11317.

Trench 114 (Fig. 56-57)

- 5.102. A large ditch 11406 crossed the centre of the trench on a north-east/south-west alignment matching a linear geophysical anomaly. The ditch measured 5.02m wide and 0.5m deep, with steep sides and a concave base, and contained a total of seven fills (11407-11413) that produced a large and varied finds assemblage including animal bone, 3rd-4th century Roman pottery, fired clay, oyster shell, seven iron nails and a copper alloy radiate coin of the Gallic emperor Victorinus (dated to between AD269-271). A bulk soil sample taken from fill 11413 included charred cereal grains as well as weed seeds, charcoal and terrestrial snail shells. The charred remains were considered likely to represent a small dump of food production waste material.
- 5.103. A possible earlier ditch (11403) was observed in the base of ditch 11406, measuring 0.94m wide and 0.54m deep, with steep sides and a concave base. The feature contained a lower fill of mid grey sandy silt, 11404, which was covered by an upper deposit of mid yellow grey sandy silt (11405). No finds were recovered.
- 5.104. At the eastern end of the trench, intercutting ditches 11414 and 11416 were investigated. Ditch 11414, the later of the two features, was aligned broadly north/south, matching a geophysical anomaly, and measured 1.94m wide and 0.66m deep with gently sloped sides and a concave base. The feature contained a single fill of mid brown silty clay (11415) which produced animal bone and two sherds of mid-2nd to 3rd century Roman pottery. The eastern edge of ditch 11414 truncated ditch 11416, which extended into the trench from the north before terminating. The ditch measured 0.96m wide and 0.45m deep, with steep sides and a concave base, and contained an undated fill of dark brown silty clay (11417).
- 5.105. Two pits (11421 and 11423) located to either side of ditch 11414, were recorded in plan only.
- 5.106. At the western end of the trench, broadly east/west aligned ditch 11418 matched a geophysical anomaly. Measuring 0.3m wide and 0.12m deep, with steep sides and a concave base, it contained a single fill of dark brown black silty clay (11419) that produced pottery, animal bone and an iron nail.
- 5.107. A north-west/south-east aligned ditch, 11920, was encountered in the eastern half of the trench and recorded in plan only, matching a geophysical anomaly.

Trench 115 (Fig. 58-59)

- 5.108. At the southern end of trench 115, east/west aligned ditch 11503 measured 0.85m wide and 0.15m deep, with gently sloped sides and a concave base. The feature contained a single fill of dark yellow brown clayey silt (11504) which produced no finds.
- 5.109. To the north, intercutting ditches 11505, 11508 and 11510 were aligned north-west/south-east, matching a linear geophysical anomaly. Ditch 11505, the earliest feature, measured 4.4m wide and 0.6m deep with moderately steep sides and a flat base, and contained an undated lower fill (11506) of dark red brown clayey silt, overlain by an upper deposit of mid grey brown silty clay (11507) which produced 27 sherds of Middle Iron Age pottery, and two fragments of industrial waste. A bulk soil sample taken from the fill only contained a number of terrestrial snail shells.
- 5.110. The feature was truncated by later ditch 11508, measuring 1.2m wide and 0.3m deep with gently sloped sides and a flat base. The ditch contained a fill of mid grey brown clayey silt, 11509.
- 5.111. Ditch 11508 was cut in turn by ditch 11510, measuring 1.06m wide and 0.28m deep with moderately steep sides and a concave base. The feature contained a light yellow brown silty clay fill (11511) which produced animal bone and single sherd of Mid to Late Iron Age pottery.
- 5.112. At the centre of the trench, a north-west/south-east aligned linear feature 11512 was investigated, measuring 1m wide and 0.2m deep, with gently sloped sides and a flat base. The feature contained a single undated fill of mid brown grey silty clay (11513).
- 5.113. A circular pit 11519 was partially exposed within the trench immediately to the north of linear feature 11512 and recorded in plan only.
- 5.114. Ditch 11514 was only partially exposed within the trench, extending from the north-western limit of excavation and matching a sinuous geophysical anomaly forming part of a possible sub-rectangular enclosure. The feature's visible extent measured 1.1m wide and 0.68m deep, with steep sides and a concave base. A sequence of four fills (11515-11518) was observed, comprising deposits of mid yellow brown and dark grey brown silty clay. Animal bone and pottery of 3rd to 4th century date were recovered from contexts 11516 and 11515 respectively.

-
- 5.115. A possible continuation of the same feature, matching the same geophysical anomaly, was encountered immediately to the north and recorded in plan only.

Trench 116 (Fig. 60-61)

- 5.116. The majority of Trench 116 was covered by two large deposits/ spreads (11607 and 11608). Near the centre of the trench, ditch 11603 was aligned east/west, truncating spread 11607, and corresponding with a geophysical anomaly. The feature measured 2.8m wide and 0.52m deep, with moderately steep sides and a flat base, and contained a sequence of three fills (11604-11606) of mid grey brown and light yellow brown sandy clay. Seventy-three fragments of animal bone and an iron nail were recovered from lower fill 11604, while animal bone and pottery of 3rd to 4th century date was recovered from upper fill 11606.
- 5.117. In the south-eastern portion of the trench, deposit layers 11607, 11608 and 11618 were seen to cover intercutting features 11609 and 11612. Ditch 11612, the earlier of the two features, broadly corresponded with a linear geophysical anomaly and measured 3m wide and in excess of 0.6m deep; the base was not reached due to safety concerns. The feature contained a total of five fills, 11611-11617, which produced animal bone and Roman pottery. A number of cereal grains and aquatic and terrestrial snail shells were also recovered from a bulk soil sample.
- 5.118. The southern edge of ditch 11612 was truncated by later pit 11609, measuring 1.8m in diameter and greater than 0.64m deep (the base was not reached). The pit contained a lower fill of mid brown grey silty clay (11611) which produced animal bone and three sherds of Iron Age or Roman pottery, overlain by an undated upper deposit of mid grey brown silty clay (11610).

Trench 117 (Fig. 62-63)

- 5.119. Near the centre of Trench 117, broadly north/south aligned intercutting ditches 11703 and 11705 matched a linear geophysical anomaly forming part of a sub-square enclosure. Ditch 11703 measured 1.96m wide with moderately sloped sides and a concave base, and contained a single fill of dark grey brown silty clay (11704). Ditch 11705 measured 1.87m wide with steep sides and a flat base, and contained a lower fill of dark grey brown silty clay (11706) that produced animal bone and Roman pottery. This was overlain by upper fill 11707, an undated mid orange brown silty clay.

-
- 5.120. In the north-western half of the trench, north-south aligned ditch 11708 extended into the trench from the southern limit of excavation before terminating. The feature measured 0.35m wide with steep sides and a slightly undulating base and contained a single deposit of dark red brown silty clay containing burnt and unburnt animal bone and two fragments of Iron Age pottery (11709).
- 5.121. At the south-eastern end of the trench, north-east/south-west aligned ditch 11710 extended across the trench, measuring 1.21m wide with slightly convex sides and a flat base, and contained a single fill 11711 dark grey brown silty clay with yellow flecks. No finds were recovered.

Trench 118 (Fig. 17)

- 5.122. In the northern half of Trench 118, broadly east/west aligned intercutting ditches 11803 and 11806 were located just to the south of a linear geophysical anomaly on the same alignment. Ditch 11803 measured 2.16m wide and 0.76m deep, with steep sides and a concave base, and contained two fills, 11804-11805, that both produced Late Iron Age pottery. A small number of charred seeds and a single nutlet fragment were recovered from a bulk soil sample, together with charcoal. Ditch 11806 measured 1.37m wide and 0.6m deep, with steep sides and a concave base, and contained three fills, 11807-11809, consisting of mid grey brown and dark black sandy silt. Thirty-two pieces of Iron Age pottery were recovered from fill 11808 as well as a small assemblage of animal bone from fill 11809.
- 5.123. Immediately to the north, ditch 11815 matched the alignment of a geophysical anomaly. Measuring 1.55m wide and 0.3m deep with gently sloping sides and a concave base, the feature contained a single fill of mid grey brown sandy silt (11816).
- 5.124. At the northern end of the trench, north-east/south-west aligned curvilinear ditch 11810 measured 0.38m wide and 0.38m deep with steep sides and a concave base. It contained an undated fill of mid orange brown silty clay (11811).
- 5.125. Immediately to the south, ditch 11812 was aligned north-west/south-east, measuring 0.65m wide and 0.27m deep with steep sides and a concave base. It contained a sterile lower fill of mid grey brown silty clay (11813) overlain by an upper deposit of dark grey brown silty clay (11814) which produced animal bone and a single sherd of Iron Age pottery.

5.126. The southern half of Trench 118 contained a large deposit/spread c.18m in length which was recorded in plan only.

Trench 119 (Fig. 64-65)

- 5.127. Near the centre of Trench 119, broadly north/south aligned intercutting ditches 11903 and 11905 matched a linear geophysical anomaly. Ditch 11903 measured 2.25m wide and 0.46m deep with steep sides and an irregular base, and contained a single fill of light orange brown sandy clay (11904) which produced two fragments of 1st century Roman pottery. Ditch 11905 measured 1.65m wide and 0.46m deep, with a matching profile to ditch 11903, and contained a dark brown sandy silt (11906) from which animal bone, a flint flake and six sherds of Late Iron Age to Early Roman pottery were recovered.
- 5.128. Immediately to the west, north/south aligned ditch 11907 matched a geophysical anomaly forming part of a sub-square enclosure. Measuring 1.57m wide and 0.52m deep with moderately sloped sides and a concave base, the feature contained a sterile lower fill of mid brown silty clay, 11909, overlain by an upper deposit (11908) containing a small quantity of animal bone and six sherds of Late Iron Age pottery.
- 5.129. In the western half of the trench, north-west/south-east aligned ditch 11910 measured 0.8m wide and 0.27m deep with steep sides and an uneven base; it contained a single undated fill of mid grey brown silty clay (11911).
- 5.130. Near the western end of the trench, circular pit 11916 was investigated, measuring 0.6m in diameter and 0.23m deep, with gently sloped sides and a concave base. The undated fill of light brown sandy silt (11917) contained no finds.
- 5.131. In the eastern half of the trench two other pits were also investigated. Pit 11912 was only partially exposed within the trench and measured 2.5m in diameter and 0.1m deep as seen, with gently sloping sides and a flat base. The single fill of mid brown sandy clay (11913) produced small quantities of animal bone, fired clay, and Iron Age pottery.
- 5.132. Pit 11914 measured 1.43m in diameter and 0.31m deep, with gently sloping sides and a concave base. It contained a fill of mid brown sandy silt (11915) from which a single piece of industrial waste was recovered, alongside a virtually complete articulated cow skeleton (see Section 7, below).

Trench 120 (Fig. 17)

- 5.133. A broadly east/west aligned ditch 12003 crossed the southern half of Trench 120, measuring 0.62m wide and 0.38m deep, with steep sides and a concave base. The feature contained a single fill of mid grey brown silty clay (12004) which produced two sherds of prehistoric pottery.
- 5.134. In the northern half of the trench an area of root disturbance was observed, and tree throw 12005 was tested by hand excavation; measuring 0.8m wide and 0.27m deep, with an irregular profile, it contained a single fill of mid grey brown silty clay (12006).

Trench 121 (Fig. 66-67)

- 5.135. A north-east/south-west aligned ditch 12103 was investigated in the eastern half of Trench 121, measuring 1.6m wide and 0.65m deep with steep sides and a concave base. The feature contained three deposits of mid yellow brown to dark grey brown silty clay, contexts 12104 – 12106 respectively, with animal bone recovered from basal fill 12104.
- 5.136. Just to the west, north/south aligned intercutting ditches 12109 and 12112 were broadly aligned with a linear geophysical anomaly. Ditch 12109 measured 1.18m wide and 0.6m deep with steep sides and a concave base and contained a lower fill of mid brown orange clayey sand, 12110, overlain by an upper deposit of dark grey brown clayey sand, 12111, which produced two fragments each of animal bone and Iron Age to Roman pottery. No finds were recovered from the feature. Ditch 12112 measured 0.32m wide and 0.26m deep, with steep sides and a flat base, and was filled by a single deposit 12113 of light grey brown clayey sand which also produced no finds.
- 5.137. At the western end of the trench, pit 12107 was partially exposed, extending from the southern limit of excavation. Measuring 1.57m long and 1.43m wide, with a depth of 0.18m, gently sloping sides and a concave base, the single fill of mid grey brown clayey sand (12108) produced no finds.

Trench 123 (Fig. 17)

- 5.138. One broadly east-west aligned ditch, 12302, was revealed in Trench 123, matching the northern side of a small square enclosure identified by the geophysical survey. The ditch measured 0.7m wide, with concave sides and a concave base and

contained a single fill of mid red brown silty clay (12303) single sherd of prehistoric pottery was recovered.

Trench 127 (Fig. 17)

- 5.139. A north-east/south-west aligned ditch 12703 was identified in the south-eastern half of Trench 127, matching part of an L-shaped geophysical anomaly. The feature measured 1.82m wide and 0.46m deep with moderately steep sides and a flat base and contained a single fill 12704 of light red brown silty clay which produced no finds.
- 5.140. The return of the L-shaped geophysical anomaly was encountered to the north-west, in the form of broadly east/west aligned ditch 12705, measuring 0.9m wide and 0.43m deep with steep sides and a flat base. The feature contained a single fill 12706 of light red brown silty clay which produced 11 fragments of animal bone and one sherd of prehistoric pottery.
- 5.141. Approximately 5m to the north-west, another north-east/south-west aligned ditch 12707 was encountered; this was recorded in plan only. The feature did not match any geophysical anomaly.

Trench 128 (Fig. 17)

- 5.142. A single east/west aligned ditch, 12802, was revealed at the south-eastern end of Trench 128, matching the northern side of a small square enclosure identified by the geophysical survey. Ditch 12802 measured 0.87m wide and 0.18m deep, with gently sloped sides and a flat base, and contained a single fill 12803 of mid grey brown silty clay. A single fragment of animal bone was recovered, along with one fragment of prehistoric pottery.

Trench 129 (Fig. 68)

- 5.143. Trench 129 revealed a curvilinear ditch 12902 just to the south of a curvilinear geophysical anomaly. The feature measured 0.75m wide and 0.22m deep, with moderately sloped sides and a flat base, and contained a single fill 12903 of mid grey brown silty clay. A single fragment of prehistoric pottery was recovered.
- 5.144. Immediately to the south-west, an oval pit 12904 was investigated, measuring 1.34m long, 0.94m wide and 0.22m deep, with moderately sloped sides and a concave base. The feature was filled by a single deposit 12905 of mid red brown silty clay which produced no finds.

-
- 5.145. At the south-western end of the trench, a north-west/south-east aligned ditch 12906 was recorded in plan only, possibly representing the return of ditch 12902.

Trench 130 (Fig. 69)

- 5.146. Trench 130 revealed two ditches which corresponded with two sides of a small square enclosure identified by the geophysical survey. Ditch 13002 was aligned east/west, forming the enclosure's northern side, and measured 0.65m wide and 0.25m deep with moderately sloped sides and a concave base. The feature contained a single fill, 13003 mid red brown silty clay which produced no finds.
- 5.147. Ditch 13004 was aligned north/south, forming the western side of the enclosure, and measured 0.88m wide and 0.24m deep with steep sides and a concave base. The ditch contained one fill, 13005, comprising mid red brown silty clay, which produced two sherds of prehistoric pottery.

Trench 131 (Fig. 17)

- 5.148. At the southern end of Trench 131, an east/west aligned possible furrow, 13102, was encountered. The feature measured 0.83m wide, with gently sloped sides and a flat base, and contained a single fill 13103 of dark brown grey silty clay. Fragments of modern plastic were observed within the fill.

Trench 135 (Fig. 17)

- 5.149. Two parallel broadly north/south aligned ditches (13503 and 13505) were encountered in Trench 135, broadly aligning with geophysical anomalies. Ditch 13503 measured 1.2m wide and 0.2m deep, with steep sides and a flat base, and contained a single fill 13504 of mid brown black silty clay. No finds were recovered.
- 5.150. Just to the west, ditch 13505 measured 0.67m wide and 0.3m deep with steep sides and a flat base. The feature contained a single fill 13506 of mid brown silty clay which produced no finds.

Trench 136 (Fig. 70)

- 5.151. North-east/south-west aligned ditch 13603 broadly matched a linear geophysical anomaly forming part of a possible enclosure system. The feature measured 1.35m wide and 0.16m deep with gradually sloped sides and a concave base, and contained a total of three fills (13604-13606) of mid to dark grey brown silty clay. A total of 16

fragments of industrial waste and three sherds of 2nd century or later pottery were recovered from fill 13605.

Trench 137 (Fig. 17)

- 5.152. Ditch 13703 extended into the trench from the southern limit of excavation, running broadly north-east/south-west before terminating within the trench. The feature broadly matched a linear geophysical anomaly forming part of a possible enclosure system, measuring 0.5m wide and 0.1m deep with gently sloped sides and a concave base, and contained a single fill 13704 of dark grey brown sandy clay. A single fragment of ceramic building material was recovered.

Areas N3, N6-8, N11 (Trenches 139 – 209; Figures 18-21, 71-84)

- 5.153. The stratigraphic sequence in this portion of the Site was broadly consistent, with the natural encountered at depths between 0.4m and 0.6m, comprising predominantly mid orange yellow clayey sand with bands of limestone bedrock. In trenches 139-144, 146-157, 166, 178, 190-192, 195, 197-199 and 209, the natural was overlain by subsoil deposits of mid red brown silty clay measuring between 0.1m and 0.17m thick. All trenches were sealed by topsoil deposits of mid grey brown silty clay measuring between 0.2m and 0.45m thick.
- 5.154. Trenches in this area were targeted to investigate geophysical anomalies as well as apparently blank areas.

Trench 139 (Fig. 18)

- 5.155. A north-west/south-east aligned ditch 13903 was encountered within the trench, matching a linear geophysical anomaly. The ditch measured 1.26m wide and 0.34m deep with steep sides and a concave base and contained a single fill 13904 of mid brown sandy silt. No finds were recovered.

Trench 140 (Fig. 18)

- 5.156. At the north-west end of the trench, a possible pit or natural feature 14002 was investigated, measuring 0.8m long, 0.7m wide and 0.13m deep with near-vertical sides and a flat base. A single fill (14003) of mid grey orange gravelly sand contained no finds.
- 5.157. Immediately to the south, east/west aligned ditch 14009 measured 1.7m wide and 0.39m deep with moderately sloped sides and a concave base. The feature contained

a lower fill (14010) of mid yellow brown silt which produced a single sherd of earlier prehistoric pottery, overlain by a sterile upper deposit of mid yellow brown sandy silt (14011).

- 5.158. Ditch 14012 crossed the north-west half of the trench on a north-east/south-west alignment, measuring 0.95m wide and 0.34m deep with gently sloped convex sides and a concave base. The feature was filled by a single deposit of mid brown sandy silt (14013) which produced a small quantity of animal bone.
- 5.159. Immediately to the south, intercutting pits 14014 and 14017 extended only partially into the trench from the south-western limit of excavation. The earlier feature, pit 14014, measured 1.3m long, 1.2m wide and 0.43m deep with steep sides and a concave base. A lower fill of mid grey brown silt (14016) produced four fragments of industrial waste and was overlain by an upper deposit 14015 of mid brown silt which produced a single iron nail.
- 5.160. The northern edge of pit 14014 was truncated by later pit 14017, measuring 0.61m long, 0.45m wide and 0.28m deep with near-vertical sides and a flat base. A lower fill of mid brown grey silt (14018) was overlain by upper deposit of dark brown grey sandy silt (14019). No finds were recovered.
- 5.161. Near the centre of the trench, north-east/south-west aligned ditch 14004 measured 1.5m wide and 0.48m deep with steep sides and a concave base and was filled by a single fill, 14005, comprising mid brown silty sand. No finds were recovered.
- 5.162. In the south-east half of the trench, ditch terminus 14006 extended into the trench from the south-west limit of excavation, running on an east/west alignment and terminating within the trench. The feature measured 0.44m wide and 0.22m deep, with concave sides and a concave base and contained an undated fill of mid grey brown sandy clay (14007).

Trench 141 (Fig. 18)

- 5.163. Curvilinear ditch 14103 was exposed at the northern end of the trench, aligned broadly north-east/south-west. The feature measured 1.3m wide and 0.34m deep with moderately steep sides and a flat base and contained a single fill of light brown silty clay, 14104, which produced two fragments of Late Iron Age to Early Roman pottery.

Trench 142 (Fig. 71)

- 5.164. North-west/south-east aligned ditch 14204 matched part of a curvilinear anomaly identified by the geophysical survey. The ditch measured 1.7m wide and 0.35m deep with concave sides and a flat base and contained a single fill of mid brown silty sand, 14205. A small assemblage of industrial waste and one iron nail were recovered.

Trench 143 (Fig. 18)

- 5.165. A broadly east/west aligned possible furrow, 14303, was investigated in the trench, measuring 2.1m wide and 0.13m deep with gently sloped sides and a mostly flat base. The feature contained a single fill of light yellow brown sandy silt, 14304, which produced two sherds of pottery of uncertain date.

Trench 144 (Fig. 72)

- 5.166. Near the centre of the trench, a single pit 14403 was investigated, measuring 0.85m in diameter and 0.2m deep, with concave sides and a concave base. A lower fill of light brown silty sand, 14404, was overlain by an upper deposit of dark grey sandy silt, 14405, which produced two sherds of prehistoric pottery.

Trench 145 (Fig. 73-74)

- 5.167. North-west/south-east aligned ditch terminus 14503 extended into the trench from the eastern limit of excavation before terminating, and broadly matched the location of a geophysical anomaly forming part of a large segmented possible ring ditch. Ditch 14503 measured 0.51m wide and 0.23m deep, with steep sides and a flat base, and contained a single fill of mid brown grey sandy silt (14504). No finds were recovered.
- 5.168. Near the southern end of the trench, intercutting ditches 14505 and 14507 were aligned broadly east/west, matching part of the large curvilinear geophysical anomaly. Ditch 14505, the earlier of the two features, measured 3.05m wide and 0.43m deep, with moderately steep sides and a concave base, and contained a single fill of mid grey brown silty clay (14506) which produced six shards of post-medieval/modern bottle glass as well as nine pieces of electrical wire and one fragment of pottery.
- 5.169. The features' southern edge was truncated by later ditch 14507, measuring 2.09m wide and 0.29m deep with concave sides and a concave base. Ditch 14507 contained a single undated fill of mid orange brown silty clay (14508).

5.170. Immediately to the north of ditches 14505/14507, ditch 14509 crossed the trench on a north-west/south-east alignment, measuring 1.67m wide and 0.41m deep, with moderately steep sides and a concave base. The feature contained a lower fill of mid yellow brown silty sand, 14510, overlain by an upper deposit of mid brown silty clay, 14511, neither of which produced any dating evidence

Trench 146 (Fig. 18)

5.171. Ditch 14603 extended into the trench from the north-western limit of excavation, running south-east before terminating within the trench. The feature measured 0.6m wide and 0.35m deep with steep sides and a flat base and contained a single undated fill of mid yellow brown silty clay, 14604.

5.172. To the south, intercutting ditch 14609 and furrow 14611 crossed the trench running on a broadly east/west alignment. Ditch 14609 measured 1.36m wide and 0.46m deep with steep sides and a concave base, and contained a single fill 14610 of dark brown grey silty clay. The feature's southern edge truncated furrow 14611, measuring 0.44m wide and 0.13m deep, with gently sloped sides and a flat base. The furrow was filled by a single deposit 14612 of light yellow brown sandy silt. No finds were recovered.

5.173. Pit 14607 was located near the centre of the trench, to the south of features 14609/14611, and measured 0.54m in diameter and 0.11m deep, with steep sides and a concave base. A single fill, 14608, comprising dark brown grey silty clay contained no finds.

5.174. Further to the south, east/west aligned ditch 14605 measured 0.7m wide and 0.2m deep with steep sides and a concave base, and contained a single fill 14606 of mid grey brown silty clay. A single sherd of pottery of uncertain date was recovered.

5.175. Ditch 14613 crossed the south-western end of the trench on a north-west/south-east alignment, measuring 1.5m wide and 0.43m deep with gently sloped sides and a flat base. The feature contained a single fill (14614) of light yellow brown sandy silt which produced one iron nail and three sherds of Iron Age and medieval pottery.

Trench 147 (Fig. 18)

5.176. Near the eastern end of the trench, ditch 147 was investigated, running on a north-west/south-east alignment. The feature broadly matched the location of a linear

geophysical anomaly, although the alignment did not match entirely. Ditch 14703 measured 3.4m wide and greater than 0.6m deep with steep sides; the base was not reached due to safety concerns. A lower fill 14704 of mid brown silty sand produced four fragments of animal bone and the remains of a folding knife and was overlain by a middle deposit 14705 of light yellow brown sandy silt. This in turn was sealed by an upper fill of light brown silty sand (14706) which produced a single fragment of animal bone and an iron nail.

- 5.177. Immediately to the west, north-west/south-east aligned possible furrow 14707 measured 2.4m wide and 0.12m deep with gently sloped sides and a flat base. The feature contained a single fill of mid red brown silty sand, 14708, which produced no finds.

Trench 150 (Fig. 18)

- 5.178. Pit 15003 was revealed at the southern end of trench 150, measuring 0.35m in diameter and 0.22m deep with steep sides and a flat base. A single fill 15004 of mid yellow brown sandy silt produced no finds.

Trench 151 (Fig. 75)

- 5.179. Pit 15103 was only partially revealed within the trench, extending from the southern limit of excavation. The feature measured 0.5m wide and 0.08m deep with gently sloped sides and a flat base and contained a single fill 15104 of mid yellow brown sandy silt.

Trench 158 (Fig. 18)

- 5.180. Ditch 15802 crossed the trench on a north-east/south-west alignment, measuring 0.96m wide and 0.36m deep, with steep sides and a narrow concave base. The feature contained a lower fill 15803 of mid orange brown sandy silt, which was overlain by an upper deposit 15804 of dark brown grey silty clay. No finds were recovered.
- 5.181. Immediately to the east, pit 15805 measured 0.66m in diameter and 0.14m deep, with steep sides and a concave base. A single fill 15806 of dark brown grey silty clay produced a single fragment of animal bone and two sherds of Roman pottery.
- 5.182. A cluster of five north/south aligned intercutting ditches in the eastern half of the trench matched a linear geophysical anomaly forming part of a large potential

enclosure. The earliest feature, ditch 15807, measured 1.13m wide and in excess of 0.8m deep; the base was not reached due to safety concerns. A single fill 15808 of light yellow grey silty clay produced a small assemblage of animal bone and one sherd of Roman pottery. The feature was recut by later ditch 15809, measuring 0.86m wide and 0.6m deep with steep sides and a concave base, and filled by a single deposit 15810 of dark grey silty clay which produced 17 fragments of animal bone. Ditch 15809 in turn was recut by two separate ditches 15811 and 15815, measuring 0.44m wide and 0.38m deep and 0.79m wide and 0.44m deep respectively with matching profiles of steep sides and narrow, concave bases. Each ditch contained a single fill, comprising mid brown orange sandy silt (fill 15812 of ditch 15811) which produced eight fragments of animal bone and two sherds of Roman pottery; and light brown grey silty clay (fill 15816 of ditch 15815) which produced one sherd of prehistoric pottery. The final feature in the sequence was ditch 15813, truncating ditch 15811, measuring 0.4m wide and 0.21m deep with steep sides and a concave base. The ditch contained a single fill 15814 of light brown yellow silty clay which produced 12 fragments of animal bone and one sherd of prehistoric pottery which may be derived from an earlier feature within the sequence.

Trench 159 (Fig. 76)

- 5.183. Two parallel north-west/south-east aligned ditches, 15904 and 15909, were revealed in trench 159, matching two parallel linear anomalies. Ditch 15904, the easternmost feature, measured 1.6m wide and 0.72m deep with steep sides and a concave base, and contained a lower fill 15905 of light yellow brown silty clay which produced one fragment of animal bone and two sherds of pottery, overlain by a second deposit 15906 of dark grey black silty clay. This in turn was sealed by an upper fill 15907 of dark brown grey silty clay which produced a moderate assemblage of animal bone, one fragment of daub, and nine sherds of Late Iron Age to Early Roman pottery. Bulk samples recovered from fills in both features produced a variety of cereal grains and charred seeds, as well as charcoal and terrestrial snail shells.
- 5.184. The western edge of ditch 15904 truncated curvilinear ditch 15902, measuring 0.44m wide and 0.33m deep with steep sides and a concave base. The feature contained a single fill 15903 of mid brown red silty clay which produced no finds.
- 5.185. Ditch 15909, to the west, measured 1.3m wide and 0.7m deep with steep sides and a flat base, and contained a lower fill 15911 of light grey brown silty clay, overlain by

an upper deposit 15910 of dark grey brown silty clay. A total of 45 fragments of animal bone and 13 sherds of 3rd century or later pottery were recovered from the upper fill.

Trench 161 (Fig. 18)

- 5.186. A single east/west aligned ditch 16102 was revealed in the northern half of trench 161, measuring 1.13m wide and 0.38m deep with steep sides and a concave base. The feature contained a single fill 16103 of mid grey brown silty clay which produced, four sherds of Iron Age to Roman pottery and four fragments of post-medieval/modern tile, as well as some animal bone.

Trench 162 (Fig. 18)

- 5.187. North-west/south-east aligned ditch 16202 crossed the centre of the trench, matching a linear geophysical anomaly. The feature measured 1.03m wide and 0.46m deep with steep sides and a concave base, and contained a single fill 16203 of light grey brown silty clay. No finds were recovered.

Trench 164 (Fig. 18)

- 5.188. A single east/west aligned ditch 16402 was encountered in trench 164, matching the northernmost of two parallel linear geophysical anomalies. The ditch measured 0.9m wide and 0.53m deep with steep sides and a concave base, and was filled by a single deposit 16403 of mid orange brown silty clay which produced four fragments of post-medieval/modern tile.

Trench 167 (Fig. 18)

- 5.189. Ditch 16702 crossed the northern portion of trench 167 running on an east/west alignment, measuring 0.7m wide and 0.09m deep with gently sloped sides and a concave base. A single fill 16703 of mid grey brown silty clay contained no finds.

Trench 169 (Fig. 19)

- 5.190. Pit 16902 was investigated near the centre of the trench, measuring 0.4m in diameter and 0.12m deep, with steep sides and a flat base. A single fill 16903 of pale pink brown clayey silt produced six fragments of fired clay.
- 5.191. Further to the north, possible tree throw 16904 measured 0.8m in diameter and 0.1m deep with irregular sides and an irregular base. A single fill 16905 of dark brown silty clay produced no finds.

Trench 171 (Fig. 77-78)

- 5.192. A single north-east/south-west aligned ditch 17102 was encountered in trench 171, matching a broadly linear geophysical anomaly. The feature measured 1m wide and 0.19m deep with moderately sloped sides and a flat base, and was filled by a single deposit 17103 of dark brown grey silty clay. Eight sherds of Late Iron Age to Early Roman pottery were recovered.

Trench 176 (Fig. 19)

- 5.193. Ditch 17602 crossed the western end of the trench, running on a north-east/south-west alignment. The location of the feature matched that of a curvilinear geophysical anomaly, although the alignment did not match. The ditch measured 0.7m wide and 0.25m deep with steep sides and a slightly uneven base, and contained a single fill 17603 of light orange brown silty clay. No finds were recovered.

Trench 177 (Fig. 19)

- 5.194. Curvilinear ditch 17702 crossed the north-eastern end of the trench on a north-east/south-west alignment, matching a geophysical anomaly forming a large ring ditch. The feature measured 1.2m wide and 0.29m deep with steep sides and a flat base, and contained a single fill 17703 of dark orange brown silty clay. No finds were recovered.

Trench 179 (Fig. 20)

- 5.195. A single east/west aligned ditch, 17903, was revealed within the trench, matching part of an L-shaped geophysical anomaly. The feature measured 1.3m wide and 0.24m deep with gently sloped sides and an irregular base and contained a single fill 17904 comprising mid brown silt. No finds were recovered.

Trench 182 (Fig. 79)

- 5.196. North-west/south-east aligned ditch 18202 matched a sinuous geophysical anomaly, measuring 0.9m wide and 0.24m deep with steep sides; the base was not reached due to water ingress. The feature contained one fill 18203, comprising mid grey brown silty clay which produced no finds.

Trench 190 (Fig. 80)

- 5.197. An east/west aligned ditch, 19003, was encountered in the eastern half of trench 190, measuring 1.09m wide and 0.26m deep with steep sides and a flat base. The feature contained a single fill 19004 of dark brown grey silty clay which produced a single

fragment of Iron Age pottery. A small number of charred hazelnut shells and a single weed seed were also recovered during the processing of a bulk soil sample taken from the fill. Although the feature did not directly correspond with any geophysical anomaly, it was aligned parallel to a linear anomaly located approximately 4m to the north.

- 5.198. To the west, north/south aligned ditch 19005 matched a linear geophysical anomaly, measuring 0.7m wide and 0.41m deep with steep sides and a concave base. A single fill 19006 of dark grey brown silty clay contained no finds.
- 5.199. Ditch 19007, running on a north-east/south-west alignment, was located immediately to the west of ditch 19005, matching a linear geophysical anomaly. The feature measured 1.31m wide and 0.32m deep with steep sides; the base was not reached. A single fill 19008 of dark brown grey silty clay produced a single fragment of industrial waste. A minimal amount of charcoal was recovered from a bulk soil sample taken from the fill.

Trench 192 (Fig. 21)

- 5.200. A single north-west/south-east aligned ditch, 19203, was encountered in trench 192, matching an L-shaped geophysical anomaly. The ditch measured 0.6m wide and 0.29m deep with steep sides and a flat base and contained a single fill 19204 comprising mid red brown silty clay. No finds were recovered.

Trench 196 (Fig. 21)

- 5.201. North-west/south-east aligned ditch 19602 crossed the north-east end of the trench, measuring 0.8m wide and 0.4m deep with near-vertical sides and a flat base. The feature contained a single fill 19603 comprising dark orange brown clayey sand which produced no finds.
- 5.202. In the south-west portion of the trench, ditch 19604 was aligned north-west/south-east, broadly matching a linear geophysical anomaly. The feature measured 2.71m wide and 0.77m deep with near-vertical sides; the base was not reached. A single fill 19605 comprising mid red brown sandy clay produced three fragments of animal bone and one sherd of Iron Age pottery. A bulk soil sample taken from the fill produced only a small amount of charcoal.

Trench 197 (Fig. 81)

- 5.203. North-west/south-east aligned ditch 19703 crossed the southern end of trench 197, matching part of a circular curvilinear geophysical anomaly. The feature measured 1.37m wide and 0.38m deep with moderately steep sides and a flat base. A lower fill 19704 of mid grey brown silty clay was overlain by an upper deposit 19705 of dark grey brown silty clay. No finds were recovered, and the bulk soil sample produced only a minimal amount of charcoal.
- 5.204. Near the centre of the trench, a large possible feature was recorded in plan only, matching the return of the circular geophysical anomaly.

Trench 200 (Fig. 21)

- 5.205. A single north-east/south-west aligned ditch 20002 was investigated near the south-west end of trench 200, measuring 1.12m wide and 0.75m deep with steep sides and a flat base. A modern ceramic drain was observed within the base of the feature, and the single fill 20003, comprising dark brown grey clayey sand, produced a fragment of post-medieval/modern window glass as well as three fragments of modern pottery.
- 5.206. No feature was observed corresponding with the linear geophysical anomaly crossing the centre of the trench.

Trench 201 (Fig. 21)

- 5.207. East/west aligned ditch 20102, broadly matching a linear geophysical anomaly, extended into the trench from the eastern limit of excavation and terminated within the trench. The feature measured 0.42m wide and 0.22m deep with steep sides and a concave base, and contained a single fill 20103 of mid orange brown clayey sand. No finds were recovered.

Trench 203 (Fig. 21)

- 5.208. North-west/south-east aligned ditch 20302 crossed the centre of the trench, measuring 0.9m wide and 0.56m deep with steep sides and a concave base. A single fill 20303 of mid grey brown clayey sand produced no finds. The feature did not correspond with any geophysical anomaly.
- 5.209. At the northern end of the trench, north-west/south-east aligned ditch 20304 matched a linear geophysical anomaly, measuring 0.33m wide and 0.08m deep with gently

sloped sides and a concave base. The single fill 20305, comprising mid orange brown clayey sand, produced no finds.

- 5.210. A north-east/south-west aligned linear feature was also encountered near the southern end of the trench and recorded in plan only.

Trench 204 (Fig. 204)

- 5.211. Pit 20402 was only partially exposed within the trench, extending from the north-western limit of excavation. The feature measured 1.95m long, 0.6m wide and 0.57m deep with steep sides and a concave base, and contained a single fill 20403 of mid orange brown clayey sand. A total of eight sherds of Iron Age pottery were recovered, and a bulk soil sample taken from the fill produced minimal amounts of charred plant remains, charcoal and terrestrial snail shells.

- 5.212. Near the centre of the trench, north-west/south-east aligned ditch 20407 matched a linear geophysical anomaly, measuring 0.84m wide and 0.21m deep with moderately steep sides and a concave base. The feature contained a lower fill 20409 of mid orange brown sandy silt which produced three sherds of pottery, covered by an upper deposit 20408 of mid grey brown clayey silt. Three fragments of Iron Age pottery were recovered from fill 20409.

- 5.213. The north-east edge of ditch 20407 truncated pit 20404. The pit measured 1.48m long, 1.18m wide and 0.21m deep with irregular sides and an irregular base and contained two fills (20405 and 20406) of mid orange brown and mid grey brown clayey silt. A total of six animal bone fragments and 11 sherds of Iron Age pottery were recovered from fill 20405, along with minimal amounts of charred plant remains and snail shells recovered from a bulk soil sample.

Trench 209 (Fig. 83-84)

- 5.214. At the northern end of the trench, a shallow north-east/south-west aligned gully 20936 measured 0.2m wide and 0.2m deep with moderately steep sides and a slightly irregular base, and contained a single fill 20937 of mid grey brown silt which produced no finds. The feature was truncated by posthole or small pit 20938, measuring 0.4m wide and 0.2m deep, with steep sides and a flat base. The posthole contained a single fill 20939 of mid grey brown silt which produced two fragments of animal bone.

-
- 5.215. To the south, posthole 20934 measured 0.52m in diameter and 0.21m deep, with steep concave sides and an irregular base. The feature contained a single fill 20935 of mid grey brown silty clay which produced no finds.
- 5.216. Approximately 1.3m to the south, posthole 20903 measured 0.25m in diameter and 0.18m deep, with steep concave sides and a flat base, and contained a fill of dark grey sandy silt (20905), which contained a number of large limestone fragments possibly used as packing or a post-pad (20904). A total of six fragments of animal bone, one fragment of daub, and seven sherds of Late Iron Age to Early Roman pottery were recovered from fill 20905.
- 5.217. A north-east/south-west aligned cluster of partially intercutting pits and postholes was observed immediately to the south. Pit 20940 only extended partially into the trench from the eastern limit of excavation, measuring 0.8m wide and 0.3m deep, with steep sides and a concave base. The feature contained a possible post-pipe fill 20942 of dark brown silty clay, with an outer packing deposit 20941 of light brown silty clay. A mostly intact dog burial (20943) was recovered, along with a small number of burnt bones and one sherd of late-1st to 2nd century Roman pottery.
- 5.218. Immediately to the south-west, oval pit 20944 measured 1.46m long, 0.6m wide and 0.12m deep with concave sides and a concave base, and contained a lower fill 20945 of light brown silty clay which produced a single sherd of Roman pottery, overlain by an upper deposit 20946 of dark brown silty clay. Pit 20944 was seen to truncate posthole 20947, measuring 0.67m long, 0.6m wide and 0.35m deep with concave sides and a concave base. The feature contained a lower fill 20948 of light brown silty clay, covered by an upper deposit 20949 of dark brown silty clay which produced animal bone including four burnt examples, as well as fired clay and 29 sherds of mid-1st to 2nd century Roman pottery.
- 5.219. Immediately to the south, posthole 20908 measured 0.49m in diameter and 0.21m deep, with steep sides and an irregular base, and contained a single fill 20909 of dark grey brown silty clay which produced a fragment of Iron Age pottery.
- 5.220. Approximately 1.4m to the south, ditch 20922 crossed the trench running on a north-east/south-west alignment, measuring 0.7m wide and 0.42m deep with steep sides and a concave base. The feature contained a single fill 20923 of dark grey brown sandy silt which produced a moderate assemblage of animal bone including burnt

examples, fired clay, and a fragmentary possible iron knife blade. A small number of cereal grains as well as charred seeds and charcoal, alongside aquatic snail shells, were recovered from a bulk soil sample.

- 5.221. The southern edge of ditch 20922 was truncated by later posthole 20924, measuring 0.7m in diameter and 0.12m deep with gently sloped sides and a concave base. The feature was filled by a single deposit 20925 of light brown sandy silt which produced a very small assemblage of animal bone.
- 5.222. Immediately to the south, posthole 20932 measured 0.24m in diameter and 0.2m deep, with steep sides and a concave base. The feature contained a single fill 20933 of mid orange brown and light grey brown silty sand, with a number of limestone fragments. No finds were recovered.
- 5.223. North/south aligned ditch segment 20918/20926 was only partially exposed within the trench, running along the eastern limit of excavation. The visible extent of the feature measured around 0.2m wide and up to 0.12m deep, with steep sides and a concave base, and was filled by a single fill of mid to dark grey brown silty clay (20919/20927). One sherd of Iron Age pottery was recovered.
- 5.224. The southern end of ditch 20918/20926 was truncated by posthole 20928, extending into the trench from the eastern limit of excavation. The posthole measured 0.27m in diameter and 0.11m deep with moderately steep sides and a concave base, and contained a single fill 20929 of dark grey brown silty clay which produced no finds.
- 5.225. Immediately to the west of posthole 20928 was posthole 20930, measuring 0.49m in diameter and 0.2m deep, with moderately steep sides and a concave base. The feature contained a single fill 20931 of dark grey brown silty clay which produced one fragment of animal bone and one of ceramic building material.
- 5.226. Approximately 0.5m to the north-west was posthole 20906, measuring 0.7m in diameter and 0.13m deep, with steep sides and a concave base. The feature was filled by a single fill 20907 comprising mid grey brown silty clay with frequent limestone fragments. No finds were recovered.
- 5.227. The northern portion of ditch 20918 was truncated by a north-east/south-west aligned possible construction cut 20920 which extended into the trench from the eastern limit of excavation. The construction cut measured 0.4m wide and 0.18m deep, with steep

sides and a flat base, and was filled by a single deposit 20921 of mid grey brown silty clay.

5.228. A set of three postholes (20912, 20914, and 20916) were observed cutting the line of the construction cut, at intervals of approximately 0.1m. Posthole 20912, the westernmost feature, measured 0.4m in diameter and 0.18m deep, with steep sides and a concave base, and was filled by a single deposit 20913 of mid grey brown silty clay. A total of five animal bone fragment and three sherds of Late Iron Age pottery were recovered, and a bulk soil sample produced a small number of wheat grains a some charcoal as well as terrestrial snail shells. Immediately to the east, posthole 20914 was broadly identical to posthole 20912 in size and profile, and also contained a single fill, 20915, of mid grey brown silty clay, which one sherd of Iron Age to Roman pottery. The easternmost posthole, 20916, was only partially exposed within the trench, extending from the eastern limit of excavation, and measured 0.2m in diameter and 0.18m deep with steep sides and a concave base. The single fill 20917 of dark grey brown silty clay produced a small assemblage of animal bone.

5.229. In the southern half of trench 209, north-west/south-east aligned ditch 20910 matched a linear geophysical anomaly, measuring 1.64m wide and 0.4m deep with moderately steep sides and an irregular base. The feature contained a single fill 20911 comprising mid grey brown silty clay which produced 25 fragments of animal bone and 18 sherds of 3rd to 4th century Roman pottery.

6. THE FINDS BY ALISTAIR BARCLAY, ALEX BLISS, JACKY SOMMERVILLE, PETE BANKS, IAN ROWLANDSON AND H.G. FISKE, RUTH SHAFFREY AND DAVID DUNGWORTH WITH STEPHEN KNOWLES

6.1. The artefactual material was recorded from 155 deposits: the fills of ditches, ring ditches, pits, postholes and the topsoil and the subsoil (Appendix B). The material was recovered by hand and from eight bulk samples and recorded in accordance with the ClfA finds Toolkit (ClfA 2022).

Pottery

6.2. One thousand, two hundred and nine sherds (maximum 927 vessels, 15.520 kg, 9.14 RE) were recovered in total from fourteen trench groups.

6.3. The pottery presented ranged in date from earlier prehistoric to modern with most of the pottery dated to the Iron Age to Roman periods. Many of the trenches contained

only a few sherds; featureless shell-gritted sherds should be checked with a post-Roman pottery researcher where indicated to clarify the dates attributed to some of the groups.

- 6.4. Although the pottery from a number of trenches had limited research potential good groups of earlier Prehistoric pottery were recorded from trenches 40-45 and 114. Small quantities of Iron Age pottery were recorded including Middle to Late Iron Age Scored ware types from trenches 113 and 115. There were a large number of featureless shell-gritted body sherds recorded that may also have been of Iron Age date but many of these should be checked with a post-Roman pottery researcher to confirm this identification. A few trenches had good groups. Late Iron Age or transitional late Iron Age to early Roman groups were more numerous and included small groups from trenches 1-3, 162-171 and 139-157 with larger assemblages from 105-138, 158-161+209 and probably trenches 11-16. Although most of these groups were rather fragmentary a good group of sherds were recorded from the trench 158-161+209 area including a range of jars with rilled shoulders and necked bowls and jar/bowls with cordoned decoration similar to assemblages recorded from Late La Tène III type assemblages from Saltersford in Lincolnshire and Weekley, Northamptonshire (Knight 2002; Elsdon 1996a; Jackson and Dix 1987).
- 6.5. Mid to late Roman groups of pottery were recorded from trenches 105-138 and 162-171 that may be situated in the vicinity of rural Roman settlements. The range of pottery present was similar to other groups from this part of the East Midlands, with most of the pottery being from local production centres and the Nene Valley with a limited quantity of samian, mortaria and amphora also present.

Methodology

- 6.6. An archive has been produced to comply with the requirements of the Study Group for Roman Pottery (Darling 2004) and Standard for Pottery Analysis in Archaeology (Barclay et al., 2016) using the codes and system developed by the City of Lincoln Archaeological Unit (Darling and Precious 2014) and Knight for the Iron Age forms and terminology (1998; PCRG 1997), the Leicestershire Museum fabric codes (see Pollard 1994, 1999, Clark 1999), and prehistoric fabric codes from the excavations at Humberstone (Marsden 2011). A maximum vessel count and rim equivalents were recorded following Pollard (1990). In the absence of scientific analysis no distinction has been made between vessels with grog or mudstone inclusions (Firman and Leary

2001; Rowlandson 2015; Allen et al. 1987). It is likely that a proportion of the pottery recorded in the handmade 'Grog' group may also contain mudstone inclusions.

6.7. To accommodate the scheme straddling the Rutland and Lincolnshire border the pottery has primarily been recorded to the Leicestershire fabric and form series with additional codes from Leicestershire Iron Age sites (Marsden 2011). Post-Roman pottery, where clearly identified, has been noted to broad ware class following the Leicestershire fabric scheme. For the sites in Lincolnshire the pottery has been concorded by fabric to the Lincolnshire fabric codes following the Lincolnshire Handbook (Jennings ed. 2019) as it is understood that the pottery from Lincolnshire will be deposited at The Collection, Lincoln.

6.8. In the South Kesteven area of Lincolnshire and in Rutland, fossil shell-gritted ware is prevalent on Middle Bronze Age sites onwards (eg. Percival 2020), also Late Bronze Age to early Iron Age (Knight 2002), Middle to Late Iron Age and the Roman period (eg. Cooper 2000b&c; Rowlandson 2017; Rowlandson et al. 2020). Calcareous-gritted early Saxon fabrics have been recorded from sites such as Quarrington and Rutland Water (Young 1996; Blinkhorn 2000) with middle Saxon shell-gritted Maxey wares (Addyman et al. 1964; Young 1996) also being common in this area. A range of late Saxon to medieval wares produced locally or closer to Lincoln form a large component of local ceramic assemblages (Young 1996; Young and Vince 2005). The authors have an expertise with Iron Age and Roman pottery and have endeavoured to provide close dating for assemblages that are likely to be within that range. A number of contexts contained a range of featureless shell-gritted body sherds of ambiguous date (notably Trenches 1-4, 11-16, 63-67 and 139-157). These have been noted within the initial dating summary table. As already stated, in order to refine the date of these groups it is recommended that a specialist in the local post-Roman pottery from the area should be consulted with a view to refining the dating of a number of the key contexts either as the assessment stage or at analysis. Experience with long lived tempering traditions in Lincolnshire (Lane and Trimble 2010) and non-soluble rock-gritted assemblages from eastern Yorkshire has shown the merit of checking these assemblages with other period specialists to avoid confusion later in the project. The presence of other datable artefacts or, at a later stage, radiocarbon dates can help with this process. As such some of the groups of featureless body sherds should be considered to be tentatively dated at this stage and may be subject to change. A tabulated summary by context and a sherd archive are presented

below. Detailed context by context descriptions have been tabulated and provided in the archive along with a fully quantified record of the pottery. Ambiguous dates, particularly when only featureless shell-gritted body sherds were present, have been identified with a '?' spot date.

Trenches 1-4: Braceborough and Wilsthorpe parish, south of Carby Road, west-southwest of Braceborough village, Lincolnshire

6.9. Seven pre-Roman sherds (0.118 kg, 0.04 RE) were recovered from Trench 1. The decorated sherds from context 110 were possibly of Iron Age date although this identification was not certain. Little more can be said about this small group of shell-gritted sherds.

Trench Group 1-4 Fabric Summary

Fabric code	Fabric group	Fabric details	Sher	Sherd %	Weight (g)	Weight %	Total RE %
CG1A	Shell	Shell gritted, low quartz, LIA-Erom	6	85.71%	116	98.31%	4
S1	Shell	Moderate-very common shell or platey voids	1	14.29%	2	1.69%	0

Trench Group 1-4 Form Summary

For	Form Type	Form Description	Sher	Sherd %	Weight (g)	Weight %	Total RE %
3	Jar	Unclassified	1	14.29%	54	45.76%	0
3B	Jar	Bead rim, neckless	1	14.29%	11	9.32%	4
-	Unknown	Form uncertain	5	71.43%	53	44.92%	0

Trenches 5-10: Braceborough and Wilsthorpe parish, south of trench group 1-4, Lincolnshire

6.10. Forty two sherds (0.822 kg, 0.34 RE) were recovered. All were Roman apart from a single Prehistoric handmade sherd from Trench 5. The majority of the pottery came from ditch 803 and included Nene Valley type grey ware, a sherd from a colour-coated bowl, fine grey ware with comb-stabbed decoration (D01, D02), and shell-gritted sherds. The Roman pottery from this group included Nene Valley type grey wares and Bourne type shell-gritted sherds. The range of pottery was fairly typical of assemblages from this area dating to the 2nd to 3rd century AD.

Trench Group 5-10 Fabric Summary

Fabric code	Fabric group	Fabric details	Sherd	Sherd	Weight	Weight	Total
C2	Fine	Colour coated with 'white' fabrics	3	7.14%	59	7.18%	7
GW2	Grog	Fine grey ware	4	9.52%	74	9.00%	0
GW4	Reduced	Light firing types as 'Nene Valley grey ware'	18	42.86%	397	48.30%	12
CG1	Shell	Shell gritted, coarse frequent-abundant	6	14.29%	204	24.82%	0
CG1A	Shell	Shell gritted, low quartz, LIA-Erom	1	2.38%	7	0.85%	0
CG3A	Shell	Mod-freq shell, handmade, early	3	7.14%	37	4.50%	9
CG3B	Shell	Greetham type, wheel made	6	14.29%	43	5.23%	6
S1	Shell	Moderate-very common shell or platy voids	1	2.38%	1	0.12%	0

Trench Group 5-10 Form Summary

Form	Form Type	Form Description	Sherd	Sherd %	Weight (g)	Weight %	Total RE %
9	Beaker	Unclassified	2	4.76%	17	2.07%	0
9J.1	Beaker	Biconical, carinated	2	4.76%	57	6.93%	0
5	Bowl	Unclassified	1	2.38%	20	2.43%	0
5O	Bowl	Segmental/shallow as samian 18/31	1	2.38%	25	3.04%	7
6	Bowl/Dish	Unclassified	1	2.38%	14	1.70%	0
3	Jar	Unclassified	1	2.38%	82	9.98%	0
3L.1	Jar	Necked, squared off tip	4	9.52%	55	6.69%	12
3M	Jar	Necked, bead/rolled/everted tips	2	4.76%	21	2.55%	15
-	Unknown	Form uncertain	28	66.67%	531	64.60%	0

Trenches 11-16: Essendine parish, east of Essendine village, west-northwest of trench group 5-10, Rutland

- 6.11. Three hundred and fourteen sherds (maximum 281 vessels, 2.727 kg, 1.05 RE) were recovered. The groups came from a range of ditches, layers, pits and a floor surface with most of the larger groups coming from trench 15. Full context by context description is provided in the tabulated dating summary. It is recommended that these assemblages should be looked at by a post-Roman pottery researcher to check their date.
- 6.12. Layer 1200 contained a range of shell-gritted wares and necked jars likely to be of later Iron Age to perhaps early Roman date. Pit 1212 included another medium sized group of shell-gritted sherds along with a sherd with a pre-firing piercing (D03) that may either be of post-Roman date or a Roman cheese-press. A further oxidised quartz sand-gritted sherd was recovered from this context. This group was unusual for one of Late Iron Age to early Roman date and may include post-Roman material. Layer 1300 contained a modern Black Glazed Earthenware sherd. Ditch fills 1305 and 1308 probably dated to the Iron Age or Roman period. Floor layer 1311 included

a reduced ware jar fragment and a shell-gritted jar with a flat base suggesting that the group may have been of Roman date. Assemblages from pits 1502 and 1504 contained Roman pottery but also a range of ambiguous shell-gritted wares that ought to be checked by a post-Roman pottery specialist to ensure that material from a later, post-Roman date, was not also present. Ditch fill 1507 contained a more obviously Roman group of sherds including shell-gritted wares, grey ware, fine grey ware and a sherd of Nene Valley grey ware. This group of trenches produced a large proportion of shell-gritted sherds as might be expected for an assemblage of Late Iron Age to Roman date in this area but dating of a number of groups was uncertain.

Trench Group 11-16 Fabric Summary

Fabric code	Fabric group	Fabric details	Sherd	Sherd %	Weight (g)	Weight %	Total RE %
SAM	Samian	Undifferentiated	1	0.32%	1	0.04%	0
OW5	Oxidised	Medium sandy oxidised, may include unrecognised Medieval	6	1.91%	47	1.72%	0
WW	Oxidised	White wear unspecified	1	0.32%	1	0.04%	0
GW	Reduced	Misc grey ware	4	1.27%	22	0.81%	11
GW3	Reduced	Fine sandy grey ware	15	4.78%	103	3.78%	8
GW4	Reduced	Light firing types as 'Nene Valley grey ware'	5	1.59%	24	0.88%	0
GW5	Reduced	Medium sandy grey ware	3	0.96%	6	0.22%	0
SW1	Sandy wares	Quartz mod-frequent IA tradition ware	1	0.32%	2	0.07%	2
SW2	Sandy	Transitional fine sandy wares	1	0.32%	2	0.07%	0
CG	Shell gritted	Misc shell gritted	41	13.06%	334	12.25%	19
CG1	Shell	Shell gritted, coarse frequent-abundant	193	61.46%	1844	67.62%	57
CG1A	Shell	Shell gritted, low quartz, LIA-Erom	12	3.82%	109	4.00%	2
CG2	Shell	Shell gritted, sandier than CG1	28	8.92%	180	6.60%	6
EA	Post-Roman	Unclassified post-med earthenware	1	0.32%	28	1.03%	0
FCLAY	Fired clay	Misc fired clay	2	0.64%	24	0.88%	0

Trench Group 11-16 Form Summary

Form	Form Type	Form Description	Sherd	Sherd %	Weight	Weight %	Total
6	Bowl/Dish	Unclassified	1	0.32%	13	0.48%	8
3	Jar	Unclassified	15	4.78%	177	6.49%	19
3B	Jar	Bead rim, neckless	1	0.32%	2	0.07%	2
3G	Jar	Everted rim	2	0.64%	6	0.22%	8
3G.1	Jar	Everted rim	1	0.32%	23	0.84%	18
3L	Jar	Necked, squared off tip	3	0.96%	68	2.49%	17
3M	Jar	Necked, bead/rolled/everted tips	3	0.96%	105	3.85%	13
11F	Misc	Cheese press?	1	0.32%	38	1.39%	7
-	Unknown	Form uncertain	287	91.40%	2295	84.16%	13

Trenches 23-27: Essendine parish, southeast of Essendine village, north of railway line, Rutland

- 6.13. Two sherds (37g, 0 RE) were recovered from Trench 23, these were of either Prehistoric or post-Roman date. Little more can be said about this small assemblage.

Trench Group 23-27 Fabric Summary							
Fabric code	Fabric group	Fabric details	Sherd	Sherd %	Weight (g)	Weight %	Total RE %
CG1	Shell	Shell gritted, coarse frequent-abundant	2	100.00%	37	100.00%	0

Trench Group 23-27 Form Summary							
Form	Form Type	Form Description	Sherd	Sherd %	Weight (g)	Weight %	Total RE %
-	Unknown	Form uncertain	2	100.00%	37	100.00%	0

Trenches 28-32: Essendine parish, southeast of trench group 23-27, north of railway line, Rutland

- 6.14. Four handmade sherds (50g, 0 RE) were recovered from Trench 30, these were of either Iron Age or post-Roman date. This group should be checked by a post-Roman pottery specialist.

Trench Group 28-32 Fabric Summary

Fabric code	Fabric group	Fabric details	Sherd	Sherd %	Weight (g)	Weight %	Total RE %
SW3	Sandy wares	Coarse sandy Belgic type LIA/Erom	1	25.00%	6	12.00%	0
CG1	Shell	Shell gritted, coarse frequent-abundant	3	75.00%	44	88.00%	0

Trench Group 28-32 Form Summary

Form	Form Type	Form Description	Sherd	Sherd %	Weight (g)	Weight %	Total RE %
-	Unknown	Form uncertain	4	100.00%	50	100.00%	0

Trenches 40-45: Essendine parish, southeast of trench group 28-32, north of railway line, Rutland

- 6.15. Seventy one handmade sherds (0.474 kg, 0.21 RE) were recovered; almost all were of Prehistoric date. Most notable were a group of impressed and incised decorated wares from pit 4408 likely to be of transitional Early/Middle Neolithic date (c. 3500–3300 cal BC). These include two decorated out-turned rims from Ebbsfleet Style bowls and a small number of impressed decorated body sherds. A group of pottery from pit 4007, fill 4008, also appeared to be of prehistoric date with a single rim fragment present in a grog-gritted fabric possibly suggesting a date in the earlier part of the 1st millennium BC. Other smaller groups included a range of fabrics with voids and clay pellets, grog with clay-pellets, or fossil shell. Fossil shell-gritted wares were

common from the middle Bronze Age onwards; many of the earlier fabrics from this region typically had voids and grog and clay pellet gritting similar to the incised ware sherds from context 4408 (Percival 2020; Allen et al. 1987; Rowlandson 2019).

Trench Group 40-45 Fabric Summary

Fabric code	Fabric group	Fabric details	Sherd	Sherd %	Weight (g)	Weight %	Total RE %
CG2	Shell	Shell gritted, sandier than CG1	3	4.23%	36	7.59%	0
IV	Voids	Handmade indeterminate voids	5	7.04%	3	0.63%	0
IVCP	Voids & clay pellets	Handmade indeterminate voids with clay pellets	11	15.49%	43	9.07%	4
S1	Shell	Moderate-very common shell or platey voids	33	46.48%	118	24.89%	6
S2	Shell	As S1 with common-very common quartz sand	6	8.45%	33	6.96%	0
G1	Grog	Shelly & sandy fabric with sparse rounded grog	13	18.31%	241	50.84%	11

Trench Group 40-45 Form Summary

For	Form Type	Form Description	Sher	Sherd %	Weight (g)	Weight %	Total RE %
3	Jar	Unclassified	3	4.23%	23	4.85%	15
-	Unknown	Form uncertain	68	95.77%	451	95.15%	6

Trenches 46-55: Ryhall parish, north of road 'The Drift', east of Pickworth village, Rutland

- 6.16. Two sherds (8g, 0 RE) of medieval and modern date were recovered. These sherds could be more closely identified by a post Roman pottery researcher although they had limited research potential.

Trench Group 46-55 Fabric Summary

Fabric code	Fabric group	Fabric details	Sherd	Sherd %	Weight (g)	Weight %	Total RE %
MS	Medieval misc	Medieval unspecified	1	50.00%	1	12.50%	0
MSW	Post-Roman	Modern unclassified stoneware	1	50.00%	7	87.50%	0

Trench Group 46-55 Form Summary

Form	Form Type	Form Description	Sherd	Sherd %	Weight (g)	Weight %	Total RE %
-	Unknown	Form uncertain	2	100.00%	8	100.00%	0

Trenches 63-67: Carlby parish, northwest of crossroads on B1176 Stamford Road at Vale Farm, Lincolnshire

- 6.17. Fourteen sherds (0.116 kg, 0 RE) were recovered from Trench 63, all from pit 6303, they were of Prehistoric or post-Roman date. These small featureless sherds were difficult to date and should be checked by a post-Roman pottery specialist.

Trench Group 63-67 Fabric Summary

Fabric code	Fabric group	Fabric details	Sherd	Sherd %	Weight (g)	Weight %	Total RE %
CG1A	Shell	Shell gritted, low quartz, LIA-Erom	7	50.00%	18	15.52%	0
CG2A	Shell	Shell gritted with sand, hand made	5	35.71%	75	64.66%	0
Q1	Quartz	Quartz sand common-abundant	2	14.29%	23	19.83%	0

Trench Group 63-67 Form Summary

For	Form Type	Form Description	Sher	Sherd %	Weight (g)	Weight %	Total RE %
3	Jar	Unclassified	5	35.71%	75	64.66%	0
-	Unknown	Form uncertain	9	64.29%	41	35.34%	0

Trenches 97-104: Essendine parish, south of Essendine village and railway line, northeast of Ryhall village, Rutland

- 6.18. Two sherds (14g, 0.02 RE) were recovered. These were a shell-gritted sherd from context 10203 probably of Early Prehistoric date and an oxidised sherd from context 10303 of Roman or Medieval date. Little more could be said about this small assemblage.

Trench Group 97-104 Fabric Summary

Fabric code	Fabric group	Fabric details	Sherd	Sherd %	Weight	Weight	Total
OW5	Oxidised	Medium sandy oxidised, may include unrecognised Medieval	1	50.00%	10	71.43%	2
S1	Shell	Moderate-very common shell or platy voids	1	50.00%	4	28.57%	0

Trench Group 97-104 Form Summary

For	Form Type	Form Description	Sher	Sherd %	Weight (g)	Weight %	Total RE %
3	Jar	Unclassified	1	50.00%	10	71.43%	2
-	Unknown	Form uncertain	1	50.00%	4	28.57%	0

Trenches 105-138: Essendine parish, south of Essendine village and railway line, east of Ryhall village, Rutland

- 6.19. Four hundred and sixty-nine sherds (5.619 kg, 4.66 RE) were recovered, these were mostly of Roman date but there were also smaller quantities of Prehistoric and Iron Age sherds. Many of the groups contained only a handful of sherds and these groups have been described in detail in the dating summary and full archive. The range of pottery seen in fresher groups suggest settlement in the area in the Middle Iron Age, Late Iron Age to early Roman period and the 3rd to 4th centuries AD.
- 6.20. Two sherds (body and base angle) with incised decoration and a fossil shell-gritted fabric were recorded from pit 11421, fill 11422. These sherds should be considered along with the Neolithic pottery noted above and as part of any final report. These sherds could belong to either the Middle Neolithic Peterborough Ware style (3400–2900 cal BC) or the Late Neolithic Grooved Ware style (3000–2400 cal BC) as the incised decoration and banded motifs are common to both.
- 6.21. Small groups including shell-gritted Scored ware from ditch 11324 (fill 11325) and ditch 11505 (fill 11507) suggested some Middle to Late Iron Age activity on the site. Good groups of Late Iron Age pottery were recorded from ditch 11803, fill 11805 which included two shell-gritted jars (D04-5) and a necked jar in a transitional sandy ware (D06) that would be worthy of illustration to illustrate the vessels in use on the site. Further sherds from this jar were also retrieved from ditch 11806 (fill 11808) which also contained pottery dating to the Late Iron Age.
- 6.22. This area had the greatest number of groups dating to the 3rd to 4th centuries AD. The range of material was typical of contemporary groups from the Rutland Water project and from Baston, Northamptonshire (Cooper 2000c; Darling et al. 2020). Dressel 20 amphorae, samian, Black Burnished ware 1 and Nene Valley type mortaria were all present but only in small quantities. Nene Valley grey ware types were well represented along with sandy grey wares. Shell-gritted types consisted of necked jars with under-cut squared off rims similar to those produced in the South Midlands tradition and it was noted that the fabrics also contained the punctate brachiopod type shells found in the products of that industry. Nene Valley type colour-coated wares were well represented although numbers of beakers were low and larger, more utilitarian types were more common as would be expected amongst an assemblage with a bias towards the later 3rd to 4th centuries AD.

Trench Group 105-138 Fabric Summary

Fabric code	Fabric group	Fabric details	Sherd	Sherd %	Weight (g)	Weight %	Total RE %
SAM	Samian	Undifferentiated	1	0.21%	2	0.04%	0
SAMCG	Samian	Central Gaulish	5	1.07%	48	0.85%	4
AM9A	Amphora	Dressel 20 - BAT AM1	1	0.21%	23	0.41%	0
MO	Mortaria	Unknown source	1	0.21%	8	0.14%	0
MO6	Mortaria	Nene valley fabric with slag trits	2	0.43%	39	0.69%	0
C11	Fine	Dark oxidised, dark reduced slip	1	0.21%	6	0.11%	0
C2	Fine	Colour coated with 'white' fabrics	88	18.76%	1123	19.99%	116
C3	Fine	Colour coated with a light oxidised core	17	3.62%	140	2.49%	16
C7	Fine	Dark oxidised fine sandy fabric, reduced slip	1	0.21%	1	0.02%	0
OW5	Oxidised	Medium sandy oxidised, may include unrecognised Medieval	1	0.21%	4	0.07%	0
BB1	Reduced	Black burnished 1, unspecified	5	1.07%	46	0.82%	7
GW	Reduced	Misc grey ware	1	0.21%	7	0.12%	4
GW3	Reduced	Fine sandy grey ware	9	1.92%	83	1.48%	7
GW4	Reduced	Light firing types as 'Nene Valley grey ware'	70	14.93%	1212	21.57%	104
GW5	Reduced	Medium sandy grey ware	5	1.07%	142	2.53%	30
SW2	Sandy	Transitional fine sandy wares	3	0.64%	30	0.53%	0
SW3	Sandy wares	Coarse sandy Belgic type LIA/Erom	1	0.21%	26	0.46%	9
CG1	Shell	Shell gritted, coarse frequent-abundant	19	4.05%	216	3.84%	11
CG1A	Shell	Shell gritted, low quartz, LIA-Erom	123	26.23%	1039	18.49%	42
CG1B	Shell	Shell gritted, low quartz, Late Rom	37	7.89%	416	7.40%	80
CG2B	Shell	As CG2A but wheel made (late?)	1	0.21%	5	0.09%	3
IV	Voids	Handmade indeterminate voids	2	0.43%	2	0.04%	0
IVCP	Voids & clay pellets	Handmade indeterminate voids with clay pellets	1	0.21%	2	0.04%	0
S1	Shell	Moderate-very common shell or platey voids	69	14.71%	830	14.77%	33
GT1	Grog	Coarse- 'Belgic' influence	1	0.21%	73	1.30%	0
GT3A	Grog	Coarse- mid-late Roman pink	2	0.43%	66	1.17%	0

MSW	Post-Roman	Modern unclassified stoneware	1	0.21%	23	0.41%	0
FCLAY	Fired clay	Misc fired clay	1	0.21%	7	0.12%	0

Trench Group 105-138 Form Summary

Form	Form Type	Form Description	Sherd	Sherd %	Weight (g)	Weight %	Total RE %
A	Amphora	Unclassified form	1	0.21%	23	0.41%	0
9	Beaker	Unclassified	7	1.49%	23	0.41%	0
9E.2	Beaker	Beaded rim	1	0.21%	4	0.07%	9
9F.1	Beaker	Plain rim	1	0.21%	4	0.07%	11
9J	Beaker	Biconical, carinated	1	0.21%	18	0.32%	0
5C.2	Bowl	Vestigial neck	1	0.21%	118	2.10%	7
5L	Bowl	Hemispherical or segmental with flange	1	0.21%	48	0.85%	0
B	Bowl	Unclassified form	1	0.21%	4	0.07%	4
6	Bowl/Dish	Unclassified	8	1.71%	173	3.08%	0
4B	Bowl/Jar	Necked/beaded, rolled, everted	17	3.62%	253	4.50%	32
4B.2	Bowl/Jar	Necked/beaded, rolled, everted	1	0.21%	20	0.36%	4
31	Dish	Samian form- see Webster 1996	3	0.64%	42	0.75%	0
6A	Dish	Plain rimmed	3	0.64%	35	0.62%	17
6A.1	Dish	Plain rimmed	1	0.21%	17	0.30%	3
6D	Dish	Stubby/flanged rim	4	0.85%	53	0.94%	25
6D.1	Dish	Stubby/flanged rim	1	0.21%	11	0.20%	4
6E.1	Dish	Groove-rimmed	2	0.43%	22	0.39%	7
6E.2	Dish	Groove-rimmed	5	1.07%	216	3.84%	28
1D.1	Flagons & Jugs	Flanged neck	1	0.21%	28	0.50%	0
3	Jar	Unclassified	64	13.65%	1658	29.51%	79
3A	Jar	Plain rim, neckless	1	0.21%	7	0.12%	4
3B.1	Jar	Bead rim, neckless	2	0.43%	24	0.43%	8
3B.2	Jar	Bead rim, neckless	3	0.64%	147	2.62%	13
3D.2	Jar	Ledge rim	1	0.21%	19	0.34%	2
3L	Jar	Necked, squared off tip	4	0.85%	77	1.37%	34
3L.2	Jar	Necked, squared off tip	2	0.43%	19	0.34%	12
3M	Jar	Necked, bead/rolled/everted tips	9	1.92%	95	1.69%	61
3M.2	Jar	Necked, bead/rolled/everted tips	13	2.77%	183	3.26%	44
4	Jar/bowl	Unclassified	7	1.49%	127	2.26%	47
M	Mortaria	Unclassified	3	0.64%	47	0.84%	0
7	Platter	Unclassified	1	0.21%	5	0.09%	0
7C.1	Platter	Flaring or flanged rim	2	0.43%	28	0.50%	7
-	Unknown	Form uncertain	297	63.33%	2071	36.86%	4

Trenches 139-157: Greatford parish, south of road from Belmesthorpe to Greatford, southwest of Greatford level crossing, Lincolnshire

- 6.23. Eleven sherds (79g, 0.09 RE) of largely mixed and uncertain date were recovered. All of the groups were small and mostly from ditches, a pit and a plough furrow. Shell-gritted sherds from ditch fill 14104 included a necked jar of Late Iron Age to early Roman date. A shell-gritted sherd of uncertain date was recovered from ditch fill 14606. Medieval wares were recovered from ditch fill 14614 and the remaining groups contained small fragments of Prehistoric pottery. Little could be said about these small groups.

Trench Group 139-157 Fabric Summary

Fabric code	Fabric group	Fabric details	Sherd	Sherd %	Weight (g)	Weight %	Total RE %
CG1A	Shell	Shell gritted, low quartz, LIA-Erom	2	18.18%	18	22.78%	7
CG3B	Shell	Greetham type, wheel made?	1	9.09%	5	6.33%	0
IVCP	Voids & clay pellets	Handmade indeterminate voids with clay pellets	3	27.27%	21	26.58%	0
G1	Grog	Shelly & sandy fabric with sparse rounded grog	1	9.09%	19	24.05%	2
MS	Medieval misc	Medieval unspecified	4	36.36%	16	20.25%	0

Trench Group 139-157 Form Summary

Form	Form Type	Form Description	Sherd	Sherd %	Weight (g)	Weight %	Total RE %
3	Jar	Unclassified	1	9.09%	19	24.05%	2
3M	Jar	Necked, bead/rolled/everted tips	1	9.09%	16	20.25%	7
-	Unknown	Form uncertain	9	81.82%	44	55.70%	0

Trenches 158-161, also 209: Uffington parish, southwest of trench group 139-157, Lincolnshire

- 6.24. Two hundred and twenty-five sherds (4.821 kg, 2.67 RE) were recovered, of Prehistoric through to Modern date. Most of the groups were small consisting of a few shell-gritted sherds (see tabulated data) although there were a few larger assemblages worthy of note.
- 6.25. Ditch 20922, fill 20923, contained the best group of Late Iron Age pottery including shell-gritted jars with everted rims (D08, D09), one with a rilled shoulder, and a necked jar. Also present were sherds from a grog-gritted necked bowl with cordon

decoration and a transitional sandy ware necked jar/bowl also with cordon decoration. A further grog-gritted carinated bowl with cordon decoration was also recovered from post hole 20912, fill 20913. Small groups of Late Iron Age to early Roman date were also recorded from ditch 15904, fill 15907 and post hole 20903, fill 20905 which consisted of similar ranges of pottery. A small group of early Roman pottery was recorded from post hole 20940, fill 20942 including a range of Iron Age tradition shell-gritted wares and sherds from a grey ware necked jar/bowl. A further group, probably dated to the early Roman period, was retrieved from post hole 20947 and dated on the presence of a shell-gritted jar with a rilled shoulder (D10).

6.26. Three noteworthy groups of Roman pottery dating to the 3rd to 4th century AD were recorded from ditch 15909 (fill 15910), layer 2900 and ditch 20910 (fill 20911). Shell-gritted ware jars were still common with examples of Bourne types and developed wheel made shell-gritted wares similar to the South Midlands tradition with punctate brachiopod shell inclusions being noted. Nene Valley grey wares and sandy grey wares were present but it was noticeable that there was a far higher proportion of Nene Valley type colour-coated wares, particularly larger vessels such as bowls, dishes and jars. This pattern of ceramic usage is similar to the Late Roman groups from Baston and the Rutland Water project (Darling et al. 2020; Cooper 2000c) where larger more utilitarian vessels were common in Nene Valley type colour-coated wares while beakers were rare.

6.27. The association of the Late Iron Age to early Roman pottery with post hole features suggests that structures on the site may have been constructed in the 1st century AD. The groups dating to the 3rd to 4th centuries AD shows activity continued in this area into the late Roman period. The range of forms and fabrics present from this group appears similar to those noted from elsewhere in Rutland and south-western Lincolnshire on basic rural sites, with a large proportion of shell-gritted wares in use along with smaller quantities of grey ware, colour-coated ware, and mortaria (eg. Cooper 2000c; Cooper 2004).

Trench Group 158-169 +209 Fabric Summary

Fabric code	Fabric group	Fabric details	Sher	Sherd %	Weight (g)	Weight %	Total RE %
SAM	Samian	Undifferentiated	1	0.44%	2	0.04%	0
MO6	Mortaria	Nene valley fabric with slag trits	1	0.44%	26	0.54%	0

C2	Fine	Colour coated with 'white' fabrics	7	3.11%	206	4.27%	26
C3	Fine	Colour coated with a light oxidised core	2	0.89%	43	0.89%	18
WW2	Oxidised	Fine white pipeclay fabric	1	0.44%	4	0.08%	0
WW4	Oxidised	Medium sandy	1	0.44%	3	0.06%	0
GW4	Reduced	Light firing types as 'Nene Valley grey ware'	9	4.00%	123	2.55%	0
GW5	Reduced	Medium sandy grey ware	33	14.67%	558	11.57%	0
GW6	Reduced	Moderately coarse wheel made grey ware	1	0.44%	3	0.06%	0
SW2	Sandy	Transitional fine sandy wares	8	3.56%	57	1.18%	0
CG	Shell gritted	Misc shell gritted	1	0.44%	6	0.12%	0
CG1	Shell	Shell gritted, coarse frequent-abundant	1	0.44%	28	0.58%	0
CG1A	Shell	Shell gritted, low quartz, LIA-Erom	140	62.22%	3124	64.80%	186
CG1B	Shell	Shell gritted, low quartz, Late Rom	2	0.89%	280	5.81%	0
CG2A	Shell	Shell gritted with sand, hand made	4	1.78%	85	1.76%	4
CG3B	Shell	Greetham type, wheel made	4	1.78%	39	0.81%	0
GT1	Grog	Coarse-'Belgic' influence	1	0.44%	23	0.48%	4
GT2	Grog	Fine grog gritted 'Belgic' type	8	3.56%	211	4.38%	29

Trench Group 158-169 +209 Form Summary

For	Form Type	Form Description	Sher	Sherd %	Weight (g)	Weight %	Total RE %
9	Beaker	Unclassified	1	0.44%	2	0.04%	0
9D	Beaker	Globular & bag-shaped	2	0.89%	32	0.66%	0
5D.2	Bowl	Low carination	7	3.11%	207	4.29%	27
4A	Bowl/Jar	Everted/recurved	3	1.33%	59	1.22%	0
6D	Dish	Stubby/flanged rim	2	0.89%	124	2.57%	26
6E.2	Dish	Groove-rimmed	1	0.44%	26	0.54%	18
3	Jar	Unclassified	55	24.44%	1642	34.06%	4
3A	Jar	Plain rim, neckless	1	0.44%	25	0.52%	5
3B	Jar	Bead rim, neckless	30	13.33%	825	17.11%	136

3F	Jar	Angular/everted rim	1	0.44%	14	0.29%	12
3G	Jar	Everted rim	1	0.44%	13	0.27%	8
3M	Jar	Necked, bead/rolled/everted tips	6	2.67%	61	1.27%	25
4	Jar/bowl	Unclassified	4	1.78%	37	0.77%	4
M	Mortaria	Unclassified	1	0.44%	26	0.54%	0

Trenches 162-171: Uffington parish, south of road from Belmesthorpe to Greatford, west-southwest of trench group 139-157, east of minor road from Uffington to Essendine, Lincolnshire

- 6.28. Eight sherds (0.127 kg, 0.04 RE) were recovered from Trench 171, they were of Late Iron Age to early Roman date. All of the sherds were recovered from ditch 17102, fill 17103 and included shell-gritted sherds and the base from a platter in an oxidised sand-gritted fabric. This material was fairly fresh and may suggest some activity on the site in the 1st century AD. Little more could be said about this small assemblage; the basal fragment from the platter was not suitable for illustration.

Trench Group 162-171 Fabric Summary

Fabric code	Fabric group	Fabric details	Sherd	Sherd %	Weight (g)	Weight %	Total RE %
SW2	Sandy	Transitional fine sandy wares	1	12.50%	21	16.54%	0
CG1A	Shell	Shell gritted, low quartz, LIA-Erom	7	87.50%	106	83.46%	4

Trench Group 162-171 Form Summary

Form Type	Form Description	Sherd	Sherd %	Weight (g)	Weight %	Total RE %
Jar	Unclassified	1	12.50%	6	4.72%	4
Platter	Unclassified	1	12.50%	21	16.54%	0
Unknown	Form uncertain	6	75.00%	100	78.74%	0

Trenches 190-208: Uffington parish, east of Newstead Lane, southwest of Wood Farm, in Lincolnshire

- 6.29. Thirty-eight sherds (0.508 kg, 0.02 RE) were recovered from seven contexts. Prehistoric pottery was recorded from contexts 14010, 14405 and 15106. A group that could be dated to the later Iron Age to early Roman period including a necked jar was recorded from context 14104, and two contexts contained medieval or post-medieval glazed wares (14304 and 14614). The assemblage from these trenches has little archaeological research potential.

Trench Group 190-208 Fabric Summary

Fabric code	Fabric group	Fabric details	Sherd	Sherd %	Weight (g)	Weight %	Total RE %
CG1A	Shell	Shell gritted, low quartz, LIA-ERom	35	92.11%	396	77.95%	2
EA	Post-Roman	Unclassified post-med stoneware or earthenware	2	5.26%	2	0.39%	0
MSW	Post-Roman	Modern unclassified stoneware	1	2.63%	110	21.65%	0

Trench Group 190-208 Form Summary

For	Form Type	Form Description	Sher	Sherd %	Weight (g)	Weight %	Total RE %
3	Jar	Unclassified	5	13.16%	32	6.30%	2
-	Unknown	Form uncertain	33	86.84%	476	93.70%	0

Research Potential

Earlier Prehistoric

- 6.30. A small range of earlier Prehistoric pottery was present from the scheme. The most notable groups were recovered from trenches 40-45 where incised wares were recognised. This material should be studied in closer detail as part of any final report with a view to providing more detailed comparisons for the vessels recorded here (cf Knight et al. 2012, Research Objective 3J). It is possible that further, more significant assemblages might be identified in material from elsewhere in the scheme.

Iron Age

- 6.31. The small range of Iron Age pottery from this scheme has a limited potential for addressing the East Midlands Research Agenda themes about typological analysis (cf Knight et al. 2012, Research Objective 4B). Most of the groups were small and fragmentary with few forms suitable for illustration. There was no material suitable for the use of radiocarbon dating to address any of the chronological issues about pottery in the region, in the way that has recently been undertaken for local groups from Stamford Down (Daniel 2016; Rowlandson 2017). If further investigations were undertaken it is possible that more significant assemblages might be unearthed but at present the pottery from these trenches has limited potential for further study.

Roman

- 6.32. The range of Roman pottery present was similar to what might be expected from a basic rural assemblage from the Rutland/Lincolnshire border (Cooper 2000c). Few of the assemblages were large but some would provide dating for the features investigated. The better groups were recovered from trenches 105-138 in Essendine

parish, and 158-161 in Uffington. The vast majority of wares present were locally produced, with few mortaria, amphora or imported fine ware sherds. The assemblages were similar in composition to those recorded from the rural sites from the Rutland Water scheme and Baston (Cooper 2000c; Darling et al. 2020) rather than those from secondary urban centres such as Navenby and Saltersford (Rowlandson 2011; Rowlandson and Fiske 2022). A small number of vessels could be illustrated to show the key vessels from this assemblage but this assemblage has limited potential to advance the key local research agenda (Knight et al. 2012 objectives 5B and 5H).

- 6.33. If further excavations were to be undertaken in the vicinity of some of the more productive trenches (105-138 and 158-161) then more substantial and statistically viable assemblages might be recovered.

Post-Roman and modern

- 6.34. A small proportion of the assemblage was of post-Roman date. Although there was some ambiguity about the dating of some of the assemblages none of these groups contained significant numbers of feature sherds and it would appear unlikely that these assemblages, if proven to be post-Roman in date, would have any great significance.

Recommendations

- 6.35. It is recommended that the pottery from these trenches should be integrated with pottery from subsequent investigations in the event of further excavations being carried out as part of this project. In the event of the project moving to analysis:
- The shell-gritted wares should be shown to a relevant local post-Roman pottery specialist to check the preliminary dating offered in this assessment.
 - The earlier prehistoric pottery assemblage was small but a number of the diagnostic sherds would benefit from specialist consideration to offer a closer date, particularly those from trenches 40-46 with incised decoration (INC in Decoration column in the archive).
 - Post-Roman and modern wares once isolated from this assessment should be identified and recorded fully to the local fabric scheme.
 - Nine Iron Age or Roman vessels would be suitable for line illustration with a further one perhaps best recorded with a photograph (D01-D10 in archive).

These vessels have been selected to represent unusual types or vessels from good groups that potentially assist dating of the sites.

- At present a number of the assemblages are very small and have limited research potential. In the event of analysis the larger more diagnostic groups should form the main focus of the Iron Age and Roman pottery report.

Ceramic Building Material (CBM)

6.36. A total of 25 fragments (4464g) of ceramic building material (CBM) were recorded from 16 deposits. The assemblage is made in oxidised shelly (sh) or fine (fs) and medium sandy fabrics (ms), some with clay pellet (cp), calcareous (c), ferrous (fe) or shelly (sh) inclusions. A fragment of tegula (flanged roof tile) was recovered from ditch 11210 and a large fragment of imbrex (curved roof tile), was recovered from layer 11607. Both can be broadly dated to the Roman period. A further eight fragments of miscellaneous tile, most ranging between 33mm and 45mm in thickness, are also considered, based on their fabric, thickness and characteristics of firing, to date to the Roman period. Three fragments of tile or curved tile are most likely of post-medieval or modern date. Three undiagnostic fragments of CBM could not be assigned a form or date to their small size.

Fired clay

6.37. A total of 74 fragments (779g) of fired clay were recovered from 20 deposits. They are made in oxidised fine (fs) and medium sandy fabrics (ms), some with clay pellet (cp), calcareous (c), ferrous (fe), micaceous (m) or shelly inclusions (sh). The majority of fragments preserve no features suggestive of function. Eight fragments exhibited smoothed or flat surfaces. Six fragments, from pit 1502, ditch 15904 and postholes 20903 and 20940, contained rod-like impressions and probably represent fragments of burnt daub. Ditch 3004 produced fragments of a square sectioned object tapering towards one end. The object is likely a kiln bar of the type used to support pottery during the firing process. It dates to the Roman period and hints at pottery production taking place in the area. Similar tapering clay bars are known from the Roman kiln site at Market Overton, Rutland, approximately 20km to the west (Swan 2023).

Lithics

6.38. A total of 10 worked flints (33.7g) was hand-recovered from five deposits (all ditch fills). All are fine-grained and cortex is present on four items – it is chalky on two and abraded on two. This suggests that both primary (chalk) and secondary (e.g. river

gravel) sources were exploited. The nearest chalk bedrock, of the Grey Chalk Subgroup, is located approximately 61km to the east (BGS 2023). The artefacts were recorded according to broad debitage/artefact type as defined by Butler (2005). This small assemblage is composed of flakes, blades, a bladelet and a microdenticulate. The flakes are not chronologically diagnostic, but the blades (from fill 2314 of ditch 2313 and fill 4226 of ditch 4220) and bladelet (from fill 4207 of ring ditch 4203) are most likely to be of Mesolithic or Early Neolithic date. The microdenticulate (Ra. 1), also from ditch fill 4226, is a proximal fragment which was made on a blade blank. Both lateral dorsal edges feature very fine serrations which are quite heavily worn. Microdenticulates are particularly common in Mesolithic and Early Neolithic assemblages (Pitts and Jacobi 1979, 173), although their use continued into the Bronze Age (Saville 2002, 96). The choice of a blade blank for this example makes Mesolithic/Early Neolithic dating most probable. Although the lithics display only slight edge damage, all seem likely to have been redeposited. However, the trenches which contain flints (23, 42 and 119) are clustered in the centre of the eastern half of the excavation, so there may be a focus of Mesolithic or Early Neolithic activity in that area, which has been disturbed by subsequent activity.

Glass

- 6.39. Ten fragments of glass (272g) were recorded from five deposits. A small fragment (1g) of blue-green vessel glass was recovered from ditch 1506. It is the rim of a vessel the rim diameter (approximately 60mm) is suggestive of a narrow-mouthed vessel such as a jug or bottle, however due to its small size full identification is uncertain. The fragment is probably of Roman date. A fragment of pale green vessel glass is also thought to be of similar date. The fragment (ditch 11406) is square in plan (<20mm²) and may have been subjected to high temperature at some point after its initial manufacture as it contains large bubbles and appears misshapen. Ditch 14505 produced six fragments of transparent bottle glass (247g). The fragments are embossed with the letters 'SMITH & CO, [O]UNDL[E].' This most likely refers to Smith & Co brewery in Oundle, Northamptonshire. The company was founded in 1775, although the bottle fragments are most likely of 20th century date. A fragment of green bottle glass (quarry 7207) and a fragment of transparent window glass (ditch 20002) are both most likely of post-medieval or modern date.

Industrial waste

- 6.40. A total of 36 fragment of industrial waste, weighing 862g were recovered from six deposits. The industrial waste was recorded direct to an Excel spreadsheet, this forms part of the project archive. The assemblage was divided by context and examined macroscopically following standard guidance (Historic England 2015). It was quantified according to fragment count and weight per context.

Tap slag

- 6.41. Six fragments (351g) of iron flow slag were recovered from ditch 7102. The fragments exhibit evidence of flow on one side of the slag, with no evidence of ground impressions.

Partially burnt fuel

- 6.42. Three small fragments (6g) of partially burnt fuel were recovered from pit 14014. These were dark grey and very light weight; the fuel is potentially coal. Fragments of non-diagnostic slag from posthole 20938 and ditch 14204 have burnt coal within their composition.

Vitrified fuel ash

- 6.43. A total of 16 fragments (187g) of vitrified fuel ash (Historic England 2015) were recovered from ditch 13603. These fragments of industrial waste are light grey and spindly in appearance.

Cinder

- 6.44. Posthole 20938 produced 2 fragments (58g) of dark grey cinder (amorphous vitreous material that resembles non-diagnostic ironworking slag, which is noticeably less dense and more porous and vitrified than other slags (McDonnell 1983 and Keys 2012)).

Non-diagnostic iron working slag

- 6.45. There was a total of five fragments of non-diagnostic iron-working slags including the aforementioned fragments that contained burnt coal. They weighed a total of 260g. Most of the fragments cannot be positively identified as either smithing or smelting waste but are most likely the product of iron working. Ditch 14204 contained three fragments of non-diagnostic slag weighing 167g. Ditch 19007 produced a fragment of non-diagnostic slag (9g) that was recovered from sample 43. It is grey-green, dense and glittery in appearance, it has some possible flow but the finish shows

weathering. Posthole 20938 also produced one fragment of non-diagnostic ironworking slag (77g) as described in the partially burnt fuel section.

Summary

- 6.46. Several fragments of ironworking slag are present. The six fragments of tap slag from 7102 suggest a tap furnace in the vicinity, the rest of the ironworking slags lack a distinctive morphology that would show the process that formed them. Two of the fragments have partially burnt coal which is not commonly found in iron slags until the 18th century.
- 6.47. The cinder may have been created by any high-temperature process carried out on-site or nearby and is not direct evidence of ironworking in itself (Keys 2012). Posthole 20938 contains both cinder and non-diagnostic slag and may suggest that the cinder is the result of ironworking activity.
- 6.48. The vitrified fuel ash from 13603 does not appear to be metallurgical. While it does resemble fuel ash slag, this material can form when the inorganic residue from the combustion of an organic fuel reaches a high enough temperature to partially vitrify. Like cinder, this can be produced during iron smithing, but it can also be found on sites with no other evidence for metalworking.
- 6.49. There is little dating evidence for the features that contain industrial waste. However, ditch 13603 had a small group of pottery from the same context as the vitrified fuel ash. It included Roman pottery dating to between AD100-410. Posthole 20938 (cinder and the non-diagnostic ironworking slag with the partially burnt coal) cuts a ditch terminus containing 2nd century AD samian ware, making it likely that those fragments of industrial waste post-date the 2nd century.
- 6.50. A large amount of ironstone was recovered which may have been collected in the past with a view to being roasted/smelted, there was no evidence of such practices and so the fragments were discarded prior to quantification. The small quantity of industrial waste recovered suggests that ironworking was not a major activity in the vicinity of the site, especially when its geographical size is considered. Although the tap slag points to a probable bloomery smelting, the small amount recovered is only a fraction of the material that would be generated in a single smelt. As such the industrial waste is more indicative of low scale/domestic iron production, with the

cinder and vitrified fuel ash possibly being other domestic processes, rather than a primary industry of the area.

Stone

- 6.51. A total of three pieces of stone were retained (Table 1). A thick sarsen whetstone with a sub-triangular cross section was found in context 1200. This has been very heavily used so that all the faces are dished and the arrises are mostly sharp, with one that is rounded. Both ends have also been used. A small block of stone from context 15900 is probably structural but some shallow U-sectioned grooves on one face also its use for tool sharpening. The whetstones are not diagnostically datable but are likely to be Roman or medieval in date.
- 6.52. A single piece of grey-blue slate weighing 11g was recovered from context 7204. This is a small fragment and not diagnostic, but likely to be a fragment of stone roofing, which would suggest a medieval or post-medieval date.

Metalwork

- 6.53. A total of 32 metal objects weighing c. 613g (29 of iron, three of copper alloy) were recovered across 17 features, ranging in date from the Roman to modern periods. The latter consist of 14 ditches, a pit, a ring gully, a quarry and a floor surface.
- 6.54. Two metal objects are of Roman date. Registered Artefact 3 was recovered from ditch 11406, identifiable as a copper alloy radiate of the Gallic emperor Victorinus. This coin dates c. AD 269-271 and was struck at an uncertain Gallic mint (Reece period 13). Reverse type: [VIRTVS AVG], Virtus right with spear and shield (Bland et al. 2009/Cunetio, 149, no. 2553). In addition to this, a single iron hobnail was retrieved in sample 16 from ditch 11612, this originating from a piece of footwear (cf Crummy 1983, 51-52, cat. nos. 1821-1849) and datable only widely from the 1st-4th century AD.
- 6.55. Four objects are of post-medieval date. Two of these were recovered from fill layers within ditch 2703, comprising of a curved iron implement with a circular terminal and triangular-sectioned 'blade' (no RA assigned) and an incomplete cast copper alloy 'crotal' type animal bell of probable 18th century date (no RA assigned). Though the iron object could not be identified exactly, its association with the bell is suggestive of a post medieval date. Furthermore, a copper alloy milled 'old head' type halfpenny of George II dating c. 1741-1759 (RA 2) was recovered from Ring Gully 4216, while

a broken forged iron suspension hook with a perpendicular eye and twisted shank was excavated from Quarry 7207. Though loosely comparable with a Medieval find from Stretham (Goodall 2011, 335, J275), these objects are relatively ubiquitous - its overall construction and relatively uncorroded state suggest a later date is more appropriate.

- 6.56. Two objects are modern, a large quantity of what appears to be electrical wiring being recovered from ditch 14505 and an incomplete iron folding knife from ditch 14703 – the latter probably of 19th or 20th century date.
- 6.57. The remainder of the metal objects recovered from the site (24) could not be assigned to a specific period as a result of their state of preservation and/or undiagnostic nature. Of these, 22 comprise generic hand-forged iron carpentry nails corresponding to forms produced from the Roman to post-medieval periods. These are preserved in various conditions and states of completeness, all measuring between c. 28 and 85mm. While a cluster of 7 nails was recovered from ditch 11406, the others are scattered across a number of features – floor surface 1311 (1), ditches 7202 (1), 9402 (3), 11311 (2), 11418 (1), 11603 (1), 12404 (1), 14613 (1), 14704 (1), pit 14014 (1) and quarry 7207 (2). In addition to these, a flat, rectangular-sectioned fragment of an unidentifiable iron object was recovered from ditch 1304, while a further object probably best identified as two conjoining fragments of knife blade (RA 4) was recovered from ditch 20922. Neither of these objects can be dated accurately in their current state.
- 6.58. Despite its recovery from an archaeological feature, it is recommended that the electrical wiring from ditch 14505 be discarded due to its modern date.

Further work and selection strategy

- 6.59. The finds have been recorded in sufficient detail at this stage and no further work is required. The assemblage has the potential for further analysis and the pottery and flint are recommended for long-term curation. The CBM, fired clay and metalwork should be retained in the short-term and a decision made on its retention in light of any further works that may be carried out at the site. The remainder of the material (CBM and clay tobacco pipe) is not recommended for long-term curation.

7. THE BIOLOGICAL EVIDENCE BY ANDY CLARKE AND EMMA AITKEN

Animal bone

- 7.1. Animal bone amounting to 1109 fragments (19,119g) was recovered from 104 deposits, consisting predominantly of the fills of pit and ditch features. Artefactual material dating broadly to the Prehistoric, Iron Age, Late Iron Age/Early Roman transition and the Romano-British periods was also recovered from these features (See Table 1, Appendix C). The condition of the material varied, but in general the bone was highly fragmented and not well preserved. The combination of these factors has rendered 68% of the assemblage unidentifiable to element and species. However, it was possible to identify the remains of cattle (*Bos taurus*), sheep/goat (*Ovis aries/Capra hircus*), pig (*Sus scrofa*), horse (*Equus caballus*), domestic fowl (*Gallus sp.*) and dog (*Canis familiaris*). Two Associated Bone Groups (ABG) were also identified, consisting of a partial cattle skeleton and a dog skeleton. Where damage was present and re-fitting was possible, those bones were counted as a single fragment.

Neolithic

- 7.2. A single fragment of bone (7g) was recovered from deposit 4408 the fill of pit 4407. It was not identifiable to element or species.

Prehistoric

- 7.3. Seventy fragments (566g) were recovered from nine ditch and pit fill deposits, located mainly in areas M10 and PF7, that could only be dated broadly to the Prehistoric period. Cattle, sheep/goat, pig and horse were identified with each represented almost exclusively by meat-poor skeletal remains such as loose teeth or bone of the lower limbs. Any, or all of these species are to be expected in assemblages of this period, but with eight, three, six and two fragments respectively, the recovery too low to infer any information other than a species identification.

Iron Age

- 7.4. A total of 240 fragments (1845g) were recovered from the fills of 14 ditch, pit and post-hole features. As stated, the bone was fragmentary and not well preserved, rendering 75% of the Iron Age assemblage unidentifiable. Within the remaining identifiable portion, the bones of cattle and sheep/goat were most frequent with 25 and 17 fragments respectively. Each of these species were identified from mainly meat-poor elements, especially the mandible and the metapodials. Bones that are

high in meat-yield, like the scapula were also recovered, but in far fewer numbers. Evidence of butchery was rare, possibly because of the poor preservation. However, potential chop marks on a cattle radius from ditch fill 112, a sheep/goat radius from ditch 20919 and a cattle metacarpal from ditch fill 20923 do suggest a possible origin in butchery waste.

- 7.5. The remains of pig and horse were also identified but were recovered in amounts too low to provide any information other than species identification. Nine pieces (1g) of bird bone were recovered from ditch fill 11808. The fragments displayed the bright white colouration typical of prolonged burning and as a result were not identifiable to element or species.
- 7.6. The low recovery of identifiable bone severely limits the amount of useful information that the Iron Age assemblage can provide. However, the majority of the bone was recovered from the features that form either the potential settlement in Area PF7 or the small enclosure system in Area N8 (north), thus highlighting these two areas as the focus of activity during this period.

Late Iron Age/Early Roman

- 7.7. The character of the Iron Age assemblage remains stable and continues into the Late Iron Age/Early Roman transition. Ninety fragments (1239g) were recovered, 64% of which were unidentifiable to species. The remains of cattle and sheep/goat were most frequent with 17 and 10 fragments respectively consisting of a mix of mostly meat-poor and occasional meat-rich elements. The preservation of the bone was better in this phase and clear chop marks, indicative of the waste from secondary butchery, were observed on a cattle mandible, radius, humerus and pelvis from ditch fill 15907. The presence of horse and domestic fowl was confirmed from the recovery of two molar teeth and a partial tibio-tarsus.
- 7.8. The small amount of identifiable bone is a limiting factor in how much useful information can be obtained. However, once again the assemblage can be used to highlight areas of focussed activity. As with the preceding Iron Age bone, the majority of this material was recovered from Areas PF7 and N8 (North). In addition, two further areas of activity were highlighted with bone recovered from the enclosure features revealed in Areas M6 and N7.

Romano-British

- 7.9. The Roman activity on site accounts for the greater part of the assemblage with a total of 334 fragments (8272g) was recovered from 29 pit and ditch fill deposits revealed, as with the previous phases, in Areas M6, N8 (North) and PF7. The bone displayed a mixed level of preservation and was highly fragmented resulting in 61% being unidentifiable to element and species. The remains of cattle, sheep/goat, pig, horse and dog were identified, but were recovered in numbers and identified from elements that varied across the Areas.

Area M6 and Area N8 (North)

- 7.10. The bone recovered from the enclosure systems of Areas M6 and N8 (North) is dominated by the remains of cattle, almost to the exclusion of other species. A total of eight and twenty fragments were identified respectively in each Area, consisting exclusively of meat-poor skeletal elements, specifically fragments the mandible and the lower limbs. The bone was well preserved and displayed frequent cut marks, such as that seen on the metatarsal from ditch fill 15910 or the distal tibia from ditch fill 20911. Such damage is highly suggestive of the waste from primary butchery where bones that hold little or no meat are removed from the carcass. Sheep/goat and horse were also identified but were recovered in amounts too low to provide any information other than species identification.
- 7.11. The presence of dog on site was confirmed by the recovery of ABG 20943 from pit 20943 in Area N8 (North). The ABG consisted of a well preserved, articulated skeleton of a mature adult, together with a single femur from a second, but much smaller adult dog. The intention behind this deposition is unclear however, the burial of dogs was a common practice in this period (Morris 2011) and the inclusion of a bone from a second individual may indicate a deliberate, meaningful action.

Area PF7

- 7.12. The majority of the Roman assemblage (213 fragments, 4386g) was recovered from the fills of 12 ditch features that form part of the potential settlement In Area PF7. Once again, the remains of cattle were most frequent with 48 fragments (3096g) recovered. However, in contrast to Areas M6 and N8 the cattle bone in this area consisted of elements from throughout the skeleton, with bones both rich and poor in meat yield recovered in relatively equal amounts. Evidence of butchery was common with bones such the distal femur from 11413, displaying heavy chop marks indicative

of the use of a cleaver-like tool typical of this period. The remains of sheep/goat and pig were less frequent with 13 and 6 fragments each. None of this bone displayed any evidence of butchery but, like the cattle bone both species were identified from a mix of meat-poor and meat-rich elements. The presence of the three major domestic species, represented by a mix of skeletal elements both rich and poor in meat yield, many of which display chop marks, is highly suggestive of the waste from secondary butchery where a carcass is separated up into manageable portions of meat.

- 7.13. Taken as a whole, the Roman bone assemblage suggests an organised landscape. The bone recovered from Areas M6 and N8 consists of elements that would be among the first discarded in the butchery process, so potentially these enclosures were used to control, corral, and select animals for slaughter. Then after the removal of those bones that hold little or no meat, the butchery process continued once the carcass was moved to the settlement in Area PF7.

Undated

- 7.14. The remaining 347 fragments (7190g) in the assemblage were recovered from 38 deposits which remain undated. These deposits consist of the fills of the various pit, post-hole and ditch features revealed in Areas M6, M10, N8 (North) and PF7. In terms of species identified, evidence of butchery, preservation and fragmentation, this material shows a striking resemblance to the Iron Age and Roman assemblages described above and as such, is likely to originate from the same activity.
- 7.15. Of note among this material is ABG 11915 recovered from the fill of pit 11914. The bone was poorly preserved and highly fragmented, but it was possible to identify it as an almost complete skeleton of a mature cow. There was no indication of butchery or disease, but such marks may have been lost as the surface of the bone is extensively eroded. As a result, it is uncertain whether this represents a deliberate deposition or the disposal of an animal that has died from natural causes or been euthanised due to disease.

Marine shell

- 7.16. A total of three shell fragments, representing a minimum number of two individuals, were collected by hand excavation from two contexts from trenches 9 and 114. All shells have been tabulated by species and context and the results are summarised in Table 2 below. The species and habitat information follow that of Barret and Younge (1958).

7.17. All of the shells recovered were those of oyster (*Ostrea edulis*), a species found commonly in marine or brackish habitats such as on rocky shores and river estuaries. The quantity of marine shells retrieved from the site suggests that they were not likely to represent a major food source on this site during the Roman period, but rather occasionally augmented the local diet. The assemblage is too small to make any comments on the likely source of the shells and the nature of the oyster beds.

Statement of potential and recommendation for further work

7.18. There is no potential for obtaining more detailed information from this assemblage as the numbers of oyster shells recovered from each deposit are too low. For this reason, no further work is proposed on this assemblage.

Plant macrofossils

7.19. A total of 43 environmental samples were recovered from the site. Out of these 43, 16 were selected to be bulk processed (251 litres of soil) and five were selected to be processed by wet sieving (10 litres of soil) as these samples were determined to have the highest level of potential to yield environmental remains. The samples were taken to evaluate the preservation of palaeoenvironmental remains in the area and with the intention of recovering environmental evidence of industrial or domestic activity on the site. It was also hoped that the environmental remains may aid in the dating of some of the undated features on the site. The bulk environmental sample was processed by standard flotation procedures (CA Technical Manual No. 2) for the recovery of charred material, and the three waterlogged samples were processed by wet sieving (250-micron mesh size) (CA Technical Manual No.2) for the recovery of waterlogged material.

7.20. Preliminary identifications of plant macrofossils are noted in Table 3, following nomenclature of Stace (2019) for wild plants, and traditional nomenclature, as provided by Zohary *et al* (2012) for cereals. The presence of mollusc shells has also been recorded, following nomenclature according to Anderson (2005) and habitat preferences according to Kerney and (1999) and Davies (2008).

7.21. The flots varied in size from small to large with moderately low to high numbers of rooty material and uncharred seeds, which may be an indication of the level of risk of post-depositional movement of the environmental material. The burrowing snail species *Cecilioides acicula* was present in approximately half of the samples in small to large numbers which suggests that there may have been some post-depositional

movement within those features. The charred material comprised varying levels of preservation. Due to the poor to moderate preservation levels, it was difficult to identify many of the charred cereal grains to species, but where possible this was achieved.

- 7.22. Any dates discussed within this report have been obtained through the spot dating of the finds (see Rowlandson, this report).

Trench 1

- 7.23. Fill 110 from prehistoric ring gully 110 contained a small number of charcoal fragments and no other charred plant remains. This assemblage is indicative of wind-blow/dispersed waste material.

Trench 5

- 7.24. Sample 21 from prehistoric pit 503 contained a small number of charred weed seeds which includes those of vetch (*Vicia* sp.), red bartsia (*Odontites vernus*), and knotgrass (*Polygonum aviculare*) alongside a small number of charcoal fragments. This charred assemblage is likely to be reflective of wind-blown/dispersed waste material.

Trench 42

- 7.25. Two samples were recovered from Trench 42: sample 2 of possible prehistoric ring ditch 4220, and sample 3 from undated pit 4249. Pit 4249 was located in the centre of ring ditch 4220. Both samples contained no charred plant remains. Sample 2 of ring ditch 4220 contained a moderately large number of charcoal fragments which included those of non-oak. Sample 3 contained a smaller quantity of charcoal fragments. The environmental assemblage in sample 2 also contained a moderately small number of terrestrial snail shells belonging to the open country species *Vallonia* sp., *Pupilla muscorum*, *Vertigo* sp., the intermediate species *Cochlicopa* sp., and the shade-loving species *Aegopinella* sp., *Clausilla/Cochlodina* sp., and *Carychium tridendum*. The charred assemblages from samples 2 and 3 are likely to be reflective of small dumps of hearth waste material. The molluscan assemblage from sample 2 suggests a well-established open landscape with areas of longer grass, scrub, and hedgerow.

Trench 63

- 7.26. A single sample was recovered from possible prehistoric pit 6303 (sample 22). A single barley grain was noted during assessment alongside a small number of charcoal fragments. A large quantity of terrestrial snail shells were noted, including those of the open country species *Vallonia* sp., *Pupilla muscorum*, *Vertigo* sp., and *Helicella itala*, the intermediate species *Cochlicopa* sp., and *Pomatias elegans*, and the shade-loving species *Aegopinella* sp., *Discus rotundatus*, and *Carychium tridendum*. *Pomatias elegans* is found on disturbed ground and bare earth, and can indicate early clearance if found in a deposit of an early date. A small number of the marsh species *Carychium minimum* was also noted. The charred remains are likely to be indicative of wind-blown/dispersed waste material. The molluscan remains suggest an area that is made up of a well-established landscape which areas of damper ground/long grass and could indicate the stages of early clearance.

Trench 114

- 7.27. Fill 11413 (sample 11) of early prehistoric ditch 11406 contained a moderate number of charred cereal grains which includes those of hulled wheat (emmer or spelt (*Triticum dicoccum/spelta*)) and wheat (*Triticum* sp.). A very small number of charred weed seeds were observed within the assemblage and includes those of cabbage (*Brassica* sp.), oat/brome grass (*Avena/Bromus* sp.), and curled dock (*Rumex crispus*). All of these weed species are often found to be associated with late-stage crop processing activities. A small amount of charcoal was noted. Again, a number of snail shells belonging to the open country species *Helicella itala*, *Vallonia* sp., *Pupilla muscorum*, *Vallonia costata*, and *Vertigo* sp., the intermediate species *Cochlicopa* sp., and *Trochulus hispidus*, and the shade-loving species *Clausilla/Cochlodina* sp., and *Carychium tridendum* were noted within the assemblage alongside a small number of the marsh species *Succinea/Oxyloma* sp. The charred remains are likely to be indicative of a small dump of food production waste material.

Trench 116

- 7.28. The environmental assemblages recovered from possible Roman ditch 11612 contained a small number of indeterminate cereal grains, hulled wheat glume fragments, and a single charred seed of sheep's-sorrel (*Rumex acetosella*). The charred remains are indicative of wind-blown/dispersed waste material. A moderately small number of terrestrial snail shells were noted and include many of the same

species listed above. Additionally, the aquatic ditch species *Planorbis planorbis* and the shells of *Anisus leucostoma* were also noted, which suggests that this ditch went through periods of seasonal flooding and desiccation.

Trench 118

- 7.29. Fill 11808 (sample 8) of Late Iron Age ditch 11803 contained a small number of charred seeds, including those of oat/brome grass, elder (*Sambucus nigra*), bedstraw (*Galium* sp.), and clover/medick (*Trifolium/Medicago* sp.). A single nutlet fragment was recovered and has the preliminary identification of blackthorn (*Prunus spinosa*). Charcoal was also noted in small quantities. This assemblage is likely to be indicative of wind-blown/dispersed settlement waste material.

Trench 159

- 7.30. Two samples were recovered from Late Iron Age – Early Roman ditch 15904 (sample 31) and Roman ditch 15909 (sample 37). Both samples contained a small number of cereal grains, including those of hulled wheat and indeterminate wheat, as well as a small number of charred seeds. The weed seeds present include those of black mustard (*Brassica nigra*), meadow grass/cat's-tails (*Poa/Phleum* sp.) and charlock (*Sinapsis arvensis*). A large number of charcoal fragments were noted from sample 31, whilst sample 37 contained a small amount. Both assemblages contained terrestrial snail shells, including those of the open country species *Vallonia* sp., the intermediate species *Cepaea* sp., and the shade-loving species *Aegopinella* sp., *Discus rotundatus*, and *Carychium tridendum*. The charred assemblage from sample 31 is likely to be reflective of a dump of domestic hearth waste material, with the charred material from sample 37 being indicative of wind-blown/dispersed waste material. The molluscan assemblages from samples 31 and 37 indicate that the area was made up of a well-established open landscape with areas of longer grass/scrub.

Trench 190

- 7.31. Two samples were processed from Trench 190: sample 41 from possible Iron Age ditch 19003 and sample 43 from undated ditch 19007. Sample 43 contained no charred plant remains and only a minimal amount of charcoal. Sample 41 contained a small number of charred hazelnut (*Corylus avellana*) shell fragments and a single sheep's-sorrel seed alongside a small amount of charcoal. Both assemblages are likely to be reflective of wind-blown/dispersed waste material.

Trench 196

- 7.32. Sample 39 of Iron Age ditch 19604 contained no charred plant remains and only a sparse amount of charcoal.

Trench 197

- 7.33. Fill 19704 (sample 40) of undated ring ditch 19703 contained no charred plant remains and only a minimal amount of charcoal.

Trench 204

- 7.34. Sample 36 from possible Iron Age pit 20404 and sample 38 from possible Iron Age pit 20402 contained minimal amounts of charred plant remains, including indeterminate cereal grain fragments and a single bramble (*Rubus* sp.) seed. Both assemblages contained a small number of charcoal fragments alongside a small number of snail shells. These shells include those of the open country species *Vallonia* sp., and *Vallonia costata*, and the intermediate species *Trochulus hispidus*. The charred remains are likely to be indicative of wind-blown/dispersed waste material.

Trench 209

- 7.35. The environmental remains recovered from fill 20923 (sample 29) of Late Iron Age ditch 20922 contained a small number of cereal grains, including those of hulled wheat, and hulled wheat glume bases. A single charred bedstraw seed and a single red bartsia seed were also noted in the assemblage alongside several mineralised seeds of black mustard. Charcoal was noted in moderately large quantities. The molluscan assemblage observed indicates that this area was prone to seasonal flooding and desiccation due to the presence of the aquatic snail shell *Anisus leucostoma*.
- 7.36. Late Iron Age posthole 20912 (sample 30) contained a small number of wheat grains and a moderate quantity of charcoal fragments. The charcoal assemblage contained fragments of oak (*Quercus* sp.) and non-oak wood. Terrestrial snail shells belonging to the intermediate species *Trochulus hispidus*, and the shade-loving species *Ena/Merdigera* sp., *Discus rountundatus* and *Carychium tridendum* were noted in small quantities.

-
- 7.37. Sample 34 from possible Roman posthole 20940 contained a sparse amount of charred plant remains, including that of a single cherry (*Prunus* sp.) stone. Charcoal was observed in moderate quantities and contained fragments of oak wood.
- 7.38. The charred material recovered from the assemblages in Trench 209 are all likely to be reflective of small dumps of domestic hearth waste material.

Summary

- 7.39. There is some limited evidence suggesting that domestic settlement activities were taking place within the nearby vicinities of Trenches 42, 114, 159, and 209. There is also evidence that harvesting by sickle (Hillman 1981) may have been the common practice and is a typical harvesting technique during the Roman period. This is seen by the presence of low growing species, such as clover or medick and docks.
- 7.40. The remaining trenches were likely to have been situated on the outskirts of the areas of settlement activity, which might account for some of these dispersed assemblages containing plant remains associated with domestic settlement activities (such as cereal grains).
- 7.41. Due to the paucity of the charred remains recovered from the undated features, it is not possible to determine a potential date.
- 7.42. The molluscan assemblages noted during this assessment indicate that the area is made up of a well-established open landscape with areas that are prone to seasonal flooding and desiccation or are often very damp. There is some evidence that longer grass/scrub was also in the area.

8. DISCUSSION

- 8.1. The main focal areas of archaeological activity identified by the trenching were accurately predicted by the geophysical survey, particularly in field parcels M6, M10, PF7 and N7 and N8. Archaeologically relatively quiet or blank areas indicated by the geophysical survey also were confirmed as such by the results of the trial trenching. However, not all areas predicted by the geophysical survey to contain archaeological remains did so; for example, Trenches 33 to 39, in field parcel M10, contained only a single archaeological feature despite having been targeted at a cluster of anomalies morphologically suggestive of a trackway, enclosures and a possible ring ditch. Similarly, Trenches 136 – 138 in land parcel PF8 and Trenches 183 – 188 in land

parcel N8 also contained no archaeological remains despite the presence of morphologically suggestive geophysical anomalies.

- 8.2. In respect of this, across the majority of the trenching areas high levels of modern plough truncation, plough scarring and evidence for wheel rutting were observed. In field parcel M6 in particular, quantities of artefactual material were noted in the ploughsoil in the vicinity of the trenches, suggesting plough erosion of the underlying remains was actively occurring. Particularly heavy plough scarring was also noted across land parcels P1 and M11. Consequently, it is conjectured that some of the anomalies identified by the geophysical survey, where not clearly related to geological variations etc, may be the result of ploughed-out archaeological features surviving as soil bands in the agricultural plough soil.
- 8.3. The remains encountered in the trenches were shown to be predominantly Iron Age and Roman in date, with little evidence for activity pre- or post-dating these periods being identified. The principal exception to this was a set of curvilinear ditches and associated features in field parcel M10 (Trenches 40, 42 and 45), where a double ring ditch identified by the geophysical survey and targeted by Trench 42, appears to be Late Neolithic/ Early Bronze Age in date. Thought on morphological grounds to be a possible burial mound, the absence of any burial pit within the central area of the inner ditch, coupled with evidence for the recutting of both the inner and outer ditch and the presence of pottery and animal bone in the ditches and nearby (seemingly associated) features imply a non-funerary function for the enclosure. Notably, the ring ditch re-cuts appeared to indicate a reversal in the comparative dimensions of the two ditches. The inner ditch re-cut was considerably larger in size than the first iteration, while the outer ditch was larger during its initial iteration and appeared to be downsized during the re-cutting. The presence of Neolithic to Middle Bronze Age incised ware pottery from a pit in Trench 44, in this area, is of note.
- 8.4. A total of ten worked flints were recovered during the evaluation, all deemed likely to have been redeposited, although it was noted that the trenches that contained flints (23, 42 and 119) are clustered in the central part of the eastern half of the Site. It is therefore possible that there may be a focus of Mesolithic or Early Neolithic activity in that area, which has been disturbed by subsequent agricultural activity.
- 8.5. In field parcel M6, an area of Late Iron Age and Early Roman activity was encountered, including a possible stone surface and large quantities of artefacts. The

animal bone recovered from this area was dominated by the remains of cattle, almost to the exclusion of other species, consisting exclusively of meat-poor skeletal elements, specifically fragments the mandible and the lower limbs. The bone was well preserved and displayed frequent cut marks; such damage is highly suggestive of the waste from primary butchery where bones that hold little or no meat are removed from the carcass.

- 8.6. A dense area of geophysical anomalies investigated in field parcel PF7 translated into a large number of intercutting ditches, pits, and occupation horizons. The density of features in this area, and the scale and variety of the finds recovered from the features, suggests the presence of a small settlement, possibly a farmstead. Pottery evidence indicates activity at this location from the Late Iron Age onwards, spanning the Iron Age – Roman transition and on into the 3rd – 4th century, although it is not clear if this was truly continuous. In contrast to field parcel M6 the cattle bone consisted of elements from throughout the skeleton, with bones both rich and poor in meat yield recovered in relatively equal amounts. Evidence of butchery was common with bones displaying heavy chop marks highly suggestive of the waste from secondary butchery where a carcass is separated up into manageable portions of meat.
- 8.7. Seemingly contemporary remains to the settlement in PF7 were recorded to the south-east, in field parcels N7/N8 and N11, although a lower level of activity was seen, predominantly comprising enclosure and field boundary ditches. Of note in relation to field parcel N7, while the geophysical survey suggested the presence of likely Iron Age – Roman remains in the area targeted by trenches 139 to 147, a number of the features investigated in this area contained industrial waste of likely 18th century or later date, while the ditch at the southern extent of the suggested ring ditch in trench 145 contained a variety of modern material including electrical wire.
- 8.8. However, the remains of a building of Roman date were encountered in field parcel N8, comprising a cluster of postholes and associated small ditches, including a segment of possible beam slot/ foundation trench for an earthfast building. As with the remains in land parcel PF7, pottery of Late Iron Age, Late Iron Age – Early Roman transition and 3rd – 4th century date was recovered from this site with pottery of Late Iron Age – Early transitional date recovered from the structural postholes suggesting that the building may have been constructed in the 1st century AD. Animal bone from

this site was again almost entirely cattle and displayed signs of primary butchery, suggesting the Iron Age – Roman activity in parcels M6 and N8 may represent satellite centres of activity to the main settlement focus in PF7 and were primarily involved in stock raising/ primary butchery, the butchered meat then being consumed at the PF7 settlement.

- 8.9. Although no clear evidence was encountered for the continued occupation of the PF7 settlement and surrounding associated field systems beyond the late Roman period, a small number of pot sherds of possible post-Roman date may indicate a low level of activity into the Saxon period. The area subsequently appears to have formed part of the agricultural landscape surrounding the small medieval settlements at Essendine and Ryhall and continued as agricultural land through the post-medieval and modern periods. In respect of this land use, a number of furrows, infilled field boundary ditches and likely extraction pits were identified across the evaluation area.
- 8.10. In respect of the pottery assemblage, the Neolithic to Middle Bronze Age incised wares from trenches 44 represent the only coherent, sizeable group of early pottery from the evaluation. A small range of Iron Age pottery was also recovered, most of the groups being small and fragmentary; the best assemblage, both in terms of the presence of diagnostic vessel forms and preservation, originated from features in Trench 209, in Area N8, in the immediate vicinity of the likely 1st century Roman building. The Roman assemblage was similar to what might be expected from a basic rural assemblage from the Rutland/Lincolnshire border, and matches material recovered from other similar sites in the area. The vast majority of wares present were locally produced, with few mortaria, amphora or imported fine ware sherds.
- 8.11. The relatively small assemblage (25 fragments) of ceramic building material appears to mostly date to the Roman period, including fragments of tegula and imbrex roof tiles. However, given that such small quantities of material were recovered it would appear that there are no highly Romanised structures/buildings in any of the evaluated areas. Only three fragments of CBM could be firmly dated to the post-medieval or modern period.
- 8.12. The fired clay assemblage (74 fragments) was predominantly undiagnostic, although a small number of fragments were observed to have smoothed or flat surfaces and several contained rod-like impressions, probably representing fragments of burnt daub. This includes pieces recovered from postholes in trench 209 which were

interpreted as forming part of a building. A fragment of a kiln bar recovered from a ditch in Trench 30 also hints at pottery production in the vicinity during the Roman period.

- 8.13. The small quantity of industrial waste recovered suggests that ironworking was not a major activity in the vicinity of the site, especially when its geographical size is considered. Although the tap slag points to a probable bloomery smelting, the small amount recovered is only a fraction of the material that would be generated in a single smelt. As such the industrial waste is considered more indicative of low scale/domestic iron production, with the cinder and vitrified fuel ash possibly being other domestic processes, rather than a primary industry of the area.
- 8.14. A substantial assemblage of animal bone was recovered from features across the evaluation area, with a particular focus on the settlement in Area PF7 and evidence for specific, primary butchery, activities taking place within the enclosures in area M6 and N8. In general, the 310 total fragments of bone recovered from earlier prehistoric and Iron Age features were fragmentary and poorly preserved, rendering them for the most part unidentifiable. However, some fragments of cattle and sheep/goat could be identified from mainly meat-poor elements, with very limited evidence for butchery. Fragments of pig, horse, and burnt bird bones were also recovered, but were too poorly preserved to facilitate any interpretation beyond basic species identification.
- 8.15. During the Roman period, activity within the Site appeared to intensify, based on the animal bone assemblage, and a spatial separation of elements and species became more apparent within the assemblage. As noted above, in Areas M6 and N8 the assemblages were dominated by the remains of cattle, almost to the exclusion of other species, and comprised exclusively meat-poor skeletal elements. The bone was well preserved and displayed frequent cut marks, suggestive of the waste from primary butchery where bones that hold little or no meat are removed from the carcass.
- 8.16. In Area PF7, cattle were once again the most common species identified, although in this area comprising elements from throughout the skeleton, with bones both rich and poor in meat yield recovered in relatively equal amounts. Evidence of butchery was common, with heavy chop-marks indicating the use of period-typical cleaver-like tools.

-
- 8.17. On the whole, the Roman bone assemblage suggests a highly organised livestock-based landscape. The bone recovered from Areas M6 and N8 consists of elements that would be among the first discarded in the butchery process, so potentially these enclosures, located in the periphery of the core settlement, were used to control, corral, and select animals for slaughter. Then after the removal of those bones that hold little or no meat, the butchery process continued once the carcass was moved to the settlement in Area PF7.
- 8.18. The environmental remains recovered from bulk samples across the trenching areas provide some, albeit limited, supporting evidence that domestic settlement activities were taking place within the nearby vicinities of Trenches 42, 114, 159, and 209. The presence of low growing species, such as clover or medick and docks also suggests that harvesting by sickle may have been the common practice; this is a typical harvesting technique during the Roman period. The remaining trenches were likely to have been situated on the outskirts of the areas of settlement activity, which might account for some of these dispersed assemblages containing plant remains associated with domestic settlement activities (such as cereal grains).
- 8.19. Given the evidence for occupation within the Site potentially ranging from the Late Neolithic/ Early Bronze Age to the Roman period and beyond then in addition to the research theme/ contributions identified by Rowlandson in section 6 above, there is the potential for further archaeological work on the evaluated sites to contribute to a number of research objectives identified within the *East Midlands Historic Environment Research Framework*. This particularly includes the following research themes:
- **Late Bronze Age/Iron Age:** 4.6.1 (development of field and boundary systems); 4.8.1 (processes of woodland clearance/agricultural intensification); 4.8.2 (variation in diet and land-use over time);
 - **Romano-British:** 5.4.4 (development and changing patterns in field and boundary systems); 5.4.5 (patterns of settlement locations in the landscape);
 - **Early medieval:** 6.7.1 (agricultural changes during the Roman/Saxon transition).
- 8.20. In the event that further targeted phases of fieldwork were to be carried out within the Site, the combined data obtained from all fieldwork phases should be assessed with

reference to the research framework in order to identify any additional contributions which might be made.

9. CA PROJECT TEAM

9.1. Fieldwork was undertaken by Anna Wolf, Joan Roig, Joao Heitor and Jack Martin-Jones, assisted variously by Rachel Alexander, Sam Cross, Ben Carrick, Nick Botschin, Ben Allen, Dominic Allen, Karri Hynds, Edward Aylott, Chris Aland, Signe Lund, and Francesca Broom, as well as cross-hired staff from ECUS Ltd. This report was written by Anna Wolf. The finds reports were written by Alistair Barclay, Alex Bliss, Jacky Sommerville, Pete Banks, Ian Rowlandson and H.G. Fiske, Ruth Shaffrey and David Dungworth with Stephen Knowles; and the biological evidence reports were authored by Andy Clarke and Emma Aitken. The report illustrations were prepared by Ryan Wilson. The project archive has been compiled and prepared for deposition by Molly Agnew-Henshaw. The project was managed for CA by Adrian Scruby.

10. REFERENCES

- Addyman, P.V., Fennell, K.R. and Biek, L., 1964, A Dark-Age Settlement at Maxey, Northants., *Medieval Archaeology* 8 issue 1, 20-73
- Allen, C.S., Harman, M. and Wheeler, H. 1987, Bronze Age cremation cemeteries in the East Midlands, *Proceedings of the Prehistoric Society* Vol. 53, p187-221
- Anderson, R. 2005 'An annotated list of the non-marine Mollusca of Britain and Ireland', *Journal of Conchology* 38, 607-637
- ADS (Archaeology Data Service) 2021 *Guidelines for Depositors*
- Barclay, A., Knight, D., Booth, P., Evans, J., Brown, D.H. and Wood, I., 2016, *A Standard for Pottery Analysis in Archaeology*, Published by Medieval Pottery Research Group, Prehistoric Ceramics Research Group and Study Group for Roman Pottery
- Barrett, J.H and Yonge, C.M. 1958 *Collins pocket guide to the sea shore* London, Collins

BGS (British Geological Survey) 2022 *Geology Viewer*

[REDACTED]
[REDACTED] Accessed 26 January 2023

Biddulph, E., Foreman, S., Stafford, E., Stansbie, D., Nicholson R., 2012 *London Gateway: Iron Age and Roman salt making in the Thames Estuary. Excavation at Stanford Wharf Nature Reserve* Oxford, Oxford Archaeology Report [REDACTED] (accessed 17th January 2023)

Bland, R, Besly, E, Burnett, A and Moorhead, S. 2009 *The Cunetio and Normanby Hoards* London, Dept. of Portable Antiquities and Treasure

Blinkhorn, P., 2000, The Early Anglo-Saxon Pottery, in *Cooper 2000a.*, 98-104

Butler, C. 2005 *Prehistoric Flintwork* Stroud, Tempus

CA (Cotswold Archaeology) 2012 *The taking and processing of environmental and other samples from archaeological sites* Technical Manual No. 2

CA (Cotswold Archaeology) 2022 *Mallard Pass Solar Farm, Essendine, Rutland: Heritage Desk-Based Assessment* CA ref. MK0487_1 (in prep)

CIfA (Chartered Institute for Archaeologists) 2019 *Code of Conduct*

CIfA (Chartered Institute for Archaeologists) 2020a *Standard and guidance for commissioning work or providing consultancy advice on archaeology and the historic environment*

CIfA (Chartered Institute for Archaeologists) 2020b *Standards and guidance for field evaluation*

CIfA (Chartered Institute for Archaeologists) 2020c *Standard and guidance for the creation, compilation, transfer and deposition of archaeological archives*

CIfA 2022 '*CIfA Toolkit for Specialist Reporting*'

[REDACTED] (accessed 28 November 2022)

Clark, R., 1999, The Roman Pottery, in Connor, A. and Buckley, R., *Roman and Medieval Occupation in Causeway Lane, Leicester*, Leicester Archaeology Monographs No. 5, Leicester, 95-164

-
- Cooper, N.J., 2000a, *The Archaeology of Rutland Water: Excavations at Empingham in Gwash Valley, Rutland, 1967-73 and 1990*, University of Leicester Archaeological Services, Leicester
- Cooper, N.J., 2000b, The Iron Age Pottery, in *Cooper, 2000a*, 67-71
- Cooper, N.J., 2000c, The Roman Pottery, in *Cooper 2000a*, 72-97
- Cooper, N. J. 2004, Pottery, Landscape and Trade: What are the sherds telling us?, in Bowman, P., Liddle, P. (eds.) *Leicestershire Landscapes*, Leicestershire Museums Archaeological Fieldwork Group Monographs, No. 1, pp. 81-94
- Crummy, N. 1983 *Colchester Archaeological Report 2: The Roman small finds from excavations in Colchester, 1971-9*. Colchester, Colchester Archaeological Trust
- CSIRA., 1955 *The Blacksmith's Craft. An introduction to smithing for apprentices and craftsmen*. Revised edition. Salisbury: The Council for Small Industries in Rural Areas
- Daniel, P., 2016, Exeter Down, Stamford, an Early to Middle Iron Age Enclosed Settlement with Evidence of Iron Smelting, *Lincolnshire History and Archaeology*, 51, 45-52
- Dannell, G., 1973, *The Potter Indivivixus* in Detsicas A.P. (ed), Current Research in Romano British Coarse Pottery. Council for British Archaeological Research Report 10, Oxford: CBA, 139-41
- Darling, M.J., 2004a, Guidelines for the archiving of Roman Pottery, *Journal of Roman Pottery Studies* 11, 67-74.
- Darling, M.J. and Precious, B.J., 2014, *A Corpus of Roman Pottery from Lincoln*, Lincoln Archaeological Studies No. 6, Oxbow Books, Oxford
- Darling, M., Rowlandson I.M., and Fiske, H.G. with Wild, F.C and Monteil, G., 2020, Roman pottery, in Atkins, R., Burke, J., Field, L. and Yates, A., *Middle Bronze Age and Roman Settlement at Manor Pit, Baston, Lincolnshire: Excavations 2002-2014*, Archaeopress, Oxford 102-130
- Davies, P. 2008 *Snails Archaeology and Landscape Change*, Oxford, Oxbow Books

-
- Dodd, M. 2015 *Final Report on an Archaeological Strip, Plan and Record Excavation at Ryhall Substation, Cable Trench Route, Rutland*. Trent & Peak Archaeology: Nottingham
- Goodall, I, H. 2011 *Ironwork in Medieval Britain: an Archaeological Study* The Society for Medieval Archaeology, monograph 31. London, SMA
- Great Casterton Parish Council 2022 *History of the Village from Roman Times*
[REDACTED] (accessed 09/05/2022)
- East Midlands Historic Environment Research Framework 2022
[REDACTED]
[REDACTED]
- Elsdon, S.M., 1996a, *Iron Age Pottery in the East Midlands, a Handbook*, Dept of Classics and Archaeology, University of Nottingham
- Firman, R. and Leary, R.S., 2001, Petrology of Ockbrook sherds: summary and interpretation, in Palfreyman, A., Report on the excavation of a Romano-British aisled building at Little Hay Grange Farm, Ockbrook, Derbyshire 1992-95, *Derbyshire Archaeological Journal* 121, 121-130
- Gillam, J. P., 1970, *Types of Coarse Roman Pottery Vessels Found in Northern Britain*, 3rd ed, University of Newcastle upon Tyne, Newcastle upon Tyne
- Hillman, G. C. 1981 Reconstructing crop husbandry practices from charred remains of crops in R. Mercer (ed.) 1981, 123–162
- HE (Historic England) 2015a *Management of Research Projects in the Historic Environment (MoRPHE) PPN 3: Archaeological Excavation*
- HE (Historic England) 2015b *Management of Research Projects in the Historic Environment: The MoRPHE Project Managers' Guide*
- HE (Historic England) 2015c *Digital Image Capture and File Storage: Guidelines for Best Practice*
- HE (Historic England) 2015d *Archaeometallurgy. Guidelines for best practice*
London, Historic England
- Jackson, D.A. and Dix, B., 1987, Late Iron Age and Roman settlement at Weekley, Northants., *Northants. Archaeol.*, 21, 41-94

-
- Jackson, D.A. and Knight, D., 1985, An Early Iron Age and Beaker site near Gretton, Northamptonshire, *Northamptonshire Archaeology*, 20, 67-86
- Jennings, L. (ed), 2019, *Lincolnshire County Council Archaeological Handbook* revised 2019 (original release 1998), Lincolnshire County Council, Lincoln available on-line <https://www.lincolnshire.gov.uk/historic-environment/archaeological-handbook>
- Johnson 2009b, The Roman Pottery, in Morris, Cooper & Buckley (eds) 2009: *Life and Death in Leicester's North-east Quarter Excavation of a Roman Town House and Medieval Parish Churchyard at Vine Street, Leicester (Highcross Leicester) 2004-2006, Vol. 2*, ULAS Report No. 2009-134, 1-97
- Kerney, M.P. 1999 Atlas of the Land and Freshwater Molluscs of Britain and Ireland, Colchester, Harley
- Keys, L. 2012 'Specialist report 6: slag and high-temperature debris' in Biddulph et al. 2012 **6**, 1-10
- Knight, D. 1998, Guidelines for the Recording of Later Prehistoric Pottery from the East Midlands, unpublished Trent and Peak Archaeology report
- Knight, D. 2002, A Regional Ceramic Sequence: Pottery of the First Millennium BC between the Humber and the Nene, in), Woodward, A. and Hill, J.D. (eds), 2002, *Prehistoric Britain: The Ceramic Basis*, Prehistoric Ceramics Research Group Occasional Publication 3, Oxbow, Oxford, 119-142
- Knight, D., Vyner, B. and Allen, C., 2012, *East Midlands Heritage: An Updated Research Agenda and Strategy for the Historic Environment of the East Midlands*, University of Nottingham and York Archaeological Trust
- Lane, T. and Trimble, D., 2010, *Fluid Landscapes and Human Adaptation: Excavations on Prehistoric Sites on the Lincolnshire Fen Edge 1991-1994*, Lincolnshire Archaeology and Heritage Reports Series 9, Heritage Trust for Lincolnshire
- Leicestershire Archaeological and Historical Society 2015 'The Roman and Anglo-Saxon Cemetery at Great Casterton: The 1966 Excavation' In, *Transactions of the Leicestershire Archaeological and Historical Society, Volume 89*. pp73-106, pp108-109

-
- Liddle, P. 1983 'Archaeology in Leicestershire and Rutland 1983' In, *Transactions of the Leicestershire Archaeological and History Society. Volume 58.*
Leicestershire Archaeological and History Society
- Magnitude (Magnitude Surveys) 2022 *Geophysical Survey Report. Mallard Pass Solar Farm DCO, Essendine, Rutland* Magnitude Surveys ref. MSTF1136A
- Marsden, P., 2011, The Prehistoric Pottery and Briquetage, Thomas, J., *Two Iron Age 'Aggregated' Settlements in the Environs of Leicester: Excavations at Beaumont Leys and Humberstone*, Leicester Archaeology Monograph No. 10, Leicester, 61-80
- McDonnell, J. G. 1983 'Tap slags and hearth bottoms' *Current Archaeology* **86**, 81–83
- Meaney, A. 1964 *Gazetteer of Early Anglo-Saxon Burial Sites*
- Mercer, R. (ed.) 1981 *Farming practice in British prehistory*, Edinburgh, Edinburgh University Press
- MHCLG (Ministry of Housing, Communities & Local Government) 2021 *National Planning Policy Framework*
- Morris, J. 2011 *Investigating Animal Burials: Ritual, mundane and beyond*. BAR British Series 535
- Page, W. 1935 'Parishes: Essendine' In, *A History of the County of Rutland: Volume 2, pp. 250-254. British History Online* [REDACTED]
[REDACTED]
- PCRG, 1997, *The Study of Later Prehistoric Pottery: General Policies and Guidelines for analysis and Publications*, Prehistoric Ceramic Research Group, Occasional Paper No1 and No2, Revised 1997
- Percival, S., 2020, Atkins, R., Burke, J., Field, L. and Yates, A., 2020, *Middle Bronze Age and Roman Settlement at Manor Pit, Baston, Lincolnshire: Excavations 2002-2014*, MoLA Northampton monograph, 88-102
- Perrin, J. R., 1999, Roman Pottery from Excavations at and near to the Roman Small Town of Durobrivae, Water Newton, Cambridgeshire, 1956-58, *Journal of Roman Pottery Studies* 8

-
- Pitts, M. W. and Jacobi, R. M. 1979 'Some aspects of change in flaked stone industries of the Mesolithic and Neolithic in Southern Britain', *J. Archaeol. Sci.* **6**, 163–77
- Pollard, R., 1994, The Late Iron Age and Roman Pottery in P. Clay and R. Pollard, *Iron Age and Roman Occupation in the West Bridge Area, Leicester, Excavations 1962-1971*, Leicester Archaeology Monographs No. 5, University of Leicester, 51-114
- Pollard, R. 1999 *Roman Pottery in Leicestershire. Leicestershire Museums Fabric Type Series. A Concordance with the National Roman Fabric Reference Collection and selected other series*, Unpublished research document
- Rowlandson, I.M., 2015, The pottery, in Burgess, A., Iron Age and Romano-British Sites along the A453 between Barton in Fabis and Clifton, Nottinghamshire, *Transactions of the Thoroton Society*, 119, 57-102
- Rowlandson, I.M., with Darling M.J. and Monteil, G., 2011, The Roman pottery, in Palmer-Brown, C. and Rylatt, J., *How Times Change: Navenby Unearthed*, PreConstruct Archaeological Services Ltd. Monograph No. 2, Saxilby, 73-101
- Rowlandson, I.M., 2017, The Pottery, in Weston, P. and Daniel, P., *Stamford West Lincolnshire: Archaeological Excavation*, Wessex Archaeology developer funded report, 15-26
- Rowlandson, I.M., 2019, *A1 Spittlegate Junction, Lincolnshire (GRSP17)*, Unpublished Assessment report for Allen Archaeology Ltd
- Rowlandson, I.M., and Fiske, H.G., 2022, *The Pottery Assemblage: an assessment* [Pottery from the Grantham Southern Quadrant scheme site code GSQ16], unpublished assessment for AOC Archaeology
- Samuels, J., 1983, *The Production of Roman Pottery in the East Midlands*, Unpublished PhD, Nottingham University
- Saville, A. 2002 'Lithic artefacts from Neolithic Causewayed Enclosures: Character and meaning' in Varndell, G. and Topping P., 91–105
- Stace, C. 2019 *New flora of the British Isles*, 4th edition Cambridge: Cambridge University Press

-
- Swan, V. 2023 'The pottery kilns of Roman Britain: Market Overton, Rutland'
[REDACTED] (accessed 13 January 2023)
- Varndell, G. and Topping P. 2002 *Enclosures in Neolithic Europe: Essays on Causewayed and Non-Causewayed sites* Oxford, Oxbow Books
- Young, J., 1996, Report on the Pottery from Excavations at Quarrington 1993, in Walker, F. and Lane, T., *An Early and Middle Saxon Settlement at Quarrington, Lincolnshire: Volume III The Specialist Reports*, APS Report No. 49/96, [REDACTED]
- Young, J. and Vince, A, with Nailor, N., 2005, *A Corpus of Anglo-Saxon and Medieval Pottery from Lincoln*, Lincoln Archaeological Studies No.7, Oxbow Books, Oxford
- Zohary, D., Hopf, M. and Weiss, E. 2012 *Domestication of plants in the Old World: the origin and spread of cultivated plants in West Asia, Europe, and the Nile Valley*, 4th edition Oxford, Clarendon Press

APPENDIX A: CONTEXT DESCRIPTIONS

Trench No.	Context No.	Fill of	Context type	Interpretation	Comments	Length (m)	Width (m)	Depth (m)
1	100		layer	Ploughsoil	Mid grey brown, silty clay, friable	50	2	0.29
1	101		layer	Natural	Mid brown yellow, silty clay, compact with occasional flint and stones	50	2	
1	102		cut	Ditch	Linear N-S. Concave sides and with mostly flat base	>1	1	0.26
1	103	102	fill	Secondary Fill	Mid brown red, sandy silt, loose, occasional charcoal flecks and limestones	>1	1	0.26
1	104		cut	Ditch	Linear N-S. Steep edges with concave base	>1	0.48	0.24
1	105	104	fill	Secondary Fill	Mid red brown, sandy silt, loose, occasional limestones	>1	0.48	0.24
1	106		cut	Pit	Circular in plan. Steep edges with concave base	0.6	1.22	0.42
1	107	106	fill	Secondary Fill	Dark brown, sandy silt, loose, occasional limestone	1.22	1.22	0.42
1	108		cut	Natural Feature		>2		
1	109		cut	Ditch	Curvilinear NW-SE. Gradual slopes with concave base	>1	0.3	0.1
1	110	109	fill	Secondary Fill	Mid red brown, sandy silt, soft, occasional small limestones and frequent fired clay	>1	0.3	0.1
1	111		cut	Ditch	Linear NE-SW. Steep slopes with concave base	>1	1.72	0.63
1	112	111	fill	Secondary Fill	Mid grey brown, silty clay, soft, occasional charcoal and stones	>1	1.72	0.63
1	113		unexcavated feature	Ditch	Linear N-S. Fill is mid brown grey, sandy silt, friable, occasional small stones	>2.3	1.5	
2	200		layer	Ploughsoil	Mid grey brown, clayey silt, friable	50	2	0.18
2	201		layer	Subsoil	Light brown grey, clayey silt, friable	2.2	2	0.1
2	202		layer	Natural	Mid brown yellow, silty clay, compact with occasional flint and stones	50	2	
2	203		cut	Ditch	Linear NW-SE. Steep edges with concave base	>2.2	1.14	0.38
2	204	203	fill	Secondary Fill	Mid yellow grey, silty clay, compact, occasional small rounded stones	>2.2	0.56	0.16
2	205	203	fill	Secondary Fill	Dark brown grey, silty clay, firm, occasional charcoal flecks and small to medium rounded stones	>2.2	1.14	0.34
2	206		cut	Natural Feature	Unknown shape in plan. No edges and uneven base	>1	1.3	0.3
2	207	206	fill	Secondary Fill	Mid brown orange, silty clay, firm, frequent small rounded stones	>1	1.3	0.3
2	208		layer	Other Layer	Dark brown, sandy clay, firm, occasional small stones and rare charcoal flecks	>2	10.5	0.27
2	209		void					
2	210		cut	Ditch	Linear N-S. Steep edges with concave base	>1.1	2.54	0.53
2	211	210	fill	Secondary Fill	Dark brown, sandy silt, loose, occasional limestone	>1.1	1.16	0.24
2	212	210	fill	Secondary Fill	Mid yellow grey, silty clay, compact, occasional small rounded stones	>1.1	0.46	0.16
2	213	210	fill	Secondary Fill	Dark brown grey, silty clay, firm, occasional charcoal flecks and small to medium rounded stones	>1.1	2	0.53

3	300		layer	Ploughsoil	Mid grey brown, silty clay, friable	50	2	0.19
3	301		layer	Subsoil	Light brown grey, silty clay, friable	50	2	0.1
3	302		layer	Natural	Mid brown yellow, silty clay, friable, occasional stones and flint	50	2	
4	400		layer	Ploughsoil	Mid grey brown, silty clay, friable	50	2	0.2
4	401		layer	Subsoil	Light brown grey, silty clay, friable	50	2	0.1
4	402		layer	Natural	Mid brown yellow, silty clay, compact, occasional flint and stones	50	2	
5	500		layer	Ploughsoil	Dark grey brown, silty clay, friable	50	2	0.3
5	501		layer	Subsoil	Mid grey brown, sandy clay, moderately compact with frequent limestone	50	2	0.5
5	502		layer	Natural	Mid yellow brown, sandy clay, moderately compact with frequent limestone and flint	50	2	
5	503		cut	Pit	Circular in plan. Gentle slopes. with concave base	1.1	1.1	0.19
5	504	503	fill	Deliberate Backfill	Mid grey brown, silty clay, firm, moderate charcoal flecks and flint	1.1	1.1	0.19
6	600		layer	Ploughsoil	Dark grey brown, silty clay, friable	50	2	0.2
6	601		layer	Subsoil	Mid grey brown, sandy clay, moderately compact with frequent limestone	50	2	0.2
6	602		layer	Natural	Light grey, silty clay with gravel patches, friable	50	2	
6	603		cut	Ditch	Linear N-S. Steep edges with concave base	>7	1.56	0.51
6	604	603	fill	Other Fill	Mid yellow brown, silty sand, loose	>7	0.22	0.32
6	605	603	fill	Secondary Fill	Mid brown yellow, silty sand, friable, rare small rounded stones	>7	0.95	0.17
6	606	603	fill	Secondary Fill	Dark brown grey, silty clay, firm, frequent small to large sub-angular stones and occasional rooting	>7	1.36	0.33
6	607	603	fill	Secondary Fill	Mid orange brown, silty clay, firm, occasional small rounded pebbles and roots	>7	1.45	0.07
7	700		layer	Ploughsoil	Dark grey brown, silty clay, friable	50	2	0.2
7	701		layer	Subsoil	Mid grey brown, sandy clay, moderately compact with occasional limestone	50	2	0.1
7	702		layer	Natural	Mid yellow brown, sandy clay, moderately compact with occasional limestone and flint	50	2	
8	800		layer	Ploughsoil	Dark grey brown, silty clay, friable	50	2	0.2
8	801		layer	Subsoil	Mid grey brown, sandy clay, moderately compact with occasional limestone	50	2	0.2
8	802		layer	Natural	Mid yellow and mid red brown, sandy clay, moderately compact with occasional gravelly patches	50	2	
8	803		cut	Ditch	Linear NW-SE. Steep edges with concave base	2	1.3	0.6
8	804	803	fill	Secondary Fill	Dark brown, silty clay, firm, frequent charcoal flecks and occasional stones	2	1.17	0.5
8	805	803	fill	Tertiary Fill	Mid red brown, sandy silt, friable, rare small stones	2	1.3	0.12
9	900		layer	Ploughsoil	Dark grey brown, silty clay, friable	50	2	0.2
9	901		layer	Subsoil	Mid grey brown, sandy clay, moderately compact with occasional limestone	50	2	0.2
9	902		layer	Natural	Mid yellow brown and mid red brown, sandy clay, moderately	50	2	

					compact with occasional limestone and flint			
9	903		cut	Ditch	Linear N-S. Steep edges with concave base	>2	1.73	0.52
9	904	903	fill	Secondary Fill	Dark grey brown, silty clay, firm, occasional small to large sub-rounded stones	>2	1.73	0.52
10	1000		layer	Ploughsoil	Dark grey brown, silty clay, friable	50	2	0.25
10	1001		layer	Subsoil	Mid grey brown, sandy clay, moderately compact with occasional limestone	50	2	0.15
10	1002		layer	Natural	Mid red brown, sandy clay, compact with occasional limestone and flint	50	2	
11	1100		layer	Ploughsoil	Dark grey brown, silty clay, friable	50	2	0.2
11	1101		layer	Subsoil	Mid grey brown, sandy clay, moderately compact with occasional roots and limestone	50	2	0.09
11	1102		layer	Natural	Light grey, silty clay, firm with degraded limestone	50	2	
12	1200		layer	Ploughsoil	Dark grey brown, silty clay, friable	50	2	0.31
12	1201		layer	Natural	Light yellow brown, silty clay with darker patches throughout, compact.	50	2	
12	1202		cut	Pit	Circular in plan. Gradual edges with concave base	>1.14	0.92	0.2
12	1203	1202	fill	Other Fill	Mid yellow brown, chalky clay, firm, frequent chalk flecks	>1.14	0.45	0.09
12	1204	1202	fill	Other Fill	Light brown yellow, chalky clay, firm, occasional chalk flecks	>1.14	0.92	0.13
12	1205	1202	fill	Other Fill	Light yellow grey, silty clay, firm, rare small angular stones	>1.14	0.7	0.1
12	1206		unexcavated feature	Pit	Circular in plan. Mid brown grey, silty clay, firm	1.62	1.11	
12	1207		void					
12	1208		unexcavated feature	Ditch	Linear NW-SE in plan. Mid brown grey, chalky clay, compact	>2	0.5	
12	1209		void					
12	1210		unexcavated feature	Pit	Circular in plan. Mid brown grey, chalky clay, firm	0.4	0.4	
12	1211		void					
12	1212		cut	Pit	Circular in plan. Gradual edges with concave base	1.9	0.73	0.14
12	1213	1212	fill	Other Fill	Light brown grey, silty clay, friable.	1.9	0.73	0.14
12	1214		cut	Pit	Circular in plan. Gradual edges with concave base		0.8	0.34
12	1215	1214	fill	Other Fill	Dark grey brown, silty clay, firm	0.8	0.8	0.58
12	1216		unexcavated feature	Pit	Circular in plan. Mid grey brown, silty clay, firm		0.52	
12	1217		void					
12	1218		cut	Ditch	Linear N-S. Gradual sloping edges with concave base	>1	0.8	0.27
12	1219	1218	fill	Other Fill	Mid grey brown, silty clay, firm	>1	0.8	0.27
12	1220		unexcavated feature	Pit	Circular in plan. Mid grey brown, silty clay, firm		0.56	
12	1221	1214	fill	Other Fill	Dark greyish brown deposit. Relatively firm clay., no finds		0.5	0.12
13	1300		layer	Ploughsoil	Dark grey brown, silty clay, friable	50	2	0.38
13	1301		layer	Natural	Light brown yellow, silty clay, friable	50	2	
13	1302		void					
13	1303		void					

13	1304		cut	Ditch	Linear NW-SE. Gentle sloping edges with concave base	2.5	1.26	0.24
13	1305	1304	fill	Other Fill	Mid brown orange, silty clay, compact, occasional small-medium sub-angular stones	2.3	0.82	0.12
13	1306	1304	fill	Other Fill	Dark brown, silty clay, friable, frequent shell and sub-angular small stones	2.3	1.26	0.12
13	1307		cut	Ditch	Curvilinear NE-SW. Fairly steep edges with concave base	>2.5	0.46	0.16
13	1308	1307	fill	Secondary Fill	Dark grey brown, silty clay, friable, occasional angular stones and charcoal flecks	>2.5	0.46	0.16
13	1309		cut	Ditch	Linear NE-SW. Fairly gentle edges with concave base	>1.1	0.42	0.06
13	1310	1309	fill	Secondary Fill	Mid grey brown, silty clay, friable, occasional small angular stones	>1.1	0.42	0.06
13	1311		layer	Floor Surface	Potential stone surface. Mid brown grey, silty clay, friable.	2	1.5	0.08
13	1312		layer	Other Layer	Large spread. Mid orange brown, silty clay, friable	>2	0.6	0.2
13	1313		void					
13	1314		cut	Pit	Circular in plan. Steep sides with concave base	0.54	0.55	0.3
13	1315	1314	fill	Other Fill	Mid grey brown, silty clay, firm, occasional sub-rounded stones	0.54	0.55	0.3
13	1316		cut	Ditch	Linear E-W. Steep edges with flat base	>1	0.98	0.44
13	1317	1316	fill	Other Fill	Mid grey brown, silty clay, firm, occasional sub-rounded stones	>1	0.98	0.44
14	1400		layer	Ploughsoil	Dark grey brown, silty clay, friable	50	1.8	0.37
14	1401		layer	Natural	Light brown yellow, silty clay, compact	50	1.8	
14	1402		cut	Ditch	Linear NE-SW. Fairly steep edges with concave base	>1	0.64	0.27
14	1403	1402	fill	Deliberate Backfill	Dark grey brown, silty clay, friable, occasional sub-angular stones	>1	0.64	0.27
15	1500		layer	Ploughsoil	Dark grey brown, silty clay, friable	50	2	0.28
15	1501		layer	Natural	Light brown yellow, silty clay, compact	50	1.8	
15	1502		cut	Pit	Circular in plan. Gradual NW edge, SW edge begins gradual, becoming steep via a sharp break of slope. Flat base.	>1.8	1.64	0.17
15	1503	1502	fill	Other Fill	Dark grey brown silty very fine clay. Occasional chalk.	>1.8	1.64	0.17
15	1504		cut	Pit	Circular in plan. Steep edges with concave base	0.98	0.66	0.25
15	1505	1504	fill	Other Fill	Mid brown grey, silty clay, friable, occasional charcoal flecks	0.98	0.66	0.25
15	1506		cut	Ditch	Linear E-W. Steep edges with concave base	>1	1.96	0.66
15	1507	1506	fill	Other Fill	Mid yellow brown, clayey silt, firm with occasional redeposited natural. Occasional medium sub-rounded stones and rare chalk flecks	>1	1.94	0.55
15	1508	1506	fill	Other Fill	Dark brown grey, silty clay, firm. Occasional medium angular stones	>1	1.96	0.55
16	1600		layer	Ploughsoil	Dark grey brown, silty clay, friable	50	2	0.35
16	1601		layer	Natural	Light brown yellow, silty clay, compact	50	2	
16	1602		cut	Modern	Modern linear NW-SE. Gentle slopes with concave base. Modern pipe at the bottom	>1	4	0.48
16	1603	1602	fill	Deliberate Backfill	Mid brown grey, silty clay, friable. Frequent charcoal deposits.	>1	4	0.4

17	1700		layer	Ploughsoil	Dark grey brown, silty clay, friable	50	2	0.2
17	1701		layer	Subsoil	Mid grey brown, sandy clay, moderately compact with frequent limestone	50	2	0.3
17	1702		layer	Natural	Light grey, firm, gravelly with occasional mid reddish brown sandy clay compact patches	50	2	
17	1703		void					
17	1704		void					
18	1800		layer	Ploughsoil	Dark grey brown, silty clay, friable	50	2	0.2
18	1801		layer	Subsoil	Mid grey brown, sandy clay, moderately compact with frequent limestone	50	2	0.15
18	1802		layer	Natural	Light grey, sandy silt, moderately compact with frequent limestone and occasional flint nodules	50	2	
18	1803		cut	Natural Feature	Tested and proved to be natural		2	
19	1900		layer	Ploughsoil	Dark grey brown, silty clay, friable	50	2	0.2
19	1901		layer	Subsoil	Mid grey brown, sandy clay, moderately compact with occasional limestone	50	2	0.25
19	1902		layer	Natural	Mid yellow and red brown, sandy clay, firm, with occasional limestone	50	2	
20	2000		layer	Ploughsoil	Dark grey brown, silty clay, friable	50	2	0.2
20	2001		layer	Subsoil	Mid grey brown, sandy clay, moderately compact with frequent limestone	50	2	0.15
20	2002		layer	Natural	Light grey, firm, silty clay with gravel	50	2	
20	2003		cut	Natural Feature	Tested and proved to be natural. Photographed and not drawn			
20	2004	2003	fill	Other Fill	Mid grey brown silty clay, some gravel			
21	2100		layer	Ploughsoil	Dark grey brown, silty clay, friable	50	2	0.2
21	2101		layer	Subsoil	Light grey brown, sandy silt, moderately gravelly	50	2	0.15
21	2102		layer	Natural	Light grey, firm, silty clay with gravel	50	2	
22	2200		layer	Ploughsoil	Dark grey brown, silty clay, friable	50	2	0.2
22	2201		layer	Subsoil	Mid grey brown, sandy clay, moderately compact with occasional limestone	50	2	0.2
22	2202		layer	Natural	Mid yellow brown, sandy clay, moderately compact with frequent limestone and flint nodules	50	2	
23	2300		layer	Ploughsoil	Dark grey brown, silty clay, friable	50	2	0.2
23	2301		layer	Subsoil	Mid grey brown, sandy clay, moderately compact with limestone inclusions	50	2	0.1
23	2302		layer	Colluvial Layer	Mid red brown, sandy silt, with fine limestone	50	2	0.4
23	2303		layer	Natural	Light grey, firm degraded limestone, with mid red brown sandy silt patches	50	2	
23	2304		cut	Natural Feature	Linear NE-SW. Sloping edges with flat base	>1	0.55	0.22
23	2305	2304	fill	Other Fill	Mid red brown, sandy clay, firm, occasional small angular stones	>1	0.55	0.22
23	2306		cut	Natural Feature	Linear NE-SW in plan. Irregular edges with concave base	>1	0.35	0.45
23	2307	2306	fill	Other Fill	Mid red brown, sandy clay, friable, occasional small angular stones	>1		
23	2308		cut	Ditch	Linear E-W. Gentle slopes with concave base	>1	1.69	0.42

23	2309	2308	fill	Primary Fill	Light grey, sandy clay, soft	>1	0.96	0.2
23	2310	2308	fill	Secondary Fill	Dark grey, sandy clay, soft, small rocks	>1	1.38	0.14
23	2311	2308	fill	Secondary Fill	Mid orange, sandy silt, soft, small rocks and shells	>1	1.64	0.2
23	2312		void			>1		
23	2313		cut	Ditch	Linear E-W. Steep sides with a flat base	>1	1	0.8
23	2314	2313	fill	Secondary Fill	Light brown grey, sandy silt, soft, occasional small pebbles and shells	>1	1	0.8
23	2315		cut	Ditch	Linear E-W. Gentle slopes with a flat base	>1	1.84	0.48
23	2316	2315	fill	Secondary Fill	Light grey white, sandy silt, firm, occasional small rocks	>1	1.84	0.48
23	2317		cut	Ditch	Linear E-W. Steep slopes with a concave base	>1	2.4	0.82
23	2318	2317	fill	Deliberate Backfill	Light brown grey, sandy silt, firm, occasional small rocks and shells	>1	1	0.2
23	2319	2317	fill	Deliberate Backfill	Dark grey, sandy silt, soft, occasional small rocks	>1	1.78	0.28
23	2320	2317	fill	Secondary Fill	Light brown grey, sandy silt, soft, small rocks and shells	>1	1.5	0.3
23	2321	2317	fill	Secondary Fill	Light brown orange, sandy silt, soft, small rocks	>1	1.94	0.26
24	2400		layer	Ploughsoil	Dark grey brown, silty clay, friable	50	2	0.2
24	2401		layer	Subsoil	Mid grey brown, sandy clay, moderately compact	50	2	0.15
24	2402		layer	Natural	Light grey, silty clay, firm, degraded limestone	50	2	
25	2500		layer	Ploughsoil	Dark grey brown, silty clay, friable	50	2	0.2
25	2501		layer	Subsoil	Mid grey brown, sandy clay, moderately compact with frequent fine limestone	50	2	0.1
25	2502		layer	Natural	Light grey, silty clay, firm with degraded limestone	50	2	
25	2503		cut	Ditch	Linear NE-SW. Steep sides with a concave base	>1	3	1.05
25	2504	2503	fill	Other Fill	Mid yellow grey brown, silty clay, friable, some stones	>1	0.95	0.45
25	2505	2503	fill	Other Fill	Mid red brown, silty clay, friable with some small stones	>1	0.45	0.2
25	2506	2503	fill	Other Fill	Mid grey brown, silty clay, friable with frequent stones	>1	3	0.75
25	2507		void					
25	2508	2503	fill	Other Fill	Mid grey brown, silty clay, friable with infrequent stones	>1	2.3	0.3
25	2509	2503	fill	Other Fill	Mixed light yellow brown and mid grey brown, silty clay, friable with infrequent stones	>1	2.2	0.2
25	2510		cut	Ditch	Linear NE-SW. Moderate to steep edges with concave base	>1	3.6	0.94
25	2511	2510	fill	Other Fill	Mid yellow brown, firm, silty clay with frequent small and medium sub angular stones.		2.4	0.4
25	2512	2510	fill	Other Fill	Mid grey brown, firm, silty clay. Occasional small sub angular stones and rare charcoal flecks		3.6	0.45
25	2513	2510	fill	Other Fill	Mid orange brown, firm, silty clay. Occasional small and medium sub angular stones and charcoal flecks		2	0.37
26	2600		layer	Ploughsoil	Dark grey brown, silty clay, friable	50	2	0.2
26	2601		layer	Subsoil	Mid grey brown, sandy clay, moderately compact	50	2	0.14
26	2602		layer	Natural	Light grey, silty clay, firm with degraded limestone	50	2	

27	2700		layer	Ploughsoil	Dark grey brown, silty clay, friable	50	2	0.2
27	2701		layer	Subsoil	Mid grey brown, sandy clay, moderately compact with frequent limestone	50	2	0.1
27	2702		layer	Natural	Mid grey brown, sandy clay, moderately compact with frequent limestone	50	2	
27	2703		cut	Ditch	Linear N-S. Moderate slopes with concave base	>2.2	3.68	0.65
27	2704	2703	fill	Other Fill	Mid grey brown, silty clay, loose, rare small pebbles	>2.2	0.84	0.09
27	2705	2703	fill	Other Fill	Mid brown grey, silty clay, loose, frequent large angular stones	>2.2	1.55	0.2
27	2706	2703	fill	Other Fill	Light brown, silty clay, loose, occasional medium rounded pebbles	>2.2	2.48	0.18
27	2707	2703	fill	Other Fill	Mid grey brown, silty clay, compact, occasional medium rounded pebbles	>2.2	3.68	0.23
27	2708		cut	Ditch	Linear NW-SE. Gradual edges with a concaved base	>1	2.61	0.4
27	2709	2708	fill	Other Fill	Light brown, clayey sand, friable, frequent small angular stones		2.61	0.4
27	2710	2708	fill	Other Fill	Light orange brown, clayey sand, loose. Rare angular small stones		1.4	0.2
28	2800		layer	Ploughsoil	Dark grey brown, silty clay, friable	50	2	0.2
28	2801		layer	Subsoil	Dark brown, sandy clay, moderately compact with occasional limestone	50	2	0.2
28	2802		layer	Natural	Mid yellow brown, sandy silt, moderately compact with occasional limestone and flint nodules	50	2	
29	2900		layer	Ploughsoil	Dark grey brown, silty clay, friable	50	2	0.2
29	2901		layer	Subsoil	Dark brown, sandy clay, moderately compact with occasional limestone	50	2	0.2
29	2902		layer	Natural	Mid yellow brown, sandy silt, moderately compact with occasional limestone and flint	50	2	
30	3000		layer	Ploughsoil	Dark grey brown, silty clay, friable	50	2	0.2
30	3001		layer	Subsoil	Mid grey brown, sandy clay, moderately compact with occasional limestone	50	2	0.1
30	3002		layer	Colluvial Layer	Mid yellow brown, sandy silt, moderately compact with occasional limestone and flint	50	2	0.2
30	3003		layer	Natural	Light grey, silty clay, firm with degraded limestone	50	2	
30	3004		cut	Ditch	Linear NW-SE. Gradual slopes with concave base	>1	1.65	0.45
30	3005	3004	fill	Other Fill	Mid yellow brown, sandy silt, friable, rare stones	>1	0.9	0.43
30	3006	3004	fill	Secondary Fill	Mid grey brown, sandy silt, firm, rare flecks of charcoal and stones	>1	1.3	0.45
30	3007	3004	fill	Secondary Fill	Mid yellow grey, sandy silt, compact, occasional small stones and shell	>1	0.55	0.25
31	3100		layer	Ploughsoil	Dark grey brown, silty clay, friable	50	2	0.2
31	3101		layer	Subsoil	Dark brown, sandy clay, moderately compact with occasional limestone	50	2	0.2
31	3102		layer	Natural	Mid yellow brown, sandy silt, moderately compact with occasional limestone and flint	50	2	
31	3103		cut	Ditch	Linear E-W. Steep slopes with flat base	>1	1	0.44

31	3104	3103	fill	Secondary Fill	Mid grey brown, silty sand, loose, occasional pebbles	>1	1	0.44
31	3105		cut	Ditch	Linear E-W. Gentle slopes with concave base	>1	0.47	0.35
31	3106	3105	fill	Secondary Fill	Mid grey brown, silty sand, loose, rare small pebbles	>1	0.47	0.35
32	3200		layer	Ploughsoil	Dark grey brown, silty clay, friable	50	2	0.2
32	3201		layer	Subsoil	Mid grey brown, sandy clay, moderately compact	50	2	0.1
32	3202		layer	Colluvial Layer	Mid yellow brown, sandy silt, moderately compact with occasional limestone and flint	50	2	0.2
32	3203		layer	Natural	Light grey, silty clay, firm with degraded limestone	50	2	
32	3204		cut	Pit	Oval in plan. Moderate slopes with a flat base	1.25	1.05	0.18
32	3205	3204	fill	Primary Fill	Mid grey black, silty clay, loose, rare small pebbles	1.25	1.05	0.18
32	3206		cut	Pit	Oval in plan. Moderate slopes with concave base		1.88	0.45
32	3207	3206	fill	Primary Fill	Dark grey brown, silty clay, loose, frequent small pebbles		1.88	0.45
32	3208		cut	Pit	Oval in plan. Moderate slopes with flat base		1.48	0.2
32	3209	3208	fill	Primary Fill	Dark grey brown, silty clay, loose, rare small pebbles		1.48	0.2
33	3300		layer	Ploughsoil	Dark grey brown, silty clay, friable	50	2	0.2
33	3301		layer	Subsoil	Mid grey brown, sandy silt, loose	50	2	0.15
33	3302		layer	Natural	Mid yellow brown, sandy clay, compact with occasional flint and limestone	50	2	
34	3400		layer	Ploughsoil	Dark grey brown, silty clay, friable	50	2	0.25
34	3401		layer	Natural	Mid yellow brown, sandy clay, moderately compact with occasional limestone and flint	50	2	
34	3402		cut	Ditch	Linear N-S. Gradual slopes with concave base	>1	0.67	0.08
34	3403	3402	fill	Other Fill	Dark grey brown, silty sand, loose with frequent sub-angular stone inclusions	>1	0.67	0.08
35	3500		layer	Ploughsoil	Dark grey brown, silty clay, friable	50	2	0.2
35	3501		layer	Subsoil	Mid grey brown, sandy silt, moderately compact	50	2	0.15
35	3502		layer	Natural	Mid yellow brown, sandy clay, moderately compact with occasional limestone and flint	50	2	
35	3503		cut	Ditch	Linear NW-SE. Gradual slopes with concave base	>1	1.68	0.72
35	3504	3503	fill	Other Fill	Mid orange brown, silty sand, friable, occasional small angular stones		1.68	0.72
35	3505	3503	fill	Other Fill	Dark grey brown, silty sand, friable, rare medium rounded stones		0.66	0.2
35	3506		cut	Ditch	Linear NW-SE. Gradual slopes with a flat base	>1	2	0.6
35	3507	3506	fill	Other Fill	Mid orange brown, silty sand, friable, occasional medium rounded stones		1.6	0.22
35	3508	3506	fill	Other Fill	Dark grey brown, silty sand, friable, occasional small stones and rare medium stones		1.66	0.22
35	3509	3506	fill	Other Fill	Light orange, silty sand, loose, rare medium stones and occasional small stones		1.98	0.2
36	3600		layer	Ploughsoil	Dark grey brown, silty clay, friable	50	2	0.2

36	3601		layer	Subsoil	Mid grey brown, sandy silt, moderately compact	50	2	0.2
36	3602		layer	Natural	Mid yellow brown, sandy clay, moderately compact with occasional limestone and flint	50	2	
37	3700		layer	Ploughsoil	Dark grey brown, silty clay, friable	50	2	0.2
37	3701		layer	Subsoil	Mid grey brown, sandy clay, moderately compact	50	2	0.2
37	3702		layer	Natural	Mid yellow brown, sandy silt, moderately compact with occasional limestone and flint	50	2	
38	3800		layer	Ploughsoil	Dark grey brown, silty clay, friable	50	2	0.2
38	3801		layer	Subsoil	Mid grey brown, sandy clay, moderately compact	50	2	0.2
38	3802		layer	Natural	Mid yellow brown, sandy clay, moderately compact with occasional limestone and flint	50	2	
39	3900		layer	Ploughsoil	Dark grey brown, silty clay, friable	50	2	0.2
39	3901		layer	Subsoil	Mid grey brown, sandy clay, moderately compact	50	2	0.2
39	3902		layer	Natural	Mid yellow brown, sandy silt, moderately compact with occasional limestone and flint	50	2	
40	4000		layer	Ploughsoil	Dark grey brown, silty clay, friable	50	2	0.25
40	4001		layer	Subsoil	Mid grey brown, sandy silt, moderately compact	50	2	0.15
40	4002		layer	Natural	Mid red brown, sandy clay, compact with occasional limestone and flint	50	2	
40	4003		cut	Ditch	Linear N-S. Gentle slopes with concave base	>1	2.5	0.22
40	4004	4003	fill	Other Fill	Light grey brown, sandy silt, loose with occasional small rounded stones	>1	2.5	0.22
40	4005		cut	Ditch	Linear N-S. Gentle slopes with concave base	>1	1.46	0.14
40	4006	4005	fill	Other Fill	Light grey brown, sandy silt, loose, occasional small rounded stones	>1	1.46	0.14
40	4007		cut	Pit	Circular in plan. Vertical sides with irregular base	0.96	1.54	0.56
40	4008	4007	fill	Other Fill	Dark grey brown, silty sand, loose. Frequent stone and flint	0.96	1.54	0.56
41	4100		layer	Ploughsoil	Dark grey brown, silty clay, friable	50	2	0.15
41	4101		layer	Subsoil	Mid grey brown, sandy silt, moderately compact with frequent stones	50	2	0.15
41	4102		layer	Natural	Light grey, silty clay, firm with gravel patches	50	2	
42	4200		layer	Ploughsoil	Dark grey brown, silty clay, friable	50	2	0.2
42	4201		layer	Subsoil	Mid grey brown, sandy silt, moderately compact with frequent limestone	50	2	0.25
42	4202		layer	Natural	Light brown yellow with orange patches, clayey sand, friable, frequent pebbles and flint	50	2	
42	4203		cut	Ring Ditch	Curvilinear ring ditch. NE-SW. Steep edges with concave base	>2	2.97	0.75
42	4204	4203	fill	Secondary Fill	Mid yellow brown, sandy clay, loose, occasional rounded stones	>2	0.55	0.17
42	4205	4203	fill	Secondary Fill	Mid orange brown, silty clay, friable. Occasional rounded and angular stones	>2	1.07	0.12
42	4206	4203	fill	Secondary Fill	Mid yellow grey, silty clay, friable, frequent small gravel	>2	1.59	0.22
42	4207	4203	fill	Secondary Fill	Mid grey brown, sandy silt, compact, occasional small rounded stones	>2	1.98	0.3

42	4208		cut	Ring Ditch	Curvilinear in plan. NE-SW. Steep edges with concave- almost v shaped base	>2	2.47	1.06
42	4209	4208	fill	Other Fill	Mid brown orange, clayey silt, friable, frequent small pebble inclusions	>2	0.13	0.12
42	4210	4208	fill	Other Fill	Mid brown orange, clayey silt, friable, frequent small pebble inclusions	>2	0.17	0.17
42	4211	4208	fill	Other Fill	Light yellow orange, clayey silt, friable, frequent small pebbles and occasional large flints and stones	>2	0.34	0.23
42	4212	4208	fill	Other Fill	Mid yellow orange, clayey silt, friable, frequent large rounded stones and sub angular flint	>2	0.7	0.25
42	4213	4208	fill	Secondary Fill	Dark orange brown, silty clay, friable, frequent small pebbles and gravel	>2	1.27	0.1
42	4214	4208	fill	Other Fill	Mid red brown, silty clay, compact, occasional large rounded stones and angular flint	>2	2.34	0.49
42	4215	4208	fill	Secondary Fill	Light brown yellow, silty clay, friable, occasional small gravel	>2	0.13	0.17
42	4216		cut	Ring Gully	Curvilinear in plan. NE-SW. Steep edges with concave base	>2	1.5	0.5
42	4217	4216	fill	Secondary Fill	Mid brown grey, silty clay, friable, occasional large rounded stones and flint	>2	1.5	0.5
42	4218		cut	Ring Gully	Curvilinear in plan. NE-SW. Fairly steep edges with concave base	>1.5	0.39	0.4
42	4219	4218	fill	Secondary Fill	Mid grey brown, silty clay, friable, rare small rounded stones	>1.5	0.39	0.4
42	4220		cut	Ring Ditch	Curvilinear in plan. NE-SW. Steep edges with concave base	>1	3.34	0.96
42	4221	4220	fill	Other Fill	Light brown yellow, sandy gravel, friable	>1	1.3	0.12
42	4222	4220	fill	Other Fill	Mid yellow brown, silty gravel, loose.	>1	1.58	0.18
42	4223	4220	fill	Other Fill	Mid red brown, silty sand, friable, small pebbles	>1	1.02	0.15
42	4224	4220	fill	Other Fill	Mid red brown, silty sand, friable, rare small pebbles	>1	0.89	0.1
42	4225	4220	fill	Other Fill	Mid brown, silty sand, friable, occasional stones	>1	3.12	0.26
42	4226	4220	fill	Other Fill	Dark grey, silty sand, friable, occasional charcoal flecks	>1	1.54	0.12
42	4227	4220	fill	Other Fill	Mid brown, silty sand, friable, rare flecks of charcoal	>1	2.94	0.28
42	4228		cut	Tree Throw	Irregular in plan. Irregular edges and base	>1.7	1.07	0.38
42	4229		cut	Ditch	Curvilinear in plan. NE-SW. Steep concave sides and a flat base.	>2	0.46	0.26
42	4230	4229	fill	Other Fill	Mid grey brown, sandy silt, compact, rare small stones	>2	0.46	0.26
42	4231		cut	Ditch	Linear NE-SW. Steep edges with concave base	>2	0.55	0.35
42	4232	4231	fill	Secondary Fill	Light orange brown, silty clay, friable, frequent small rounded pebbles	>2	0.55	0.35
42	4233		cut	Ditch	Linear NE-SW. Steep edges with concave base	>2	0.57	0.46
42	4234	4233	fill	Secondary Fill	Light orange brown, silty clay, friable, frequent small-medium rounded pebbles	>2	0.57	0.46
42	4235		cut	Ring Ditch	Curvilinear in plan. NE-SW. Steep edges with concave base	>2	2.58	0.88
42	4236	4235	fill	Other Fill	Light yellow brown, clayey silt, friable, frequent flint and stones	>2	0.5	0.24
42	4237	4235	fill	Other Fill	Light yellow, clayey silt, friable, frequent small gravel stones	>2	0.09	0.16

42	4238	4235	fill	Secondary Fill	Light grey brown, clayey silt, friable, occasional large rounded stones and flint	>2	0.82	0.21
42	4239	4235	fill	Secondary Fill	Mid orange brown, clayey silt, compact, frequent large rounded stones and flint	>2	1.41	0.16
42	4240	4235	fill	Secondary Fill	Mid grey brown, silty clay, compact, frequent medium-large rounded stones and flint	>2	2.58	0.34
42	4241		layer	Other Layer	Dark red brown, clayey silt, friable, frequent small-large rounded stones and flint	>2	0.9	0.24
42	4242		cut	Pit	Circular in plan. Steep edges with concave base	>0.6	1.44	0.4
42	4243	4242	fill	Secondary Fill	Dark grey brown, silty clay, friable, frequent large rounded stones	>0.6	1.44	0.4
42	4244		cut	Posthole	Circular in plan. Steep edges with concave base	0.15	0.41	0.17
42	4245	4244	fill	Secondary Fill	Light grey yellow, silty clay, friable, frequent small rounded pebbles	0.15	0.41	0.17
42	4246		cut	Ditch	Curvilinear in plan. NE-SW. Fairly steep edges with concave base	>1.8	0.53	0.25
42	4247	4246	fill	Secondary Fill	Light grey brown, silty clay, friable, frequent small rounded pebbles	>1.8	0.53	0.25
42	4248	4228	fill	Other Fill	Light brown, silty sand, friable.		1.07	0.38
42	4249		cut	Pit	Circular in plan. Steep edges with concave base	>0.7		
42	4250	4249	fill	Deliberate Backfill	Dark brown grey, silty clay, loose, frequent charcoal flecks and rounded stones	>0.7		
43	4300		layer	Ploughsoil	Dark grey brown, silty clay, friable	50	2	0.2
43	4301		layer	Subsoil	Mid grey brown, sandy silt, friable with frequent limestone and flint	50	2	0.15
43	4302		layer	Natural	Light grey, silty clay, firm with gravel patches	50	2	
44	4400		layer	Ploughsoil	Dark grey brown, silty clay, friable	50	2	0.15
44	4401		layer	Subsoil	Mid grey brown, sandy silt, friable with frequent stones	50	2	0.15
44	4402		layer	Natural	Light grey, silty clay with gravel, moderately compact	50	2	
44	4403		cut	Pit	Circular in plan. Steep edges with concave base	1.28	1.28	0.8
44	4404	4403	fill	Other Fill	Mid grey brown, silty sand, loose, frequent small stones	1.28	1.28	0.8
44	4405		cut	Pit	Circular in plan. Gradual slopes with a concave base	0.65	0.9	0.22
44	4406	4405	fill	Other Fill	Mid brown, silty clay, friable, occasional small stones	0.65	0.9	0.22
44	4407		cut	Pit	Sub circular in plan. Steep concave sides with rounded base.	0.7	0.63	0.3
44	4408	4407	fill	Other Fill	Dark grey brown, sandy clay, loose. Occasional small - medium rounded stone. Rooting present.	0.7	0.63	0.3
44	4409		cut	Pit	Sub circular in plan. Sloping/steep concave sides, slightly uneven base.	1	0.8	0.32
44	4410	4409	fill	Other Fill	Dark grey brown, sandy clay, loose. Very regular sub angular & rounded stones. Rooting present.	1	0.8	32
44	4411		cut	Pit	Oval in plan. Fairly steep edges with concave base	0.77	0.43	0.21
44	4412	4411	fill	Secondary Fill	Mid grey brown, silty clay, friable, occasional stones	0.77	0.43	0.21
45	4500		layer	Ploughsoil	Dark grey brown, silty clay, friable	50	2	0.2
45	4501		layer	Subsoil	Mid grey brown, sandy clay, moderately compact with frequent stones	50	2	0.15

45	4502		layer	Natural	Mid blue grey, silty clay, moderately compact	50	2	
45	4503		cut	Quarry	Sub-circular in plan. Gentle sloping sides, flat base.	1.1	1	0.36
45	4504	4503	fill	Deliberate Backfill	Dark grey black, silty clay, friable.	1.1	1	0.36
46	4600		layer	Ploughsoil	Mid grey brown, silty clay, friable	50	2	0.36
46	4601		layer	Natural	Light brown yellow with red patches, silty clay, friable, frequent limestones	50	2	
47	4700		layer	Ploughsoil	Mid grey brown, silty clay, friable	50	2	0.34
47	4701		layer	Natural	Light brown yellow with red patches, silty clay, friable, frequent limestones	50	2	
48	4800		layer	Ploughsoil	Mid grey brown, silty clay, friable	50	2	0.29
48	4801		layer	Natural	Light brown yellow with red patches, silty clay, friable, frequent limestones	50	2	
49	4900		layer	Ploughsoil	Mid grey brown, silty clay, friable	50	2	0.3
49	4901		layer	Natural	Light brown yellow with red patches, silty clay, friable, frequent limestones	50	2	
50	5000		layer	Ploughsoil	Mid grey brown, silty clay, friable	50	2	
50	5001		layer	Natural	Light brown yellow with red patches, silty clay, friable, frequent limestones	50	2	
51	5100		layer	Ploughsoil	Mid grey brown, silty clay, friable	50	2	0.31
51	5101		layer	Natural	Light brown yellow with red patches, silty clay, friable, frequent limestones	50	2	
52	5200		layer	Ploughsoil	Mid grey brown, silty clay, friable	50	2	0.31
52	5201		layer	Natural	Light brown yellow with red patches, silty clay, friable, frequent limestones	50	2	
53	5300		layer	Ploughsoil	Mid grey brown, silty clay, friable	50	2	0.34
53	5301		layer	Natural	Light brown yellow with red patches, silty clay, friable, frequent limestones	50	2	
54	5400		layer	Ploughsoil	Mid grey brown, silty clay, friable	50	2	
54	5401		layer	Natural	Light brown yellow with red patches, silty clay, friable, frequent limestones	50	2	
55	5500		layer	Ploughsoil	Mid grey brown, silty clay, friable	50	2	0.32
55	5501		layer	Natural	Light brown yellow with red patches, silty clay, friable, frequent limestones	50	2	
56	5600		layer	Ploughsoil	Mid grey brown, silty clay, friable	50	2	0.29
56	5601		layer	Natural	Light brown yellow with red patches, silty clay, friable, frequent limestones	50	2	
56	5602		cut	Pit	Circular in plan. Fairly steep edges with flat base	1.7	1.1	0.32
56	5603	5602	fill	Secondary Fill	Light grey brown, silty sand, soft, frequent small to medium rocks	1.7	1.1	0.32
57	5700		layer	Ploughsoil	Mid grey brown, silty clay, friable	50	2	0.32
57	5701		layer	Natural	Light brown yellow, silty clay, compact, occasional small rounded stones	50	2	
57	5702		layer	Other Layer	Mid grey brown, silty clay, soft, rare rounded stones	2.9	0.7	0.15
57	5703		cut	Pit	Rectangular in plan NW-SE. Steep edges with uneven base	2.9	0.7	0.5
57	5704	5703	fill	Secondary Fill	Mid red brown, sandy clay, loose, frequent stones	2.9	0.7	0.5

58	5800		layer	Ploughsoil	Mid grey brown, silty clay, friable	50	2	0.27
58	5801		layer	Natural	Light brown yellow, silty clay, compact, occasional small rounded stones	50	2	
59	5900		layer	Ploughsoil	Mid grey brown, silty clay, friable	50	2	0.28
59	5901		layer	Natural	Light brown yellow and red orange, silty clay, compact, bands of ironstone	50	2	
60	6000		layer	Ploughsoil	Mid grey brown, silty clay, friable	50	2	0.3
60	6001		layer	Natural	Light brown yellow and red orange, silty clay, compact, bands of ironstone	50	2	0.28
61	6100		layer	Ploughsoil	Mid grey brown, silty clay, friable	50	2	0.29
61	6101		layer	Natural	Light brown yellow and red orange, silty clay, compact, bands of ironstone	50	2	
62	6200		layer	Ploughsoil	Mid grey brown, silty clay, friable	50	2	0.3
62	6201		layer	Natural	Light brown yellow and red orange, silty clay, compact, bands of ironstone	50	2	
63	6300		layer	Ploughsoil	Mid grey brown, silty clay, friable	50	2	0.2
63	6301		layer	Subsoil	Mid yellow brown, silty clay, friable	50	2	0.12
63	6302		layer	Natural	Mid brown yellow, silty clay, compact, occasional stones	50	2	
63	6303		cut	Pit	Oval, steep sides, flat base	1	0.6	0.2
63	6304	6303	fill	Deliberate Backfill	Mid greyish brown, firm silt, frequent burnt limestone, moderate charcoal, moderate limestone	1.1	0.5	0.1
63	6305	6303	fill	Deliberate Backfill	Mid reddish brown, firm silt, moderate charcoal and limestone	1.1	0.7	0.2
63	6306		cut	Ditch	Linear, steep sides, concave base, n/s	>1	0.2	0.08
63	6307	6306	fill	Secondary Fill	Light reddish brown firm silt. Rare limestone inclusions and charcoal	>1	0.25	0.08
63	6308		cut	Ditch	Linear, gradual concave sides, concave base, n/s	>1	0.3	0.05
63	6309	6308	fill	Secondary Fill	Pale pinkish brown, soft silty clay.	>1	0.3	0.05
63	6310		cut	Pit	Oval shape, gradual concave sides, concave base	0.6	0.4	0.1
63	6311	6310	fill	Secondary Fill	Dark reddish brown, soft sandy clay. Occasional small limestone pieces	0.4	0.6	0.1
63	6312		cut	Pit	Sub circular feature, steep straight sides, concave base	0.64	0.27	0.17
63	6313	6312	fill	Deliberate Backfill	Mid brown, soft silty clay. Moderate stones (small)	0.2	0.27	0.17
63	6314	6312	fill	Deliberate Backfill	Mid reddish brown soft silty clay. Occasional stones (small) and charcoal	0.44	0.23	0.17
63	6315		cut	Pit	Sub rectangular, steep sides, irregular base	0.9	1.5	0.21
63	6316	6315	fill	Deliberate Backfill	Dark brownish red, friable sandy silt	0.9	1.5	0.21
64	6400		layer	Ploughsoil	Mid grey brown, silty clay, friable	50	2	0.2
64	6401		layer	Natural	Mid brown yellow, silty clay, friable	50	2	0.1
64	6402		layer	Natural	Mid brown yellow, silty clay, compact, frequent stones	50	2	
65	6500		layer	Ploughsoil	Mid grey brown, silty clay, friable	50	2	0.19
65	6501		layer	Subsoil	Mid yellow brown, silty clay, friable	50	2	0.1
65	6502		layer	Natural	Light brown white, silty chalk, firm, occasional stones	50	2	

65	6503		layer	Other Layer	Natural feature. Circular spring from bedrock causing blue grey silt on East Side of trench	1.1	1.1	
66	6600		layer	Ploughsoil	Mid grey brown, silty clay, friable	50	2	0.2
66	6601		layer	Subsoil	Mid yellow brown, silty clay, friable	50	2	0.14
66	6602		layer	Natural	Mid brown orange with white chalk patches, silty clay, compact, occasional stones	50	2	
67	6700		layer	Ploughsoil	Mid grey brown, silty clay, friable	50	2	0.2
67	6701		layer	Subsoil	Mid yellow brown, silty clay, friable	50	2	0.12
67	6702		layer	Natural	Mid brown white, silty chalk with black clay patches, firm, occasional stones	50	2	
67	6703		cut	Ditch	Linear ditch, curving sides, concave base see/w	>1	2	0.6
67	6704	6703	fill	Primary Fill	Dark greyish sandy clayey silt. Soft. Occasional chalk flecks	>1	0.36	0.1
67	6705	6703	fill	Primary Fill	Pale greyish white soft silty clay. Moderate chalk flecks	>1	0.7	0.04
67	6706	6703	fill	Secondary Fill	Pale orange loose sand. Occasional charcoal	>1	0.45	0.04
67	6707	6703	fill	Secondary Fill	Dark greyish brown firm sandy silt. Occasional chalk flecks and limestone pieces	>1	1	0.36
67	6708	6703	fill	Secondary Fill	Mid greyish brown, soft sandy clay. Occasional chalk flecks	>1	1.4	0.6
68	6800		layer	Ploughsoil	Mid grey brown, silty clay, friable	50	2	0.26
68	6801		layer	Natural	Mid brown white, silty chalk with red patches of clay, friable, occasional gravel	50	2	
69	6900		layer	Ploughsoil	Mid grey brown, silty clay, friable	50	2	0.3
69	6901		layer	Natural	Mid brown white with red clay patches, silty chalk, friable, occasional limestone	50	2	
69	6902		unexcavated feature	Ditch	Linear N-S. Fill is mid orange brown, clayey sand, friable, frequent pebbles and flint		2.8	
70	7000		layer	Ploughsoil	Mid grey brown, silty clay, friable	50	2	0.29
70	7001		layer	Natural	Mid brown white with red clay patches, silty chalk, friable, occasional limestone	50	2	
71	7100		layer	Ploughsoil	Mid grey brown, silty clay, friable	50	2	0.3
71	7101		layer	Natural	Mid brown white with red clay patches, silty chalk, friable, occasional limestones	50	2	
71	7102		cut	Ditch	Linear E-W. Steep edges with concave base	>1	2.55	1.12
71	7103	7102	fill	Secondary Fill	Mid white brown, sandy gravel, loose, frequent small-medium rocks	>1	2.55	0.62
71	7104	7102	fill	Secondary Fill	Mid brown, silty sand, loose, frequent small-medium rocks	>1	2.35	0.5
72	7200		layer	Ploughsoil	Mid grey brown, silty clay, friable			0.31
72	7201		layer	Natural	Mid brown white with red clay patches, silty chalk, friable, occasional limestone			
72	7202		cut	Ditch	Linear NW-SE. Steep edges with a concave base	>1	1.7	0.62
72	7203	7202	fill	Secondary Fill	Mid orange brown, silty chalk, friable. occasional small rounded stones	>1	0.25	0.06
72	7204	7202	fill	Secondary Fill	Dark brown grey, silty chalk, friable, frequent small-large rounded stones and flint, frequent roots	>1	1.7	0.57

72	7205		cut	Ditch	Linear NW-SE. Steep edges with concave base	>1	1.15	0.35
72	7206	7205	fill	Secondary Fill	Mid orange brown, silty chalk, compact, frequent small to large rounded stones and flint, occasional chalk flecks	>1	1.15	0.35
72	7207		cut	Quarry	Circular in plan. Steep edges with concave base	>1	3.4	1.24
72	7208	7207	fill	Secondary Fill	Dark grey brown, silty clay, friable, frequent small to large rounded stones	>1	1.89	0.53
72	7209	7207	fill	Secondary Fill	Mid brown grey, clayey sand, friable, frequent small to medium rounded stones	>1	3.2	0.47
72	7210	7207	fill	Secondary Fill	Light grey yellow, sandy clay, loose, frequent small pebbles and gravel	>1	1.24	0.07
72	7211	7207	fill	Secondary Fill	Mid grey brown, silty clay, firm, frequent small to large rounded stones	>1	3	0.3
72	7212	7207	fill	Deliberate Backfill	Mid orange red, silty clay, friable, frequent charcoal flecks and small to medium stones	>1	1.18	0.27
72	7213	7207	fill	Deliberate Backfill	Dark grey brown, silty clay, compact, frequent small to medium rounded stones, rare charcoal flecks	>1	2.97	0.2
72	7214	7207	fill	Secondary Fill	Light brown grey, sandy clay, friable, frequent small to large rounded stones and angular flint	>1	2.25	0.42
72	7215	7207	fill	Secondary Fill	Light grey brown, sandy clay, loose, frequent small to large rounded stones	>1	1.14	0.2
73	7300		layer	Ploughsoil	Mid grey brown, silty clay, friable	50	2	0.34
73	7301		layer	Subsoil	Mid red brown, silty clay, friable	50	2	0.12
73	7302		layer	Natural	Light white yellow with red clay patches, silty chalk, friable	50	2	
73	7303		cut	Pit	Trapezoidal in plan. Fairly gentle edges with irregular base	>1.7	1.05	0.3
73	7304	7303	fill	Secondary Fill	Mid red brown, silty clay, firm, rare small angular stones	>1.5	0.4	0.27
73	7305	7303	fill	Secondary Fill	Mid red brown, silty clay, compact, occasional rooting	>1.55	0.55	0.2
73	7306	7303	fill	Secondary Fill	Light red grey, silty clay, soft, rare sub-angular stones	>1.7	0.7	0.25
74	7400		layer	Ploughsoil	Mid grey brown, silty clay, friable	50	2	0.27
74	7401		layer	Natural	Mid brown white with red clay patches, silty chalk, friable, occasional limestone	50	2	
75	7500		layer	Ploughsoil	Mid grey brown, silty clay, friable	50	2	
75	7501		layer	Subsoil	Mid red brown, silty clay, friable	50	2	
75	7502		layer	Natural	Light brown white with yellow patches, silty clay, friable, occasional sub rounded stones	50	2	
75	7503		cut	Ditch	Linear N-S. Moderate slopes with uneven base	>2.9	0.92	0.14
75	7504	7503	fill	Primary Fill	Mid orange brown, sandy clay, soft, occasional small stones	>2.9	0.92	0.14
76	7600		layer	Ploughsoil	Mid grey brown, silty clay, friable	50	2	
76	7601		layer	Subsoil	Mid red brown, silty clay, friable	50	2	
76	7602		layer	Natural	Mid brown yellow, silty clay, compact, occasional gravel patches	50	2	
77	7700		layer	Ploughsoil	Mid grey brown, silty clay, friable	50	2	

77	7701		layer	Natural	Mid brown yellow, silty clay, compact with occasional light grey patches.	50	2	
78	7800		layer	Ploughsoil	Mid grey brown, silty clay, friable	50	2	
78	7801		layer	Natural	Mid brown yellow, silty clay, compact with orange patches	50	2	
79	7900		layer	Ploughsoil	Mid grey brown, silty clay, friable	50	2	
79	7901		layer	Natural	Light brown white, silty chalk, friable, occasional stones	50	2	
79	7902		cut	Ditch	Linear N-S. Fairly steep edges with concave base	2.3	1	0.2
79	7903	7902	fill	Secondary Fill	Light grey brown with red patches, sandy clay, firm, frequent angular stones	2.05	1	0.42
79	7904	7902	fill	Secondary Fill	Mid red brown, silty clay, friable, rare angular stones	2.3	1	0.32
80	8000		layer	Ploughsoil	Mid grey brown, silty clay, friable	50	2	
80	8001		layer	Subsoil	Mid red brown, silty clay, friable	50	2	
80	8002		layer	Natural	Light brown yellow with grey patches, silty clay, friable, frequent limestone	50	2	
81	8100		layer	Ploughsoil	Mid grey brown, silty clay, friable	50	2	
81	8101		layer	Subsoil	Mid red brown, silty clay, friable	50	2	
81	8102		layer	Natural	Light brown yellow with grey patches, silty clay, friable, frequent limestone	50	2	
81	8103		cut	Ditch	Linear NE-SW. Fairly steep slopes with concave base	>1	0.95	0.17
81	8104	8103	fill	Primary Fill	Mid grey brown, silty clay, firm, occasional sub-angular stones	>1	0.95	0.17
82	8200		layer	Ploughsoil	Mid grey brown, silty clay, friable	50	2	
82	8201		layer	Subsoil	Mid red brown, silty clay, friable	50	2	
82	8202		layer	Natural	Light brown yellow with grey patches, silty clay, compact, frequent limestone	50	2	
82	8203		unexcavated feature	Pond	light brownish grey silty clay with infrequent small qstone inclusions		7.4	
83	8300		layer	Ploughsoil	Mid grey brown, silty clay, friable	50	2	
83	8301		layer	Subsoil	Mid red brown, silty clay, friable	50	2	
83	8302		layer	Natural	Light brown yellow with grey patches, silty clay, compact, frequent limestone	50	2	
84	8400		layer	Ploughsoil	Mid grey brown, silty clay, friable	50	2	
84	8401		layer	Subsoil	Mid red brown, silty clay, friable	50	2	
84	8402		layer	Natural	Light brown yellow with grey patches, silty clay, compact, frequent limestone	50	2	
85	8500		layer	Ploughsoil	Mid grey brown, silty clay, friable	50	2	
85	8501		layer	Natural	Mid brown yellow, silty clay, friable, frequent stones	50	2	
86	8600		layer	Ploughsoil	Mid brown grey, silty clay, friable	50	2	0.28
86	8601		layer	Natural	Light brown yellow, silty clay, compact, occasional limestones	50	2	
86	8602		cut	Ditch	Linear NW-SE. Gentle slopes with concave base	>1	1.5	0.13
86	8603	8602	fill	Other Fill	Mid brown, sandy silt, loose, rare charcoal flecks	>1	1.5	0.13
87	8700		layer	Ploughsoil	Mid grey brown, silty clay, friable	50	2	
87	8701		layer	Natural	Light brown yellow, silty clay, compact, occasional limestones	50	2	
88	8800		layer	Ploughsoil	Mid grey brown, silty clay, friable	50	2	0.26

88	8801		layer	Subsoil	Mid red brown, silty clay, compact, occasional limestones	50	2	0.1
88	8802		layer	Natural	Light brown yellow, silty clay, compact, occasional limestones	50	2	
88	8803		cut	Ditch	Linear NE-SW. Fairly steep edges with concave base	>1	0.87	0.6
88	8804	8803	fill	Primary Fill	Light brown yellow, silty clay, compact, frequent limestones	>1	0.65	0.14
88	8805	8803	fill	Other Fill	Dark grey brown, sandy clay, compact, rare large pebbles	>1	0.87	0.46
89	8900		layer	Ploughsoil	Mid grey brown, silty clay, friable	50	2	
89	8901		layer	Natural	Light brown yellow, silty clay, compact, occasional limestone	50	2	
90	9000		layer	Ploughsoil	Mid grey brown, silty clay, friable	50	2	
90	9001		layer	Natural	Light brown yellow, silty clay, compact, occasional limestone	50	2	
91	9100		layer	Ploughsoil	Mid grey brown, silty clay, friable	50	2	
91	9101		layer	Natural	Light brown yellow, silty clay, compact, occasional limestone	50	2	
92	9200		layer	Ploughsoil	Mid grey brown, silty clay, friable	50	2	
92	9201		layer	Natural	Light brown yellow, silty clay, compact, occasional limestone	50	2	
93	9300		layer	Ploughsoil	Mid grey brown, silty clay, friable	50	2	
93	9301		layer	Natural	Light brown yellow, silty clay, compact, occasional limestones	50	2	
94	9400		layer	Ploughsoil	Mid grey brown, silty clay, friable	50	2	0.26
94	9401		layer	Natural	Light brown yellow, silty clay, compact, occasional limestones	50	2	
94	9402		cut	Ditch	Linear NE-SW. Steep concave sides, flat base. Possibly modern.	>1	0.45	0.2
94	9403	9402	fill	Other Fill	Light brown grey, silty sand, friable. Occasional small - medium sub angular limestone.	>1	0.45	0.3
95	9500		layer	Ploughsoil	Mid grey brown, silty clay, friable	50	2	0.3
95	9501		layer	Natural	Light brown yellow, silty clay, compact, occasional limestone	50	2	
95	9502		cut	Ditch	Linear NE-SW. Gentle edges with a concave base	>1	2.6	0.22
95	9503	9502	fill	Other Fill	Mid yellow brown, sandy silt, loose, very rare charcoal and frequent sub-angular stones	>1	2.6	0.22
96	9600		layer	Ploughsoil	Mid grey brown, silty clay, friable	50	2	0.3
96	9601		layer	Natural	Light brown yellow, silty clay, compact, occasional limestone	50	2	
96	9602		cut	Ditch	Linear E-W. Fairly steep edges with concave base	>1	0.9	0.36
96	9603	9602	fill	Other Fill	Mid brown yellow, sandy clay, compact, rare flecks of charcoal	>1	0.67	0.09
96	9604	9602	fill	Other Fill	Dark yellow brown, sandy clay, compact, occasional flecks of charcoal and large sub-angular stones	>1	0.9	0.33
97	9700		layer	Ploughsoil	Mid grey brown, silty clay, friable	50	2	0.3
97	9701		layer	Natural	Light brown yellow with red patches, silty clay, friable, frequent limestones	50	2	
98	9800		layer	Ploughsoil	Mid grey brown, silty clay, friable	50	2	0.34
98	9801		layer	Natural	Light brown yellow with red patches, silty clay, friable, frequent limestones	50	2	
99	9900		layer	Ploughsoil	Mid grey brown, silty clay, friable	50	2	0.25
99	9901		layer	Subsoil	Mid red brown, silty clay, friable	50	2	0.2

99	9902		layer	Natural	Light brown yellow with red patches, silty clay, friable, frequent limestones	50	2	
99	9903		cut	Ditch	Linear NE-SW. Steep slopes with concave base	1.5	1	0.57
99	9904	9903	fill	Secondary Fill	Mid grey brown, silty clay, loose, frequent limestones	1	1	0.57
100	10000		layer	Ploughsoil	Mid grey brown, silty clay, friable	50	2	
100	10001		layer	Natural	Light brown yellow with red patches, silty clay, friable, frequent limestones	50	2	
101	10100		layer	Ploughsoil	Mid grey brown, silty clay, friable	50	2	0.3
101	10101		layer	Natural	Light brown yellow with red patches, silty clay, friable, frequent limestones	50	2	
101	10102		cut	Ditch	Linear E-W. Steep slopes, base not excavated due to 1.2m depth limit	>1	2.8	1
101	10103	10102	fill	Secondary Fill	Light brown, silty clay, compact, occasional small limestone and charcoal flecks	>1	2.8	1
101	10104	10102	fill	Secondary Fill	Mid greyish brown. Sandy clay. Firm. Occasional large limestone pieces.	>1	1	0.3
101	10105	10102	fill	Secondary Fill	Mid reddish brown. Silty clay. Friable. Occasional small charcoal and small and medium limestone pieces.	>1	2.8	0.4
102	10200		layer	Ploughsoil	Mid grey brown, silty clay, friable	50	2	0.3
102	10201		layer	Natural	Light brown yellow with red patches, silty clay, friable, frequent limestones	50	2	
102	10202		cut	Ditch	Linear NW-SE. Steep slopes with a concave base.	>1	1.3	0.53
102	10203	10202	fill	Secondary Fill	Mid orange brown, silty clay, compact	>1	1.3	0.53
103	10300		layer	Ploughsoil	Mid grey brown, silty clay, friable	50	2	0.4
103	10301		layer	Natural	Light brown yellow with red patches, silty clay, friable, frequent limestones	50	2	
103	10302		cut	Ditch	Linear NW-SE. Gentle slopes with a concave base	>1	4	0.24
103	10303	10302	fill	Secondary Fill	Mid red brown, silty clay, firm, rare small stones and charcoal	>1	4	0.24
104	10400		layer	Ploughsoil	Mid grey brown, silty clay, friable	50	2	0.35
104	10401		layer	Subsoil	Mid red brown, silty clay, friable	50	2	0.15
104	10402		layer	Natural	Light brown yellow with red patches, silty clay, friable, frequent limestones	50	2	
104	10403		cut	Ditch	Linear NW-SE. Gradual slopes with a concave base	>1	2	0.35
104	10404	10403	fill	Secondary Fill	Dark red brown, silty sand, loose	>1	2	0.35
	10405		cut	Ditch	Linear NW-SE. Gentle slopes with a flat base.	>1	2.5	0.35
104	10406	10405	fill	Secondary Fill	Dark grey brown, sandy silt, loose, occasional limestones	>1	2.5	0.25
104	10407	10405	fill	Secondary Fill	Mid brown red, silty sand, loose, occasional limestones and flint	>1	2.4	0.1
104	10408		cut	Pit	Circular in plan. Steep slopes and concave base	0.45	0.6	0.24
104	10409	10408	fill	Secondary Fill	Mid red brown, sandy silt, loose, occasional limestone	0.45	0.6	0.24
104	10410		cut	Ditch	Linear N-S. Gentle slopes with a concave base.	>1	2.1	0.28
104	10411	10410	fill	Secondary Fill	Light red brown, sandy silt, loose, occasional limestone	>1	2.1	0.28

105	10500		layer	Ploughsoil	Mid grey brown, silty clay, friable	50	2	0.4
105	10501		layer	Natural	Mid brown orange, silty clay, compact, occasional rounded stones	50	2	
106	10600		layer	Ploughsoil	Mid grey brown, silty clay, friable	50	2	0.28
106	10601		layer	Natural	Dark grey brown, silty clay, compact, occasional rounded stones	50	2	
107	10700		layer	Ploughsoil	Mid grey brown, silty clay, friable	50	2	0.22
107	10701		layer	Natural	Dark blue grey with mid orange brown patches, silty clay, compact, occasional rounded stones	50	2	
107	10702		void					
108	10800		layer	Ploughsoil	Mid grey brown, silty clay, friable	50	2	0.4
108	10801		layer	Subsoil	Mid red brown, silty clay, friable	50	2	0.4
108	10802		layer	Natural	Mid brown yellow, silty clay, friable, frequent stones	50	2	
109	10900		layer	Ploughsoil	Mid grey brown, silty clay, friable	50	2	0.4
109	10901		layer	Natural	Mid brown yellow, silty clay, friable, frequent stones	50	2	
110	11000		layer	Ploughsoil	Mid grey brown, silty clay, friable	50	2	0.3
110	11001		layer	Subsoil	Mid red brown, silty clay, friable	50	2	0.25
110	11002		layer	Natural	Mid brown yellow, silty clay, friable, frequent stones	50	2	
111	11100		layer	Ploughsoil	Mid grey brown, silty clay, friable	50	2	0.4
111	11101		layer	Natural	Mid brown yellow, silty clay, friable, frequent stones	50	2	
111	11102		cut	Plough Furrow	Linear N-S. Gradual slopes with a concave base.	>1	2.86	0.39
111	11103	11102	fill	Deliberate Backfill	Light yellow brown, silty clay, firm, occasional charcoal flecks and stones	>1	2.86	0.39
111	11104		unexcavated feature	Plough Furrow	Linear N-S. Fill is light yellow brown, silty clay, firm		2.3	
111	11105		unexcavated feature	Plough Furrow	Linear N-S. Fill is light yellow brown, silty clay, firm		1.1	
111	11106		cut	Ditch	Linear, N-S. Steep slopes with concave base	>1	2.12	0.95
111	11107	11106	fill	Primary Fill	Light red grey, silty clay, friable, occasional stones	>1	0.32	0.26
111	11108	11106	fill	Secondary Fill	Light blue grey, silty clay, friable, occasional stones	>1	0.81	0.28
111	11109	11106	fill	Secondary Fill	Mid red brown, silty clay, friable, rare charcoal	>1	1.62	0.34
111	11110	11106	fill	Secondary Fill	Mid yellow brown, silty clay, friable, rare charcoal	>1	2.12	0.16
111	11111		cut	Natural Feature	Circular in plan. Steep slopes with concave base	>1	0.4	0.35
111	11112	11111	fill	Primary Fill	Light yellow brown, silty clay, friable	>1	0.4	0.35
112	11200		layer	Ploughsoil	Mid brown grey, silty clay, friable	50	2	0.29
112	11201		layer	Subsoil	Mid red brown, silty clay, friable	50	2	0.2
112	11202		layer	Natural	Light brown yellow with red patches, silty clay, friable, frequent limestones	50	2	
112	11203		cut	Ditch	Linear NE-SW. Steep edges with concave base	>1	1.5	0.59
112	11204	11203	fill	Secondary Fill	Light grey brown, silty clay, friable, frequent medium rounded stones and small pebbles	>1	0.98	0.3
112	11205	11203	fill	Deliberate Backfill	Dark grey brown, silty clay, friable, frequent small rounded pebbles	>1	1.5	0.3

112	11206		cut	Ditch	Linear NE-SW. Fairly steep edges with a concave base	>1	0.98	0.18
112	11207	11206	fill	Secondary Fill	Dark grey brown with patches of yellow, silty sand, loose, frequent small rounded stones and pebbles	>1	0.98	0.18
112	11208		cut	Pit	Circular in plan. Fairly steep edges with a concave base	0.63	0.54	0.18
112	11209	11208	fill	Secondary Fill	Mid grey brown with patches of yellow, silty sand, loose, frequent small rounded pebbles	0.63	0.54	0.18
112	11210		cut	Ditch	Linear N-S.		2	
112	11211	11210	fill	Secondary Fill	Unexcavated. Dark grey brown, silty clay, firm, frequent small rounded pebbles and stones		2	
113	11300		layer	Ploughsoil	Mid grey brown, silty clay, friable	50	2	0.27
113	11301		layer	Subsoil	Mid red brown, silty clay, friable	50	2	0.25
113	11302		layer	Natural	Light brown yellow with red patches, silty clay, friable, frequent limestones	50	2	
113	11303		cut	Ditch	Linear NW-SE. Fairly steep edges with a flat base	>1	1.82	0.42
113	11304	11303	fill	Deliberate Backfill	Dark brown grey, silty clay, friable, frequent small to medium rounded stones and pebbles	>1	1.82	0.42
113	11305		cut	Pit	Circular in plan. Steep edges with concave base	0.6	0.5	0.2
113	11306	11305	fill	Secondary Fill	Light brown grey, silty clay, compact, occasional shells and small rounded stones	0.6	0.5	0.2
113	11307		cut	Ditch	Linear NW-SE. Steep edges with concave base	>1.2	0.33	0.26
113	11308	11307	fill	Secondary Fill	Dark brown grey, silty clay, friable, frequent small pebbles	>1.2	0.33	0.26
113	11309		cut	Pit	Circular in plan. Steep edges with concave base	>1.2	0.8	0.38
113	11310	11309	fill	Secondary Fill	Mid brown grey, silty clay, friable, frequent medium rounded stones	>1.2	0.8	0.38
113	11311		cut	Ditch	Linear NW-SE. Steep edges with concave base	>1	1.8	0.73
113	11312	11311	fill	Secondary Fill	Mid brown orange, clayey sand, friable, frequent small rounded pebbles and large stones	>1	1.16	0.37
113	11313	11311	fill	Deliberate Backfill	Dark brown grey, silty clay, firm, frequent small to medium rounded stones and rare charcoal flecks	>1	1.8	0.37
113	11314		cut	Posthole	Circular in plan. Steep edges with a concave base	>0.43	0.31	0.27
113	11315	11314	fill	Deliberate Backfill	Dark brown grey, silty clay, firm, frequent small rounded stones and pebbles	>0.43	0.31	0.27
113	11316		cut	Pit	Circular in plan. Steep edges with concave base	>1.22	0.84	0.21
113	11317	11316	fill	Secondary Fill	Mid grey brown, clayey silt, friable, occasional small rounded stones	>1.22	0.84	0.21
113	11318		cut	Ditch	Linear NW-SE. Fairly gentle slopes with a flat base	>1	1.02	0.12
113	11319	11318	fill	Deliberate Backfill	Dark grey brown, silty clay, firm, frequent large rounded stones	>1	1.02	0.12
113	11320		cut	Ditch	Linear NE-SW. Fairly gentle edges with concave base	>0.3	0.32	0.12
113	11321	11320	fill	Deliberate Backfill	Dark brown grey, silty clay, firm, occasional small rounded pebbles	>0.3	0.32	0.12
113	11322		cut	Ditch	Linear N-S. Fairly steep edges with concave base	>0.63	0.4	0.3
113	11323	11322	fill	Secondary Fill	Dark grey brown, silty clay, firm, occasional small rounded stones	>0.63	0.4	0.3
113	11324		cut	Ditch	Linear NW-SE. Steep edges with a concave base	>0.91	1.21	0.45

113	11325	11324	fill	Deliberate Backfill	Dark brown, silty clay, friable, occasional charcoal flecks and small rounded stones	>0.91	1.03	0.3
113	11326	11340	fill	Secondary Fill	Mid brown orange, silty sand, loose, frequent small rounded pebbles	>1	1.52	0.22
113	11327	11340	fill	Secondary Fill	Mid grey brown, clayey silt, firm, occasional small rounded pebbles	>1	1.52	0.14
113	11328		cut	Ditch	Linear NW-SE. Fairly steep edges with flat base	>1	1	0.26
113	11329	11328	fill	Secondary Fill	Mid grey brown, clay et silt, firm, ?frequent small to medium rounded stones	>1	1	0.26
113	11330		cut	Ditch	Linear NW-SE. Steep edges with concave base	>1	0.9	0.37
113	11331	11330	fill	Secondary Fill	Dark brown grey, silty clay, firm, frequent small rounded stones	>1	0.9	0.37
113	11332		cut	Ditch	Linear NW-SE. Steep edges with concave base	>1	0.8	0.5
113	11333	11332	fill	Deliberate Backfill	Light brown yellow, clayey silt, friable, occasional small rounded gravel	>1	0.17	0.21
113	11334	11332	fill	Other Fill	Mid brown red, silty clay, firm, frequent small to medium rounded stones	>1	0.76	0.5
113	11335	11324	fill	Secondary Fill	Dark brown grey, silty clay, firm, frequent small rounded stones	>0.91	1.21	0.19
113	11336		cut	Pit	Circular in plan. Steep edges with concave base	>0.77	0.81	0.42
113	11337	11336	fill	Secondary Fill	Dark brown grey, silty clay, firm, occasional small rounded stones	>0.77	0.81	0.42
113	11338		cut	Pit	Circular in plan. Fairly gentle edges with concave base	>0.66	0.51	0.21
113	11339	11338	fill	Secondary Fill	Mid orange brown, clayey silt, friable, frequent small rounded stones	>0.66	0.51	0.21
113	11340		cut	Ditch	Linear NW-SE. No edges as cut by features on both sides. Flat base	>1	1.52	0.34
113	11341		unexcavated feature	Ditch	Curvilinear NE-SW and NW-SE. Fill is mid brown grey, silty clay, firm, frequent small rounded pebbles		1	
113	11342		unexcavated feature	Ditch	Linear NW-SE. Fill is dark brown grey, silty clay, compact, occasional small rounded pebbles		1.24	
114	11400		layer	Ploughsoil	Mid grey brown, silty clay, friable	50	2	
114	11401		layer	Subsoil	Mid red brown, silty clay, friable	50	2	
114	11402		layer	Natural	Light brown yellow with red patches, silty clay, friable, frequent limestones	50	2	
114	11403		cut	Ditch	Linear NE-SW. Not visible in plan. Steep edges with concave base	>1	0.94	0.54
114	11404	11403	fill	Secondary Fill	Mid grey, sandy silt, moderately compact	>1	0.92	0.4
114	11405	11403	fill	Secondary Fill	Mid yellow grey, sandy silt, compact, rare small stones	>1	0.84	0.14
114	11406		cut	Ditch	Linear NE-SW. Steep edges with a concave base	>1	7.42	1.38
114	11407	11406	fill	Primary Fill	Light grey, sandy silt, compact, frequent small stones	>1	5.02	0.5
114	11408	11406	fill	Primary Fill	Light grey brown, silty clay, compact, occasional small stones	>1	6.1	0.58
114	11409	11406	fill	Secondary Fill	Mid grey, silty clay, compact, rare small stones	>1	1.84	0.58
114	11410	11406	fill	Secondary Fill	Mid grey, silty clay, compact	>1	3.2	0.44
114	11411	11406	fill	Secondary Fill	Mid grey brown, silty clay, compact	>1	4.38	0.28

114	11412	11406	fill	Tertiary Fill	Dark brown, silty clay, compact, frequent small stones	>1	6.58	0.14
114	11413	11406	fill	Other Fill	Dark brown silty clay, loose, occasional small stones	>1	7.34	0.46
114	11414		cut	Ditch	Linear NW-SE. Gentles slopes with concave base	>1	1.94	0.66
114	11415	11414	fill	Secondary Fill	Mid brown, silty clay, friable, occasional stones	>1	1.94	0.66
114	11416		cut	Ditch	Curvi-linear NW-SE. Steep slopes with concave base	>1	0.96	0.45
114	11417	11416	fill	Secondary Fill	Dark brown, silty clay, friable, occasional stones	>1	0.96	0.45
114	11418		cut	Ditch	Linear E-W. Steep slopes with concave base	>1	0.3	0.12
114	11419	11418	fill	Secondary Fill	Dark brown black, silty clay, friable, rare small stones	>1	0.43	0.12
114	11420		unexcavated feature	Ditch	Linear NW-SE. Fill is mid brown, silty clay, friable, frequent stones		1.1	
114	11421		cut	Pit	Circular in plan. Unexcavated		0.48	
114	11422	11421	fill	Secondary Fill	Dark grey brown, silty clay, friable		0.48	
114	11423		unexcavated feature	Pit	Oval in plan. Fill is dark brown grey, silty clay, friable		0.45	
115	11500		layer	Ploughsoil	Mid grey brown, silty clay, friable	50	2	0.26
115	11501		layer	Subsoil	Mid red brown, silty clay, friable	50	2	0.5
115	11502		layer	Natural	Light brown yellow with red patches, silty clay, friable, frequent limestones	50	2	
115	11503		cut	Ditch	Linear E-W. Gentle slopes with concave base	>1	0.85	0.15
115	11504	11503	fill	Primary Fill	Dark yellow brown, clayey silt, friable	>1	0.85	0.15
115	11505		cut	Ditch	Linear E-W. Moderate slopes with flat base	>1	4.4	0.6
115	11506	11505	fill	Primary Fill	Dark Red Brown, Clayey Silt, Friable, <%1 Charcoal	>1	2	0.4
115	11507	11505	fill	Secondary Fill	Mid Grey Brown, Silty clay, friable, frequent sub-angular stones and occasional chalk and shells	>1	4.4	0.2
115	11508		cut	Ditch	Linear E-W. Gentle slopes with flat base	>1	1.2	0.3
115	11509	11508	fill	Primary Fill	Mid Grey Brown, Clayey Silt, Friable	>1	1.2	0.3
115	11510		cut	Ditch	Linear E-W. Moderate slopes with concave base	>1	1.06	0.28
115	11511	11510	fill	Primary Fill	Light Yellow Brown, silty clay, firm	>1	1.06	0.28
115	11512		cut	Natural Feature	No section. Linear E-W. Fairly gentle edges with flat base	>1	1	0.2
115	11513	11512	fill	Secondary Fill	Mid brown grey, silty clay, friable, occasional small rounded stones	>1	1	0.2
115	11514		cut	Ditch	Linear NE-SW. Steep edges with concave base	>1.5	>1.1	0.68
115	11515	11514	fill	Primary Fill	Mid Yellow Brown, Silty Clay, Friable, occasional flint	>1.5	0.6	0.1
115	11516	11514	fill	Secondary Fill	Mid Yellow Brown, Sandy Silt, Friable, frequent sub-angular stones	>1.5	0.86	0.15
115	11517	11514	fill	Secondary Fill	Dark Grey Brown, Silty Clay, Friable, occasional small sub-angular stones	>1.5	1.16	0.35
115	11518	11514	fill	Tertiary Fill	Dark Brown Grey, Silty Clay, Friable, frequent small sub-angular stones	>1.5	1	0.2
115	11519		unexcavated feature	Pit	Circular in plan. Fill is dark brown grey, silty clay, firm		0.65	
116	11600		layer	Ploughsoil	Mid grey brown, silty clay, friable	50	2	0.32
116	11601		layer	Subsoil	Mid red brown, silty clay, friable	50	2	0.11

116	11602		layer	Natural	Light brown yellow with red patches, silty clay, friable, frequent limestones	50	2	
116	11603		cut	Ditch	Linear E-W. Gentle slopes with flat base	>1	2.8	0.52
116	11604	11603	fill	Secondary Fill	Mid grey brown, sandy clay, firm, frequent gravel and occasional stones	>1	2.8	0.52
116	11605	11603	fill	Secondary Fill	Light yellow brown, sandy clay, firm, frequent gravel and stones	>1	1.45	0.25
116	11606	11603	fill	Secondary Fill	Dark brown grey, silty clay, soft, occasional stones	>1	1.9	0.3
116	11607		layer	Other Layer	Spread of material. Mid grey brown, sandy clay, firm, frequent stones	>1	0.5	0.2
116	11608		layer	Other Layer	Dark blue grey, silty clay, firm	>11.7	>2	0.26
116	11609		cut	Pit	Sub-circular in plan. Steep sloping sides with unknown base		1.8	0.64
116	11610	11609	fill	Secondary Fill	Mid grey brown, silty clay, friable, frequent stones		1.68	0.28
116	11611	11609	fill	Secondary Fill	Mid brown grey, silty clay, friable, frequent stones		0.8	0.6
116	11612		cut	Ditch	Linear NE-SW. Steep slopes with concave base	>2.5	3	0.6
116	11613	11612	fill	Secondary Fill	Mid grey brown, silty clay, friable, frequent stones	>2.5	1.26	0.18
116	11614	11612	fill	Secondary Fill	Light white brown, sandy clay, friable, frequent stones	>2.5	0.76	0.14
116	11615	11612	fill	Secondary Fill	Mid brown grey with red patches, silty clay, friable, frequent stones	>2.5	2.6	0.4
116	11616	11612	fill	Secondary Fill	Mid blue grey with red patches, silty clay, friable, frequent stones	>2.5	1.02	0.24
116	11617	11612	fill	Secondary Fill	Light orange brown, sandy clay, friable, frequent stones	>2.5	0.56	0.24
116	11618		layer	Other Layer	Light white brown, sandy clay, friable, frequent gravel	>2	3.2	0.08
117	11700		layer	Ploughsoil	Mid grey brown, silty clay, friable	50	2	0.32
117	11701		layer	Subsoil	Mid red brown, silty clay, friable	50	2	0.1
117	11702		layer	Natural	Light brown yellow with red patches, silty clay, friable, frequent limestones	50	2	
117	11703		cut	Ditch	Linear NE-SW. Moderate sloping sides and concave base.	>2.6	1.58	0.4
117	11704	11703	fill	Deliberate Backfill	Dark grey brown, silty clay, friable, moderate small sub-rounded stones	>2.6	1.58	0.4
117	11705		cut	Ditch	Linear NE-SW. Steep/oblique sides and flat base.	>2.6	2.15	0.58
117	11706	11705	fill	Secondary Fill	Dark grey brown, silty clay, friable, frequent sub-angular gravels and stones.	>2.6	0.65	0.07
117	11707	11705	fill	Secondary Fill	Mid orange brown, silty clay, firm, occasional sub-angular stones	>2.6	2.15	0.19
117	11708		cut	Ditch	Linear N-S. Very truncated. Steep sides and uneven base.	>1.83	0.35	0.2
117	11709	11708	fill	Secondary Fill	Dark red brown, silty clay, friable, moderate small and medium sub-angular stones	>1.83	0.35	0.2
117	11710		cut	Ditch	Linear NE-SW. Moderate and slightly convex sides with a flat base.	>2.06	1.05	0.2
117	11711	11710	fill	Deliberate Backfill	Dark grey brown with yellow flecks, silty clay, friable, moderate small and medium sized angular stones and flint	>2.06	1.05	0.2
118	11800		layer	Ploughsoil	Mid grey brown, silty clay, friable	50	2	0.35
118	11801		layer	Subsoil	Mid red brown, silty clay, friable	50	2	0.21

118	11802		layer	Natural	Light brown yellow with red patches, silty clay, friable, frequent limestones	50	2	
118	11803		cut	Ditch	Linear E-W. Steep edges with concave base	>2.2	2.16	0.76
118	11804	11803	fill	Secondary Fill	Mid brown, sandy silt, soft, rare small pebbles	>1	1.68	0.16
118	11805	11803	fill	Secondary Fill	Mid orange yellow, silty sand, loose, frequent medium pebbles	>1	1.3	0.5
118	11806		cut	Ditch	Linear E-W. Steep edges with concave base	>2.2	1.37	0.6
118	11807	11806	fill	Secondary Fill	Mid grey brown, sandy silt, soft, rare small pebbles	>1	0.68	0.11
118	11808	11806	fill	Secondary Fill	Dark black, silty clay, soft, frequent charcoal	>1	0.72	0.15
118	11809	11806	fill	Secondary Fill	Mid grey brown, sandy silt, soft, rare small pebbles	>1	1.38	0.4
118	11810		cut	Ditch	Linear NE-SW. Steep edges with concave base	>2.2	0.38	0.38
118	11811	11810	fill	Primary Fill	Mid orange brown, silty clay, soft, rare small pebbles	>2.2	0.38	0.38
118	11812		cut	Ditch	Linear NW-SE. Steep edges with concave base	>2.2	0.65	0.27
118	11813	11812	fill	Primary Fill	Mid grey brown, silty clay, soft, rare small pebbles	>2.2	0.65	0.27
118	11814	11812	fill	Secondary Fill	Dark grey brown, silty clay, soft, frequent charcoal	>2.2	0.35	0.14
118	11815		cut	Ditch	Linear E-W. Gentle slopes with concave base	>2.2	1.55	0.3
118	11816	11815	fill	Primary Fill	Mid grey brown, sandy silt, soft, occasional small pebbles	>2.2	1.55	0.3
118	11817		unexcavated feature	Ditch	Linear NE-SW. Fill is dark brown grey, silty clay, friable		1	
118	11818		layer	Other Layer	Large spread. Unexcavated. Fill is mid brown grey, silty clay, firm.		2	
119	11900		layer	Ploughsoil	Mid grey brown, silty clay, friable	50	2	0.38
119	11901		layer	Subsoil	Mid red brown, silty sand, friable	50	2	0.21
119	11902		layer	Natural	Light brown yellow with red patches, silty clay, friable, frequent limestones	50	2	
119	11903		cut	Ditch	Linear E-W. Steep edges with uneven base	>2.35	2.25	0.46
119	11904	11903	fill	Secondary Fill	Light orange brown, sandy clay, soft, frequent small stones	>2.35	2.25	0.46
119	11905		cut	Ditch	Linear E-W. Steep slopes with uneven base	>2.35	1.65	0.46
119	11906	11905	fill	Deliberate Backfill	Dark brown, sandy silt, soft, frequent small pebbles and stones	>2.35	1.65	0.46
119	11907		cut	Ditch	Linear E-W. Moderate slopes with concave base	>2.3	1.57	0.52
119	11908	11907	fill	Secondary Fill	Dark grey brown, silty clay, soft, occasional small rocks	>2.3	1.57	0.27
119	11909	11907	fill	Secondary Fill	Mid brown, silty clay, soft, rare small stones	>2.3	1.05	0.25
119	11910		cut	Ditch	Linear NW-SE. Steep edges with uneven base	>2.8	0.8	0.27
119	11911	11910	fill	Secondary Fill	Mid grey brown, silty clay, loose, occasional small stones	>2.8	0.8	0.27
119	11912		cut	Pit	Oval in plan. Gentle slopes with flat base	>1.4	2.5	0.1
119	11913	11912	fill	Secondary Fill	Mid brown, sandy clay, loose, rare small pebbles	>1.4	2.5	0.1
119	11914		cut	Pit	Circular in plan. Gentle slopes with concave base	1.27	1.43	0.31
119	11915	11914	fill	Secondary Fill	Mid brown, sandy silt, firm, occasional small pebbles	1.27	1.43	0.31
119	11916		cut	Pit	Circular in plan. Gentle slopes with concave base	0.6	0.6	0.23

119	11917	11916	fill	Secondary Fill	Light brown, sandy silt, loose, frequent small pebbles	0.65	0.6	0.23
119	11918		unexcavated feature	Posthole	Circular in plan. Fill is mid grey brown, silty clay, friable		0.4	
120	12000		layer	Ploughsoil	Mid grey brown, silty clay, friable	50	2	0.3
120	12001		layer	Subsoil	Mid red brown, silty clay, friable	50	2	0.38
120	12002		layer	Natural	Light brown yellow with red patches, silty clay, friable, frequent limestones	50	2	
120	12003		cut	Ditch	Linear E-W in plan. Steep edges with concave base	>1	0.62	0.38
120	12004	12003	fill	Secondary Fill	Mid grey brown, silty clay, friable, occasional small rounded stones	>1	0.62	0.38
120	12005		cut	Tree Throw	Circular in plan. Fairly steep edges with an irregular base	>0.8	0.8	0.27
120	12006	12005	fill	Secondary Fill	Mid grey brown, silty clay, firm, occasional small rounded stones	>0.8	0.8	0.27
120	12007		unexcavated feature	Tree Throw	Circular in plan. Fill is a mid grey brown, silty clay, firm, occasional roots		1.2	
120	12008		unexcavated feature	Tree Throw	Irregular in plan. Fill is a mid grey brown, silty clay, firm, occasional roots		1.72	
121	12100		layer	Ploughsoil	Mid grey brown, silty clay, friable	50	2	0.35
121	12101		layer	Subsoil	Mid red brown, silty clay, friable	50	2	0.34
121	12102		layer	Natural	Light brown yellow with red patches, silty clay, friable, frequent limestones	50	2	
121	12103		cut	Ditch	Linear N-S. Steep edges with concave base	>1	1.6	0.65
121	12104	12103	fill	Primary Fill	Mid yellow brown, sandy silt, friable, occasional rounded stones	>1	0.8	0.2
121	12105	12103	fill	Secondary Fill	Mid grey brown, sandy silt, friable, occasional small rounded stones	>1	1.2	0.35
121	12106	12103	fill	Secondary Fill	Dark brown grey, clayey silt, friable, occasional rounded stones	>1	0.84	0.18
121	12107		cut	Pit	Circular in plan. Fairly gentle edges with concave base	1.74	1.4	0.18
121	12108	12107	fill	Secondary Fill	Mid grey brown, clayey sand, friable, frequent small rounded pebbles	1.74	1.4	0.18
121	12109		cut	Ditch	Linear N-S. Steep edges with a concave base	>1	1.18	0.6
121	12110	12109	fill	Secondary Fill	Mid brown orange, clayey sand, friable, frequent small pebbles	>1	0.7	0.24
121	12111	12109	fill	Secondary Fill	Dark grey brown, clayey sand, firm, frequent shells and small rounded stones	>1	1.18	0.36
121	12112		cut	Ditch	Linear N-S. Steep edges with a flat base	>1	0.32	0.26
121	12113	12112	fill	Secondary Fill	Light grey brown, clayey sand, friable, frequent small pebbles	>1	0.32	0.26
122	12200		layer	Ploughsoil	Mid grey brown, silty clay, friable	50	2	0.31
122	12201		layer	Natural	Light brown yellow with red patches, silty clay, friable, frequent limestones	50	2	
123	12300		layer	Ploughsoil	Mid grey brown, silty clay, friable	50	2	0.32
123	12301		layer	Natural	Light brown yellow with red patches, silty clay, friable, frequent limestones	50	2	
123	12302		cut	Ditch	Linear E-W. Moderate slopes and concave base	>2.5	0.75	0.2
123	12303	12302	fill	Secondary Fill	Mid red brown, silty clay, firm, moderate sub-angular small to medium stones and flint	>2.5	0.75	0.2
124	12400		layer	Ploughsoil	Mid grey brown, silty clay, friable	50	2	0.32

124	12401		layer	Natural	Light brown yellow with red patches, silty clay, friable, frequent limestones	50	2	
124	12402		void					
125	12500		layer	Ploughsoil	Mid grey brown, silty clay, friable	50	2	0.36
125	12501		layer	Natural	Mid yellow brown with white chalk patches, silty clay, compact, frequent limestones	50	2	
126	12600		layer	Ploughsoil	Mid grey brown, silty clay, friable	50	2	0.33
126	12601		layer	Natural	Mid brown yellow, silty clay with white chalk patches, compact, occasional limestones	50	2	
127	12700		layer	Ploughsoil	Mid grey brown, silty clay, friable	50	2	0.34
127	12701		layer	Subsoil	Light brown red, silty clay, friable	50	2	0.26
127	12702		layer	Natural	Mid brown yellow, silty clay with white chalk patches, friable, frequent limestones	50	2	
127	12703		cut	Ditch	Curvilinear N-S and NE-SW. Moderate slopes with a flat base.	>1	1.82	0.46
127	12704	12703	fill	Primary Fill	Light red brown, silty clay, friable, occasional stones and rare charcoal	>1	1.82	0.46
127	12705		cut	Ditch	Linear N-S. Steep slopes with a flat base	>1	0.9	0.43
127	12706	12705	fill	Primary Fill	Light red brown, silty clay, friable, occasional stones and rare charcoal	>1	0.9	0.43
127	12707		unexcavated feature	Ditch	Linear N-S. Fill is dark grey brown, silty clay, firm, occasional stones		1.17	
128	12800		layer	Ploughsoil	Mid grey brown, silty clay, friable	50	2	0.35
128	12801		layer	Natural	Mid yellow brown with white chalk patches, silty clay, compact, frequent limestones	50	2	
128	12802		cut	Ditch	Linear E-W. Gentle slopes with flat base	>1	0.87	0.18
128	12803	12802	fill	Primary Fill	Mid Grey Brown, Silty Clay, friable, occasional sub-angular stones.	>1	0.87	0.18
129	12900		layer	Ploughsoil	Mid Grey Brown, Silty Clay, Friable	50	2	0.35
129	12901		layer	Natural	Light Brown Grey, silty clay, compact, frequent sandstones	50	2	
129	12902		cut	Ditch	Curvilinear E-W and NW-SE. Moderate slopes with a flat base	>1	0.75	0.22
129	12903	12902	fill	Primary Fill	Mid Grey Brown, Silty Clay, Friable, frequent medium sub-angular stones	>1	0.75	0.22
129	12904		cut	Pit	Circular in plan. Moderate slopes with concave base	1.5	1.2	0.22
129	12905	12904	fill	Primary Fill	Mid Red Brown, Silty Clay, Friable, <5% Sandstone 40% Mid Size Sub Angular Stones	1.5	1.2	0.22
129	12906		unexcavated feature	Ditch	Mid Grey Brown, Silty Clay, Friable, frequent medium sub-angular stones		0.6	
130	13000		layer	Ploughsoil	Mid grey brown, silty clay, friable	50	2	0.3
130	13001		layer	Natural	Mid brown white, silty chalk, friable with red clay patches	50	2	
130	13002		cut	Ditch	Linear NW-SE. Moderate sloping sides and concave base.	>3.3	0.65	0.25
130	13003	13002	fill	Secondary Fill	Mid red brown, silty clay, friable, frequent medium and large sub-angular limestones.	>3.3	0.65	0.25
130	13004		cut	Ditch	Linear NE-SW. Steep slopes with a concave base.	>3.5	0.88	0.24
130	13005		fill	Secondary Fill	Mid red brown, silty clay, friable, frequent stones	>3.5	0.88	0.24

131	13100		layer	Ploughsoil	Mid grey brown, silty clay, friable	50	2	0.35
131	13101		layer	Natural	Mid brown white, silty chalk, friable with red clay patches, frequent limestone	50	2	
131	13102		cut	Plough Furrow	Linear NE-SW. Gentle slopes with flat base		0.83	
131	13103	13102	fill	Primary Fill	Dark brown grey, silty clay, friable, plastic bag remnants		0.83	
132	13200		layer	Ploughsoil	Mid grey brown, silty clay, friable	50	2	0.32
132	13201		layer	Natural	Mid blue grey, silty clay, compact with patches of red clay.	50	2	
133	13300		layer	Ploughsoil	Mid grey brown, silty clay, friable	50	2	0.38
133	13301		layer	Natural	Mid brown white, silty chalk, friable with patches of red clay	50	2	
134	13400		layer	Ploughsoil	Mid grey brown, silty clay, friable	50	2	0.38
134	13401		layer	Natural	Mid brown white, silty chalk, friable with red clay at the NE end	50	2	
135	13500		layer	Ploughsoil	Dark grey brown, silty clay, friable	50	2	0.3
135	13501		layer	Subsoil	Mid red brown, silty clay, friable	50	2	0.18
135	13502		layer	Natural	Mid brown white, silty clay, compact, frequent small rounded stones	50	2	
135	13503		cut	Ditch	Linear N-S. Steep edges with a flat base	>2.2	1.2	0.2
135	13504	13503	fill	Deliberate Backfill	Mid brown black, silty clay, soft, occasional small pebbles	>2.2	1.2	0.2
135	13505		cut	Ditch	Linear N-S. Steep edges with flat base	>2.2	0.67	0.3
135	13506	13505	fill	Primary Fill	Mid brown, silty clay, soft, rare small pebbles	>2.2	0.67	0.3
136	13600		layer	Ploughsoil	Mid grey brown, silty clay, friable	50	2	0.3
136	13601		layer	Subsoil	Mid red brown, silty clay, friable	50	2	0.16
136	13602		layer	Natural	Mid brown yellow, silty clay, compact, frequent limestones	50	2	
136	13603		cut	Ditch	NE-SW linear, gradually sloped sides, concave base	>2	1.35	0.16
136	13604	13603	fill	Secondary Fill	Mid grey brown silty clay, friable	>2	0.38	0.08
136	13605	13603	fill	Deliberate Backfill	Mid brown grey silty clay, friable	>1	0.74	0.07
136	13606	13603	fill	Secondary Fill	dark grey brown silty clay, friable	>1	1.35	0.1
137	13700		layer	Ploughsoil	Mid grey brown, silty clay, friable	50	2	0.35
137	13701		layer	Subsoil	Mid red brown, silty clay, friable	50	2	0.15
137	13702		layer	Natural	Mid brown white, silty chalk, friable, frequent limestone	50	2	
137	13703		cut	Ditch	Linear N-S. Fairly gentle edges with concave base	>1.1	0.5	0.1
137	13704	13703	fill	Secondary Fill	Dark grey brown, sandy clay, friable	>1.1	0.5	0.1
138	13800		layer	Ploughsoil	Mid grey brown, silty clay, friable	50	2	0.3
138	13801		layer	Subsoil	Mid red brown, silty clay, friable	50	2	0.5
138	13802		layer	Natural	Light white yellow, silty sand, friable with patches of clay	50	2	
139	13900		layer	Ploughsoil	Mid grey brown, silty clay, friable	50	2	0.3
139	13901		layer	Subsoil	Mid yellow brown, silty clay, friable	50	2	0.12
139	13902		layer	Natural	Mid orange brown, sandy silt, friable, frequent small stone inclusions	50	2	
139	13903		cut	Ditch	Linear NW-SE. Steep edges with concave base	>1	1.26	0.34
139	13904	13903	fill	Secondary Fill	Mid brown, sandy silt, firm, rare small stones	>1	1.26	0.34

140	14000		layer	Ploughsoil	Mid grey brown, silty clay, friable	50	2	0.24
140	14001		layer	Subsoil	Mid yellow brown, silty clay, friable	50	2	0.17
140	14002		cut	Tree Throw	Irregular shaped, near vertical sides, flat base		0.8	0.13
140	14003	14002	fill	Secondary Fill	Mid grey-orange gravelly-sand, firm. Frequent limestone and flint	>0.5	0.8	0.13
140	14004		cut	Ditch	Linear running SW-NE, steep concave sides, slightly concave base	>0.5	1.5	0.48
140	14005	14004	fill	Secondary Fill	Mid brown silty sand, soft and sticky but friable. Occasional small pieces of limestone and yellow-brown sand	>1	1.5	0.48
140	14006		cut	Ditch	Linear running E-W, concave sides, rounded base	>1	0.44	0.22
140	14007	14006	fill	Secondary Fill	Mid grey-brown sandy clay, soft and plastic. Occasional small limestone pieces	>1	0.44	0.22
140	14008		layer	Natural	Mid yellow orange, sandy silt, friable, frequent stone inclusions	50	2	
140	14009		cut	Ditch	Linear running E-W, gradual straight sides, concave base	>1	1.7	0.39
140	14010	14009	fill	Secondary Fill	Mid yellowish-brown silt, firm. Rare small round/angular stones, rare charcoal	>1	1.7	0.29
140	14011	14009	fill	Tertiary Fill	Mid yellowish-brown sandy silt, friable. Rare small angular stones, rare charcoal	>1	1.7	0.12
140	14012		cut	Ditch	Linear running E-W, convex gentle slopes, rounded concave base	>1	0.95	0.34
140	14013	14012	fill	Secondary Fill	Mid brown sandy silt, friable. Occasional medium limestone, occasional small limestone	>1	0.9	0.34
140	14014		cut	Pit	Irregular, steep sides, concave base	>1	1.2	0.43
140	14015	14014	fill	Secondary Fill	Mid brown silt, firm. Rare flint and limestone, moderate charcoal, moderate slag	>1	1.2	0.43
140	14016	14014	fill	Deliberate Backfill	Mid grey- brown silt, firm. Moderate charcoal, slag, flint and limestone	>1	1.2	0.1
140	14017		cut	Pit	Circular, shallow sides, flat base	0.7	0.45	0.28
140	14018	14017	fill	Secondary Fill	Mid brown-grey silt, firm. Moderate slag, rare limestone and flint	0.7	0.45	0.2
140	14019	14017	fill	Deliberate Backfill	Dark brown-grey sandy silt, firm. Frequent charcoal, moderate slag		0.35	0.08
141	14100		layer	Ploughsoil	Mid grey brown, silty clay, friable	50	2	0.2
141	14101		layer	Subsoil	Mid yellow brown, silty clay, friable	50	2	0.1
141	14102		layer	Natural	Mid yellow orange, sandy silt, friable, frequent stone inclusions	50	2	
141	14103		cut	Ditch	Curvilinear running NE-S-SW, rounded corners, convex 40° sides, fairly flat base	>1	1.3	0.34
141	14104	14103	fill	Secondary Fill	Pale brown silty sandy clay, soft and plastic. Occasional small limestone pieces	>1	1.3	0.34
142	14200		layer	Ploughsoil	Mid grey brown, silty clay, friable	5	2	0.25
142	14201		layer	Subsoil	Mid yellow brown, silty clay, friable	50	2	0.15
142	14202		layer	Natural	Mid yellow orange, sandy silt, friable, frequent stone inclusions	50	2	
142	14203		void					
142	14204		cut	Ditch	Linear running NNE-SSW, gradual concave sides, flat base	>1	1.7	0.35

142	14205		fill	Secondary Fill	Darker mid brown silty sand, loose. Occasional small limestone pieces	>1	1.7	0.35
143	14300		layer	Ploughsoil	Mid grey brown, silty clay, friable	50	2	0.2
143	14301		layer	Subsoil	Mid yellow brown, silty clay, friable	50	2	0.1
143	14302		layer	Natural	Mid brown yellow, sandy silt, friable, frequent stone inclusions	50	2	
143	14303		cut	Plough Furrow	Linear running E-W, shallow sides, concave/flat base	>1	2.1	0.13
143	14304	14303	fill	Secondary Fill	Light yellow-brown sandy silty gravel, firm. Frequent flint, limestone, rare coal(?)	>1	2.1	0.13
144	14400		layer	Ploughsoil	Mid grey brown, silty clay, friable	50	2	0.24
144	14401		layer	Subsoil	Light yellow brown, silty clay, friable	50	2	0.11
144	14402		layer	Natural	Mid orange yellow, silty clay, firm, occasional gravel	50	2	
144	14403		cut	Pit	Irregular, gradual concave sides, rounded concave base	0.85	0.85	0.2
144	14404	14403	fill	Secondary Fill	Pale brown silty sand, loose. Occasional small limestone pieces	0.85	0.85	0.2
144	14405	14403	fill	Deliberate Backfill	Dark grey sandy silt, soft. Frequent charcoal	0.85	0.3	0.09
145	14500		layer	Ploughsoil	Mid grey brown, clayey silt friable	50	2	0.34
145	14501		layer	Natural	Mixture of friable mid brownish-yellow silty sand, gravel and light brownish-yellow fine sand.	50	2	
145	14502		layer	Natural	Compact light grey gravelly sand.	50	2	
145	14503		cut	Ditch	Terminus, NW/SE aligned. Steep sides, flat base.	>1.37	0.51	0.23
145	14504	14503	fill	Secondary Fill	Friable mid brownish-grey sandy silt. Occasional sub-rounded stone (<30mm), charcoal (<10mm) and wood (<20mm).	>1.37	0.51	0.23
145	14505		cut	Ditch	Linear running E-W, moderately straight sides, concave base	>1	3.05	0.43
145	14506	14505	fill	Secondary Fill	Mid greyish-brown silty clay, soft. Occasional small stones	>1	3.05	0.43
145	14507		cut	Ditch	Linear running E-W, moderately rounded sides, concave base	>1	2.09	0.29
145	14508	14507	fill	Deliberate Backfill	Mid orangeish-brown silty clay, soft. Occasional small stones	>1	2.09	0.29
145	14509		cut	Ditch	Linear running SE-NW, straight moderately sloping sides, concave base	>1	1.67	0.41
145	14510	14509	fill	Primary Fill	Mid yellowish-brown silty sand, friable. Occasional small stones	>1	1.67	0.12
145	14511	14509	fill	Secondary Fill	Mid brown silty clay, soft. Occasional small stones	>1	1.46	0.31
146	14600		layer	Ploughsoil	Mid grey brown, silty clay, friable	50	2	0.28
146	14601		layer	Subsoil	Mid yellow brown, silty clay, friable	50	2	0.1
146	14602		layer	Natural	Mid brown orange, silty clay with yellow sandy patches, firm, occasional gravel	50	2	
146	14603		cut	Ditch	Linear NW-SE. Steep edges and a flat base	>1	0.6	0.35
146	14604	14603	fill	Secondary Fill	Mid yellow brown, silty clay, firm, rare small stones	>1	0.6	0.35
146	14605		cut	Ditch	Linear NE-SW. Fairly steep edges with concave base	>1	0.7	0.2
146	14606	14605	fill	Secondary Fill	Mid grey brown, silty clay, firm, occasional small rounded stones	>1	0.7	0.2
146	14607		cut	Pit	Circular in plan. Fairly steep edges with concave base	0.54	0.54	0.11
146	14608	14607	fill	Deliberate Backfill	Dark brown grey, silty clay, firm, occasional charcoal flecks	0.54	0.54	0.11

146	14609		cut	Ditch	Linear NE-SW. Steep edges with concave base	>1	1.36	0.46
146	14610	14609	fill	Deliberate Backfill	Dark brown grey, silty clay, compact, occasional small stones	>1	1.36	0.46
146	14611		cut	Plough Furrow	Linear NE-SW. Fairly gentle edges with flat base	>1	0.44	0.13
146	14612	14611	fill	Secondary Fill	Light yellow brown, sandy silt, friable, frequent small stones	>1	0.44	0.13
146	14613		cut	Ditch	Linear running N-S, shallow sides, flat base	>1	1.5	0.43
146	14614	14613	fill	Secondary Fill	Light yellow-brown sandy silt, firm. Frequent charcoal, rare flint and limestone	>1	1.5	0.43
147	14700		layer	Ploughsoil	Mid grey brown, silty clay, friable	50	2	0.24
147	14701		layer	Subsoil	Mid yellow brown, silty clay, friable	50	2	0.12
147	14702		layer	Natural	Mid brown orange, silty clay with yellow sandy patches, firm, occasional gravel	50	2	
147	14703		cut	Ditch	Linear running NW-SE, steep convex sides, base not reached	>1	3.4	>0.6
147	14704	14703	fill	Secondary Fill	Mid brown silty sand, loose. Moderate small limestone pieces, occasional charcoal and medium flints	>1	3.4	
147	14705	14703	fill	Deliberate Backfill	Pale cream sandy silt, hard. Occasional pale brown sand	>1	1.85	0.08
147	14706	14703	fill	Deliberate Backfill	Pale brown silty sand, loose. Occasional small limestone pieces	>1	1.62	0.26
147	14707		cut	Plough Furrow	Linear running NW-SE, gradual concave sides, flat base	>1	2.4	0.12
147	14708	14707	fill	Secondary Fill	Mid reddish-brown silty sand, loose. Occasional small limestone pieces	>1	2.4	0.12
148	14800		layer	Ploughsoil	Mid grey brown, silty clay, friable	50	2	0.23
148	14801		layer	Subsoil	Mid yellow brown, silty clay, friable	50	2	0.12
148	14802		layer	Natural	Mid brown orange, silty clay with yellow sandy patches, firm, occasional gravel	50	2	
149	14900		layer	Ploughsoil	Mid grey brown, silty clay, friable	50	2	0.28
149	14901		layer	Subsoil	Mid yellow brown, silty clay, friable	50	2	0.3
149	14902		layer	Natural	Mid brown orange, silty clay, firm, occasional gravel	50	2	
150	15000		layer	Ploughsoil	Mid grey brown, silty clay, friable	50	2	0.24
150	15001		layer	Subsoil	Mid yellow brown, silty clay, friable	50	2	0.13
150	15002		layer	Natural	Mid brown orange, silty clay with yellow sandy patches, firm, occasional gravel	50	2	
150	15003		cut	Pit	Sub-rectangular, steep regular sides, flat regular base	0.84	0.35	0.22
150	15004	15003	fill	Deliberate Backfill	Mid yellowish-brown sandy silt, friable. Rare charcoal	0.84	0.35	0.22
151	15100		layer	Ploughsoil	Mid grey brown, silty clay, friable	50	2	0.24
151	15101		layer	Subsoil	Mid yellow brown, silty clay, friable	50	2	0.1
151	15102		layer	Natural	Mid brown orange, silty clay with yellow sandy patches, firm, occasional gravel	50	2	
151	15103		cut	Pit	Sub-circular, gentle shallow sides, flat base	0.45	0.5	0.08
151	15104	15103	fill	Secondary Fill	Mid yellowish-brown sandy silt, firm. Occasional charcoal	0.45	0.5	0.08
151	15105		cut	Ditch	Linear running NE-SW, steep slightly concave sides, concave base	>2	0.9	0.27
151	15106	15105	fill	Secondary Fill	Mid blue-grey clay, plastic. Rare stones - small/medium, angular	>2	0.9	0.27

152	15200		layer	Ploughsoil	Mid grey brown, silty clay, friable	50	2	0.25
152	15201		layer	Subsoil	Mid yellow brown, silty clay, friable	50	2	0.1
152	15202		layer	Natural	Mid brown orange, silty clay with yellow sandy patches, firm, frequent stones	50	2	
153	15300		layer	Ploughsoil	Mid grey brown, silty clay, friable	50	2	0.25
153	15301		layer	Subsoil	Mid yellow brown, silty clay, friable	50	2	0.12
153	15302		layer	Natural	Mid orange yellow, silty clay, firm, frequent stones	50	2	
154	15400		layer	Ploughsoil	Mid grey brown, silty clay, friable	50	2	0.25
154	15401		layer	Subsoil	Mid yellow brown, silty clay, friable	50	2	0.15
154	15402		layer	Natural	Mid orange yellow, silty clay, firm, frequent stones	50	2	
155	15500		layer	Ploughsoil	Mid grey brown, silty clay, friable	50	2	0.3
155	15501		layer	Subsoil	Mid yellow brown, silty clay, friable	50	2	0.1
155	15502		layer	Natural	Mid orange yellow, silty clay, firm, frequent stones	50	2	
156	15600		layer	Ploughsoil	Mid grey brown, silty clay, friable	50	2	0.3
156	15601		layer	Subsoil	Mid yellow brown, silty clay, friable	50	2	0.1
156	15602		layer	Natural	Mid orange yellow, silty clay, firm, frequent stones	50	2	
157	15700		layer	Ploughsoil	Mid grey brown, silty clay, friable	50	2	0.2
157	15701		layer	Subsoil	Mid yellow brown, silty clay, friable	50	2	0.14
157	15702		layer	Natural	Mid orange yellow, silty clay, firm, frequent stones	50	2	
158	15800		layer	Ploughsoil	Mid grey brown, silty clay, friable	50	2	0.5
158	15801		layer	Natural	Mid brown yellow, silty clay, firm, occasional small stones	50	2	
158	15802		cut	Ditch	Linear NE-SW. Steep edges with v-shaped base	>1	0.96	0.36
158	15803	15802	fill	Secondary Fill	Mid orange brown, sandy silt, friable, rare small rounded pebbles	>1	0.29	0.12
158	15804	15802	fill	Secondary Fill	Dark brown grey, silty clay, firm, occasional pebbles and rare charcoal flecks	>1	0.96	0.24
158	15805		cut	Pit	Circular in plan. Steep edges with concave base	0.66	0.66	0.14
158	15806	15805	fill	Deliberate Backfill	Dark brown grey, silty clay, firm, rare charcoal flecks and occasional small pebbles	0.66	0.66	0.14
158	15807		cut	Ditch	Linear NW-SE. Steep edges with unknown base	>1	1.5	>0.8
158	15808	15807	fill	Deliberate Backfill	Light yellow grey, silty clay, firm, frequent stones and occasional shells	>1	1.5	>0.8
158	15809		cut	Ditch	Linear NW-SE. Steep edges with concave base	>1	0.86	0.6
158	15810	15809	fill	Deliberate Backfill	Dark black, silty clay, firm, occasional charcoal flecks and stones	>1	0.86	0.6
158	15811		cut	Ditch	Linear NW-SE. Steep edges with concave base	>1	0.44	0.38
158	15812	15811	fill	Deliberate Backfill	Mid brown orange, sandy silt, friable, occasional small stones and charcoal flecks	>1	0.44	0.38
158	15813		cut	Ditch	Linear NW-SE. Steep edges with concave base	>1	0.4	0.21
158	15814	15813	fill	Deliberate Backfill	Light brown yellow, silty clay, firm, occasional small stones	>1	0.4	0.21
158	15815		cut	Ditch	Linear NW-SE. Steep edges with concave base	>1	0.79	0.44

158	15816	15815	fill	Deliberate Backfill	Light brown grey, silty clay, firm, occasional small stones and rare charcoal flecks	>1	0.79	0.44
159	15900		layer	Ploughsoil	Dark grey brown, silty clay, friable	50	2	0.25
159	15901		layer	Natural	Light brown yellow, silty clay, firm, frequent stones	50	2	
159	15902		cut	Ditch	Curvilinear E-W and NE-SE to SW. Steep edges with concave base	>1	0.44	0.33
159	15903	15902	fill	Secondary Fill	Mid brown red, silty clay, friable, occasional small stones	>1	0.44	0.33
159	15904		cut	Ditch	Linear N-S. Steep edges with concave base	>1	1.6	0.72
159	15905	15904	fill	Primary Fill	Light yellow brown, silty clay, firm, frequent stones	>1	0.64	0.36
159	15906	15904	fill	Deliberate Backfill	Dark grey black, silty clay, firm, frequent charcoal flecks	>1	0.74	0.14
159	15907	15904	fill	Secondary Fill	Dark brown grey, silty clay, firm, moderate small-medium stones	>1	1.6	0.45
159	15908		void					
159	15909		cut	Ditch	Linear NW-SE. Steep slopes with a flat base	>2.3	1.3	0.7
159	15910	15909	fill	Secondary Fill	Dark grey brown, silty clay, friable, frequent stones	>2.3	1.18	0.44
159	15911	15909	fill	Secondary Fill	Light grey brown, silty clay, friable, frequent sub-angular stones	>2.3	0.87	0.22
160	16000		layer	Ploughsoil	Dark greyish brown. Silty clay. Friable. Moderate small and medium sized stones as inclusions.	50	2	0.3
160	16001		layer	Natural	Light bluish yellow. Clayey silt. Compact. Occasionally sub-angular stones as inclusions.	50	2	
161	16100		layer	Ploughsoil	Dark greyish brown. Silty clay. Loose. Moderate small sub-rounded stones as inclusions.	50	2	0.25
161	16101		layer	Natural	Light whitish yellow. Clayey silt. Moderate small, medium and large stones (chalk, limestones and flint nodules as inclusions)	50	2	
161	16102		cut	Ditch	Linear running E-W, steep concave sides, concave base	>1	1.13	0.38
161	16103	16102	fill	Secondary Fill	Mid greyish-brown silty clay, firm. Occasional small-medium round/angular stones, rare charcoal	>1	1.13	0.38
162	16200		layer	Ploughsoil	Mid grey brown, silty clay, friable	50	2	0.3
162	16201		layer	Natural	Mid brown yellow, silty clay, firm, occasional stones	50	2	
162	16202		cut	Ditch	Linear E-W. Steep edges with concave base	>1	1.03	0.46
162	16203	16202	fill	Secondary Fill	Light grey brown, silty clay, firm, frequent large angular stones	>1	1.03	0.46
163	16300		layer	Ploughsoil	Dark greyish brown. Silty clay. Friable. Moderate small and medium sized stones as inclusions.	50	2	0.25
163	16301		layer	Natural	Mid yellowish brown. Clayey silt. Firm. Frequent angular and sub-angular limestones and chalk as inclusions.	50	2	
164	16400		layer	Ploughsoil	Dark greyish brown. Silty clay. Loose. Moderate sub-angular stones as inclusions.	50	2	0.35
164	16401		layer	Natural	Mid reddish brown. Bedrock comprising chalk. Compact.	50	2	
164	16402		cut	Ditch	E/W aligned, steep sides, concave base	>1.8	0.9	0.53

164	16403	16402	fill	Other Fill	Fill of ditch, mid orangey brown silty clay, friable	>1.8	0.9	0.53
166	16600		layer	Ploughsoil	Mid grey, brown, silty clay, friable	50	2	0.3
166	16601		layer	Subsoil	Light brown, silty clay, friable	50	2	0.3
166	16602		layer	Natural	Light yellow brown, silty clay with white chalk patches, friable, occasional limestones	50	2	
167	16700		layer	Ploughsoil	Mid grey, brown, silty clay, friable	50	2	0.25
167	16701		layer	Natural	Light brown, silty clay, friable	50	2	
167	16702		cut	Ditch	Linear running W-E, shallow sides, concave base	>1	0.7	0.09
167	16703	16702	fill	Secondary Fill	Mid grey-brown silty clay, compact. Rare limestone and flint.	>1	0.7	0.09
168	16800		layer	Ploughsoil	Mid grey, brown, silty clay, friable	50	2	0.3
168	16801		layer	Natural	Light brown, silty clay, friable	50	2	
169	16900		layer	Ploughsoil	Mid grey, brown, silty clay, friable	50	2	0.3
169	16901		layer	Natural	Light brown, silty clay, friable	50	2	
169	16902		cut	Pit	Circular, steep convex sides, flat base	0.4	0.4	0.12
169	16903	16902	fill	Secondary Fill	Pale pinkish-brown clayey silt, soft and plastic. Occasional charcoal, moderate burnt clay.	0.4	0.4	0.12
169	16904		cut	Tree Throw	Round and irregular, gradual irregular sides, irregular base	0.8	0.8	0.1
169	16905	16904	fill	Primary Fill	Dark brown silty clay, soft and sticky. Occasional charcoal.	0.8	0.8	0.1
170	17000		layer	Ploughsoil	Dark grey brown, silty clay, friable	50	2	0.3
170	17001		layer	Natural	Mid orange brown, silty clay and bedrock, compact,	50	2	
171	17100		layer	Ploughsoil	Mid grey, brown, silty clay, friable	50	2	0.25
171	17101		layer	Natural	Light brown, silty clay, friable	50	2	
171	17102		cut	Ditch	Cut to a shallow ditch, NE SW aligned, gentle to moderate sloping, flat base.	>1.8	1	0.19
171	17103	17102	fill	Other Fill	Fill of wide shallow ditch, dark brownish grey silty clay, friable with 10% stone and 1% charcoal inclusions	>1.8	1	0.19
172	17200		layer	Ploughsoil	Mid greyish brown. Silty clay. Loose. Moderate small sub-rounded stones as inclusions.	50	2	0.25
172	17201		layer	Natural	Light greyish brown. Clayey silt. Firm. Frequent angular limestone stones as inclusions.	50	2	
173	17300		layer	Ploughsoil	Mid grey, brown, silty clay, friable	50	2	0.25
173	17301		layer	Natural	Light brown, silty clay, friable	50	2	
174	17400		layer	Ploughsoil	Mid greyish brown. Silty clay. Friable. Moderate small sub-rounded stones as inclusions.	50	2	0.3
174	17401		layer	Natural	Light brownish grey. Firm. Occasionally sub-rounded stones as inclusions.	50	2	
175	17500		layer	Ploughsoil	Mid greyish brown. Silty clay. Loose. Moderate small sub-rounded stones as inclusions.	50	2	0.25
175	17501		layer	Natural	Light greyish brown. Clayey silt. Firm. Frequent angular limestone stones as inclusions.	50	2	
176	17600		layer	Ploughsoil	Mid greyish brown. Silty clay. Loose. Moderate small sub-rounded stones as inclusions.	50	2	0.25

176	17601		layer	Natural	Light greyish brown. Clayey silt. Firm. Frequent angular limestone stones as inclusions.	50	2	
176	17602		cut	Ditch	Cut to small linear ditch, N S aligned, moderate sloping on West side, moderate to steep sloping on Eastside, uneven base smooth BOS	>1	0.7	0.25
176	17603	17602	fill	Other Fill	Fill of small ditch, light orangey brown silty clay, friable with over 30% small to medium sub angular stones	>1	0.7	0.25
177	17700		layer	Ploughsoil	Mid grey, brown, silty clay, friable	50	2	0.28
177	17701		layer	Natural	Light brown, silty clay, friable	50	2	
177	17702		cut	Ditch	Linear N-S. Steep edges with flat base	>1	1.2	0.29
177	17703	17702	fill	Secondary Fill	Dark orange brown, silty clay, firm, frequent angular stones	>1	1.2	0.29
178	17800		layer	Ploughsoil	Dark greyish brown. Silty clay. Loose. Moderate small sub-rounded stones as inclusions.	50	2	0.25
178	17801		layer	Subsoil	Mid reddish brown. Silty clay. Firm. Occasionally sub-angular stones as inclusions.	50	2	0.25
178	17802		layer	Natural	Mid greyish yellow. Compact. Clayey silt. Frequent angular gravels and stones as inclusions.	50	2	
179	17900		layer	Ploughsoil	Mid grey brown, silty clay, friable	50	2	0.25
179	17901		layer	Natural	Limestone bedrock, comprising angular stones, slabs and flagstones.	50	2	
179	17902		void					
179	17903		cut	Ditch	Linear, e/w. Shallow sides, irregular base.	>1	1.3	0.24
179	17904	17903	fill	Secondary Fill	Mid brown firm silt. Frequent limestone.	>1	1.3	0.24
180	18000		layer	Ploughsoil	Mid grey, brown, silty clay, friable	50	2	0.25
180	18001		layer	Natural	Light brown, silty clay, friable	50	2	
181	18100		layer	Ploughsoil	Mid grey, brown, silty clay, friable	50	2	0.25
181	18101		layer	Natural	Light brown, silty clay, friable	50	2	
182	18200		layer	Ploughsoil	Mid grey, brown, silty clay, friable	50	2	0.25
182	18201		layer	Natural	Light brown, silty clay, friable	50	2	
182	18202		cut	Ditch	Linear, n/s. Steep straight sides. Base not reached due to high water table.	>1	0.9	0.24
182	18203	18202	fill	Secondary Fill	Mid greyish brown, friable silty clay. Moderate inclusions of stones (s-l).	>1	0.9	0.24
183	18300		layer	Ploughsoil	Mid brown silty clay plough soil	50	2	0.3
183	18301		layer	Natural	Creamish white limestone with patches of yellowish brown silty clay	50	2	
184	18400		layer	Ploughsoil	Mid brown silty clay plough soil	50	2	0.3
184	18401		layer	Natural	Creamish white limestone with patches of yellowish brown silty clay	50	2	
185	18500		layer	Ploughsoil	Mid brown silty clay plough soil	50	2	0.3
185	18501		layer	Natural	Creamish white limestone with patches of yellowish brown silty clay	50	2	
186	18600		layer	Ploughsoil	Mid brown silty clay plough soil	50	2	0.3

186	18601		layer	Natural	Creamish white limestone with patches of yellowish brown silty clay	50	2	
187	18700		layer	Ploughsoil	Mid greyish brown. Silty clay. Loose. Moderate small stones as inclusions.	50	2	0.25
187	18701		layer	Natural	Bedrock, comprising angular limestone stone, slabs and flagstones. Compact.	50	2	
188	18800		layer	Ploughsoil	Mid greyish brown. Silty clay. Loose. Moderate small stones as inclusions.	50	2	0.25
188	18801		layer	Natural	Bedrock, comprising angular limestone stone, slabs and flagstones. Compact.	50	2	
189	18900		layer	Ploughsoil	Mid greyish brown. Silty clay. Loose. Moderate small stones as inclusions.	50	2	0.25
189	18901		layer	Natural	Bedrock, comprising angular limestone stone, slabs and flagstones. Compact.	50	2	
190	19000		layer	Ploughsoil	Mid grey brown, silty clay, friable	50	2	0.25
190	19001		layer	Subsoil	Mid red brown, silty clay, friable	50	2	0.1
190	19002		layer	Natural	Mid orange yellow, silty clay and bedrock, friable,	50	2	
190	19003		cut	Ditch	Linear NE-SW. Steep edges with flat base	>1	1.09	0.26
190	19004	19003	fill	Secondary Fill	Dark brown grey, silty clay, friable, frequent stones	>1	1.09	0.26
190	19005		cut	Ditch	Linear NW-SE. Steep edges with concave base	>1	0.7	0.41
190	19006	19005	fill	Secondary Fill	Dark grey brown, silty clay, firm, frequent sub-angular stones	>1	0.7	0.41
190	19007		cut	Ditch	Linear NW-SE. Steep edges with unknown base	>1	1.31	0.32
190	19008	19007	fill	Secondary Fill	Dark brown grey, silty clay, firm, frequent angular stones	>1	1.31	0.32
191	19100		layer	Ploughsoil	Mid grey brown, silty clay, friable	50	2	0.24
191	19101		layer	Subsoil	Mid red brown, silty clay, friable	50	2	0.11
191	19102		layer	Natural	Mid orange yellow, silty clay and bedrock, friable	50	2	
192	19200		layer	Ploughsoil	Mid grey brown, silty clay, friable	50	2	0.26
192	19201		layer	Subsoil	Mid red brown, silty clay, friable	50	2	0.12
192	19202		layer	Natural	Mid orange yellow, silty clay and bedrock, friable	50	2	
192	19203		cut	Ditch	Linear running NW-SE. Steep sloping sides and flat base.	>2.37	0.6	0.29
192	19204	19203	fill	Secondary Fill	Mid reddish brown. Silty clay. Friable. Occasionally medium sized and angular limestone.	>2.37	0.6	0.29
193	19300		layer	Ploughsoil	Dark greyish brown. Silt clay. Loose. Occasionally small sub-angular stones as inclusions.	50	2	0.25
193	19301		layer	Natural	Limestone bedrock, comprising angular stones and slabs. Mid yellowish brown. Clayey silt. Compact.	50	2	
195	19500		layer	Ploughsoil	Mid grey, brown, silty clay, friable	50	2	0.2
195	19501		layer	Subsoil	Light brown, silty clay, friable	50	2	0.15
195	19502		layer	Natural	Limestone bedrock comprising angular stones and slabs. It has also patches of gravely bluish grey clayey silt. Compact.	50	2	
196	19600		layer	Ploughsoil	Mid grey brown, silty clay, friable	50	2	0.31
196	19601		layer	Natural	Mid orange yellow, silty clay with bedrock, firm	50	2	

196	19602		cut	Ditch	Linear E-W. Near vertical edges with flat base	>1	0.8	0.4
196	19603	19602	fill	Secondary Fill	Dark orange brown, clayey sand, firm, frequent large limestones	>1	0.8	0.4
196	19604		cut	Ditch	Linear N-S. Steep almost vertical sides and base not reached.	>1	2.71	0.77
196	19605	19604	fill	Deliberate Backfill	Mid red brown, sandy clay, friable. Stones (c. 5%, 20-250mm).	>1	2.71	0.77
197	19700		layer	Ploughsoil	Mid grey brown, silty clay, friable	50	2	0.3
197	19701		layer	Subsoil	Mid red brown, silty clay, friable	50	2	0.1
197	19702		layer	Natural	Mid orange yellow, clayey sand, friable, frequent stones	50	2	
197	19703		cut	Ring Ditch	Curvilinear, nw/se. Irregular sides, flat base.	>1	1.37	0.38
197	19704	19703	fill	Secondary Fill	Mid greyish brown, friable silty clay. Frequent stones (s-l).	>1	1.07	0.25
197	19705	19703	fill	Secondary Fill	Mid dark greyish brown, friable silty clay. Occasional stones (s).	>1	1.37	0.14
197	19706		cut	Poss. Ring ditch	Return of ditch 19703	>8	>2	
198	19800		layer	Ploughsoil	Mid grey brown, silty clay, friable	50	2	0.28
198	19801		layer	Subsoil	Mid red brown, silty clay, friable	50	2	0.1
198	19802		layer	Natural	Mid orange yellow, clayey sand, friable, frequent stones	50	2	
199	19900		layer	Ploughsoil	Mid grey brown, silty clay, friable	50	2	0.22
199	19901		layer	Subsoil	Mid red brown, silty clay, friable	50	2	0.1
199	19902		layer	Natural	Mid orange yellow, silty clay, friable, frequent stones	50	2	
200	20000		layer	Ploughsoil	Mid grey brown, silty clay, friable	50	2	0.3
200	20001		layer	Natural	Mid orange yellow, clayey sand, friable, frequent stones	50	2	
200	20002		cut	Modern	Linear N-S. Steep edges with field drain. No section	>1.9	1.12	0.75
200	20003	20002	fill	Deliberate Backfill	Dark brown grey, clayey sand with patches of redeposited natural, friable	>1.18	1.12	0.75
201	20100		layer	Ploughsoil	Mid grey brown, silty clay, friable	50	2	0.31
201	20101		layer	Natural	Mid orange brown, clayey sand, friable, frequent stones	50	2	
201	20102		cut	Ditch	Linear NW-SE, terminating towards the NW. Fairly steep edges with concave base	>1	0.42	0.22
201	20103	20102	fill	Secondary Fill	Mid orange brown, clayey sand, friable, frequent sub-angular stones	>1	0.42	0.22
202	20200		layer	Ploughsoil	Mid grey brown, silty clay, friable	50	2	0.32
202	20201		layer	Natural	Mid orange yellow, clayey sand, friable, frequent stones	50	2	
203	20300		layer	Ploughsoil	Mid grey brown, silty clay, friable	50	2	0.35
203	20301		layer	Natural	Mid orange yellow, clayey sand, friable, frequent stones	50	2	
203	20302		cut	Ditch	Linear NW-SE. Steep edges with concave base	>1	0.9	0.56
203	20303	20302	fill	Secondary Fill	Mid grey brown, clayey sand, friable, frequent stones	>1	0.9	0.56
203	20304		cut	Ditch	Linear NW-SE. Fairly gentle edges with concave base	>0.8	0.33	0.08
203	20305	20304	fill	Secondary Fill	Mid orange brown, clayey sand, friable, frequent stones	>0.8	0.33	0.08
203	20306		unexcavated feature	Linear feature	Linear NE-SW. Fill is mid orange brown, clayey sand, friable, frequent stones			
204	20400		layer	Ploughsoil	Mid grey brown, silty clay, friable	50	2	0.33

204	20401		layer	Natural	Mid orange yellow, clayey sand, friable, frequent stones	50	2	
204	20402		cut	Pit	Oval in plan. Steep edges with concave base	1.95	0.6	0.57
204	20403	20402	fill	Secondary Fill	Mid orange brown, clayey sand, friable, frequent stones	1.95	0.6	0.57
204	20404		cut	Pit	Oval in plan. Irregular sides and base	1.48	1.18	0.21
204	20405	20404	fill	Secondary Fill	Mid orange brown, sandy silt, friable	1.48	0.65	0.06
204	20406	20404	fill	Secondary Fill	Mid grey brown, clayey silt, compact, frequent stones	1.48	0.84	0.15
204	20407		cut	Ditch	Linear NW-SE. Moderate slopes with concave base	>1	1.86	0.53
204	20408	20407	fill	Secondary Fill	Mid grey brown, clayey silt, compact	>1	1.86	0.25
204	20409	20407	fill	Secondary Fill	Mid orange brown, sandy silt, friable	>1	1.61	0.29
205	20500		layer	Ploughsoil	Mid grey brown, silty clay, friable	50	2	0.34
205	20501		layer	Natural	Mid orange yellow, clayey sand, friable, frequent stones	50	2	
206	20600		layer	Ploughsoil	Mid grey brown, silty clay, friable	50	2	0.31
206	20601		layer	Natural	Mid orange yellow, clayey sand, friable, frequent stones	50	2	
207	20700		layer	Ploughsoil	Mid grey brown, silty clay, friable	50	2	0.32
207	20701		layer	Natural	Mid orange yellow, clayey sand, friable, frequent stones	50	2	
208	20800		layer	Ploughsoil	Mid grey brown, silty clay, friable	50	2	0.31
208	20801		layer	Natural	Mid orange yellow, clayey sand, friable, frequent stones	50	2	
209	20900		layer	Ploughsoil	Mid grey brown, silty clay, friable	50	2	0.45
209	20901		layer	Subsoil	Mid red brown, , silty clay, friable	50	2	0.1
209	20902		layer	Natural	Mid yellow brown with grey patches, silty clay, compact, frequent sub-rounded stones	50	2	
209	20903		cut	Posthole	Circular in plan. Steep concave sides with a fairly flat base.	0.25	0.25	0.18
209	20904	20903	fill	Post-pad	Light grey, silty clay firm, frequent large limestones	0.3	0.4	0.15
209	20905		fill	Secondary Fill	Dark grey, sandy silt, loose.	0.5	0.25	0.18
209	20906		cut	Posthole	Circular in plan. Steep edges with concave base	0.7	0.7	0.13
209	20907	20906	fill	Secondary Fill	Mid grey brown, silty clay, firm, frequent limestone	0.7	0.7	0.13
209	20908		cut	Posthole	Circular in plan. Steep edges with irregular base	0.61	0.49	0.21
209	20909	20908	fill	Secondary Fill	Dark grey brown, silty clay, soft, occasional stones	0.61	0.49	0.21
209	20910		cut	Ditch	Linear NW-SE. Moderate slopes with uneven base	>1.8	1.64	0.4
209	20911	20910	fill	Other Fill	Mid grey brown, silty clay, friable, frequent stones and rare charcoal flecks	>1.8	1.64	0.4
209	20912		cut	Posthole	Circular in plan. Steep edges with concave base	0.4	0.4	0.18
209	20913	20912	fill	Deliberate Backfill	Mid grey brown, silty clay, firm, frequent charcoal and stones	0.4	0.4	0.18
209	20914		cut	Posthole	Irregular in plan. Steep edges with concave base	0.4	0.4	0.18
209	20915	20914	fill	Deliberate Backfill	Mid grey brown, silty clay, firm, frequent charcoal and stones	0.4	0.4	0.18
209	20916		cut	Posthole	Circular in plan. Steep edges with concave base	0.2	0.2	0.18
209	20917	20916	fill	Deliberate Backfill	Dark grey brown, silty clay, firm, frequent stones	0.2	0.2	0.18
209	20918		cut	Ditch	Linear N-S. Steep edges with a concave base	>1.2	0.2	0.12

209	20919	20918	fill	Secondary Fill	Mid grey brown, silty clay, firm, rare charcoal flecks	>1.2	0.2	0.12
209	20920		cut	Construction Cut	Linear. Steep edges with flat base	>1.7	0.4	0.18
209	20921	20920	fill	Secondary Fill	Mid grey brown, silty clay, firm, frequent charcoal	>1.7	0.4	0.18
209	20922		cut	Ditch	Linear NE-SW. Steep edges with concave base	>1	0.7	0.42
209	20923		fill	Deliberate Backfill	Dark grey brown, sandy silt, loose, occasional limestones	>1	0.7	0.42
209	20924		cut	Posthole	Circular in plan. Fairly gentle edges with concave base	0.7	0.7	0.12
209	20925		fill	Secondary Fill	Light brown, sandy silt, loose, occasional large limestone	0.7	0.7	0.12
209	20926		cut	Ditch	Linear N-S. Moderate edges with concave base	>0.64	0.24	0.05
209	20927	20926	fill	Secondary Fill	Dark grey brown, silty clay, soft, occasional stones and charcoal	>0.64	0.24	0.05
209	20928		cut	Posthole	Circular in plan. Moderate edges with concave base	0.34	0.27	0.11
209	20929	20928	fill	Secondary Fill	Dark grey brown, silty clay, soft, occasional stones	0.34	0.27	0.11
209	20930		cut	Posthole	Circular in plan. Moderate slopes with concave base	0.55	0.49	0.2
209	20931		fill	Secondary Fill	Dark grey brown, silty clay, soft, moderate stones	0.55	0.49	0.2
209	20932		cut	Posthole	Sub circular, steep convex sides, concave base	0.46	0.24	0.2
209	20933	20932	fill	Secondary Fill	Mixed orange brown and pale grey brown. Friable silty sand. Limestone chunks.	0.46	0.24	0.2
209	20934		cut	Posthole	Sub-circular in plan. Steep sloping and slightly concave sides. Uneven base.	0.52	0.52	0.21
209	20935	20934	fill	Post-pad	Mid greyish brown. Silty clay. Friable. Frequent angular and sub-angular large and medium sized limestones.	0.52	0.52	0.21
209	20936		cut	Ditch	Ditch terminus cut by posthole. Linear, se/nw. Straight sides, irregular base.	>1.8	0.2	0.2
209	20937	20936	fill	Deliberate Backfill	Fill of ditch. Mid greyish brown firm silt. Moderate limestone.	>1.8	0.2	0.13
209	20938		cut	Posthole	Posthole cutting ditch. Circular with steep rounded sides.	0.4	0.4	0.2
209	20939	20938	fill	Deliberate Backfill	Mid grey brown firm silt. Frequent limestone.	0.4	0.4	0.2
209	20940		cut	Pit	Unknown shape in plan. Round cornered, steep sides, concave base.	0.5	0.8	0.3
209	20941	20940	fill	Deliberate Backfill	Pale brown silty clay, soft and sticky. Frequent large limestone pieces, occasional charcoal.	0.5	0.4	0.26
209	20942	20940	fill	Post-pipe	Dark brown silty clay, soft and sticky. Occasional charcoal.	>0.5	0.8	0.3
209	20943	20940	fill	Animal Bone Group	Dog burial - 90% complete.	0.5	0.3	0.2
209	20944		cut	Pit	Oval, rounded corners, gentle concave sides, rounded concave base.	0.9	0.6	0.12
209	20945	20944	fill	Deliberate Backfill	Pale brown silty clay, soft and sticky. Occasional charcoal	0.8	0.3	0.1
209	20946	20944	fill	Deliberate Backfill	Dark brown silty clay, soft and plastic. Occasional charcoal, frequent large limestone pieces	0.88	0.3	0.04
209	20947		cut	Posthole	Oval, concave sides, rounded concave base	1.2	0.6	0.35
209	20948	20947	fill	Deliberate Backfill	Pale brown silty clay, soft and plastic. Occasional charcoal pieces	1.2	0.3	0.2

209	20949	20947	fill	Deliberate Backfill	Dark brown silty clay, soft and plastic. Occasional charcoal, frequent large limestone pieces	1	0.3	0.1
-----	-------	-------	------	---------------------	---	---	-----	-----

APPENDIX B: THE FINDS

Table 1: Finds Concordance (Exc. pottery).

Context	Class	RA No.	Sample No.	Description	Fabric Code	Count	Weight (g)
504	Fired/burnt clay				fs	2	12
1200	Fired/burnt clay				fscpm	1	9
1213	Fired/burnt clay				fs/fssh	4	19
1306	Iron			Unidentified object		1	2
1308	Fired/burnt clay				ms	1	6
1311	Iron			Nail shank		1	6
1503	Fired/burnt clay			Daub	fssh/fscp	7	57
1508	Fired/burnt clay				fs/mscp	2	5
2314	Flint			Flake, blade		2	6
2705	Iron			Iron object		1	102
2707	Copper alloy			Crotal bell		5	22
4008	Fired/burnt clay				sh	3	9
4207	Flint			Flakes, bladelet		3	4
4217	Copper alloy	2		Coin		1	10
4226	Fired/burnt clay				fs	1	3
4226	Flint			Flake, blade		2	12
4226	Flint	1		Microdenticulate		1	9
4227	Burnt flint					1	6
4227	Fired/burnt clay				ms	1	5
4238	Flint			Flake		1	0.7
6304	Fired/burnt clay				fscp	1	3
7104	Industrial waste					6	351
7204	Iron			Nail		1	6
7212	Glass					1	20
7212	Iron			2 x nails, 1 x hook		3	74
9403	Iron			Nails		3	16
10203	CBM			Tile	fsfecp	1	30
11313	Iron			Nails		2	18
11319	CBM				ms	1	1
11321	CBM			Tile	fsfecp	1	18
11413	Copper alloy	3		Coin		1	2
11413	Fired/burnt clay				fscp	2	16
11413	Iron			Nails		7	47
11419	Iron			Nail		1	6
11604	Iron			Nail		1	9
11615	Iron		16	Hobnail		1	2
11906	Flint			Flake		1	2
11913	Fired/burnt clay				mscp	1	4
13605	Industrial waste					16	187
13704	CBM				fsc	1	1
14015	Iron			Nail		1	8
14016	Industrial waste					3	6
14205	Industrial waste					7	174
14205	Iron			Nail		1	8
14506	Glass					6	247
14506	Iron			Electrical wire?		9	229
14614	Iron			Nail		1	4

14704	Iron			Folding knife/penknife		1	30
14706	Iron			Nail		1	4
15907	Fired/burnt clay			Daub	fscpm	1	12
16403	CBM			Tile	ms	4	420
16903	Fired/burnt clay				ms/msc	6	25
19008	Industrial waste		43			1	9
20003	Glass					1	1
20905	Fired/burnt clay			Daub	fscpc	1	56
20923	Fired/burnt clay				fs/fscp/fscpc/fsl/ms/msc	23	134
20923	Iron	4		Blade		1	8
20931	CBM				fs	1	1
20939	Industrial waste					3	135
20942	Fired/burnt clay				fsc	1	63
20943	Fired/burnt clay			Daub	fscpc	1	12
20949	Fired/burnt clay				fs/fssh	4	81

Table 2: Summary of pottery by context.

ESMP22 Full Sherd Archive																		
Context	Fabric	Form	Rim	Body	Base	Decoration	Vessels	Alt	Drawing	Comments	Join	Sherd	Weight	Rim diam	Rim eve	Sample	Box no	
00103	CG1A	3	-	U	-	HM	1	ABR		BS; OX/R/OX		1	54	0	0		13	
00105	S1	-	-	U	-	HM	1	ABR		BS; OX/R/?		1	2	0	0		13	
00110	CG1A	-	-	U	-	HM	1	VAB		BS; IRF		1	1	0	0		13	
00110	CG1A	-	-	U	-	HM; COMB	1	ABR		BS; OX/R/OX; LATE LA TENE TYPE COMBING?		1	8	0	0		13	
00112	CG1A	-	-	U	-	HM; COMB	1	ABR		BS; OX/R/OX; LATE LA TENE TYPE COMBING		1	16	0	0		13	
00112	CG1A	-	-	U	-	HM	1	ABR		BS; IRF		1	26	0	0		13	
00112	CG1A	3B	BEAD	GLOB/OV	-	HM	1	ABR		RIM; R; CLARK 1999 FIG. 63.71		1	11	14	4		13	
00504	S1	-	-	U	-	HM	1	ABR		BS; OX/R; POORLY MIXED; ?EPH		1	1	0	0		13	
00804	C2	6	-	-	-	STRING	1	VAB		BASE		1	14	0	0		13	
00804	CG1	-	-	-	-	HM	1			BS; OX/R; ?DATE		1	8	0	0		13	
00804	CG1A	-	-	U	-		1			BS		1	7	0	0		13	
00804	CG3B	-	-	-	-		5			BS		5	39	0	0		13	
00804	GW2	9	-	-	-		1			BS; LOND TYPE FABRIC		1	2	0	0		13	
00804	CG3B	3M	-	-	-		1			RIM		1	4	14	6		13	
00804	CG1	-	-	-	-		4	ABR		BS		4	114	0	0		13	
00804	C2	50	-	-	-		1			RIM; DRAG 31 COPY		1	25	22	7		13	
00804	GW4	-	-	-	-		9	ABR		BS		9	90	0	0		13	
00804	GW2	9	-	-	-	COST	1	ABR	D02; P	BS SHLDR; ROWS OF DIAGONAL COMB STABS; LONDON WARE TYPE VESSEL & FABRIC; PHOTO ONLY		1	15	0	0		13	
00804	GW2	9J.1	-	-	-	COST	1		D01; P	BASE PEDESTAL FTG CARINATION; FORM BROADLY AS PERRIN 1999 FIG. 65.310?		2	57	0	0		13	
00804	GW4	3L.1	-	-	-	CORD	1			RIM NECK		4	55	20	12		13	
00804	GW4	-	-	-	-		1	PIERCED BASE		BASE FTG; PIERCED POST-FIRING 1.8MM DIA HOLE; ?DELIBERATE		1	174	0	0		13	
00804	GW4	-	-	-	-		1	VAB		BASE; CLSD		3	71	0	0		13	
00804	CG1	3	-	-	-		1			BASE		1	82	0	0		13	
00805	GW4	-	-	-	-		1			BS; ?UPPER NV OR LOCAL		1	7	0	0		13	
00805	CG3A	-	-	-	-		2			BS CLSD		2	20	0	0		13	
00805	CG3A	3M	-	-	-		1			RIM		1	17	18	9		13	

ESMP22 Full Sherd Archive																	
Context	Fabric	Form	Rim	Body	Base	Decoration	Vessels	Alt	Drawing	Comments	Join	Sherd	Weight	Rim diam	Rim eve	Sample	Box no
00904	C2	5	-	-	-		1			BS; NVGCC TYPE FABRIC; POSS DRAG 36 COPY		1	20	0	0		13
01200	CG1	-	-	-	-	HM	1	ABR		BASE; ?OXID; ?FTR OR CRUCIBLE RIM		1	6	0	0		01
01200	SW2	-	-	-	-		1	ABR		BS		1	2	0	0		01
01200	CG2	3	-	-	-	WM	1	ABR		RIM; LINCS FABRIC GYMS; TRANSITIONAL?		1	4	0	2		01
01200	CG	-	-	-	-		1	ABR		BS; OXID; THIN; ?POST ROMAN		1	5	0	0		01
01200	CG2	-	-	-	-		1			RIM		1	3	0	2		01
01200	CG2	-	-	-	-		5			BS		5	39	0	0		01
01200	CG1	3G.1	-	-	-	WM	1	ABR		RIM; OXID		1	23	14	18		01
01200	CG1	3L	-	-	-		1	ABR		RIM; R; LARGE NECKED JAR		1	45	34	6		01
01200	CG1	3M	-	-	-		1	VAB		RIM		1	54	0	0		01
01200	FCLAY	-	-	-	-		0	BURNT?		LIGHT FIRED ?OBJECT		2	24	0	0		10
01200	CG1	-	-	-	-		36	ABR		BS MISC		36	303	0	0		01
01200	CG1	3	-	-	-		1	ABR		BASE		1	45	0	0		01
01200	CG1	3	-	-	-		1	VAB		RIM; OXID		1	9	0	2		01
01213	CG	-	-	-	-		4			BS		4	63	0	0		01
01213	OW5	-	-	-	-		1	VAB		BS; ?DATE		1	1	0	0		01
01213	CG	3	-	-	-		1	ABR		RIM; ?DATE		1	4	0	2		01
01213	CG	3L	-	-	-		1	VAB		RIM; ?DATE		1	8	18	4		01
01213	CG	3M	-	-	-		1	VAB		RIM; ?DATE		1	10	22	6		01
01213	CG	-	-	-	-	WF; SHG	1			BS		1	47	0	0		01
01213	CG	-	-	-	-	WF; SHG	1			BS		1	12	0	0		01
01213	CG	-	-	-	-		28	ABR		BS MISC		28	156	0	0		01
01213	CG1	11F	-	-	-	HB/WF; PIERCED LOWER WALL	1		D03; P	RIM; KNIFE TRIMMED TOP; APPEARS TO BE A BOWL WITH PIERCED LOWER WALL PRE-FIRING; CF SAMUELS 1983 BOURNE KILN GROUP; MAY BE UNUSUAL POST-ROMAN FORM CHECK WITH SPECIALIST		1	38	18	7		01
01213	CG	3L	-	-	-		1	VAB		RIM; ?DATE		1	15	30	7		01
01300	EA	-	-	-	-		1			BS; BLACK GLAZED EARTHENWARE BOWL		1	28	0	0		01
01300	CG	3	-	-	-		1			BS		1	11	0	0		01
01305	CG1A	-	-	-	FLT	HM	1	VAB		BASE; IRF		10	40	0	0		01
01305	CG1A	-	-	U	-	HM	1	ABR		BS; OX/R		1	53	0	0		01
01308	CG1	-	-	-	-		1	VAB		BS; ?DATE		1	4	0	0		01
01308	GW	-	-	-	-		1	VAB		BS; ?DATE		1	9	0	0		01

ESMP22 Full Sherd Archive																	
Context	Fabric	Form	Rim	Body	Base	Decoration	Vessels	Alt	Drawing	Comments	Join	Sherd	Weight	Rim diam	Rim eve	Sample	Box no
01308	CG1A	3	EVR	-	-	HM	1	VAB		RIM; R		1	16	0	2		01
01311	GW5	-	-	-	-		1	ABR		BS		1	2	0	0		01
01311	GW3	-	-	-	-		2			BS		2	30	0	0		01
01311	CG1	-	-	-	-		8	ABR		BS		8	104	0	0		01
01311	CG1	3M	-	-	-		1	ABR		RIM		1	41	28	7		01
01311	CG2	-	-	-	-		10	ABR		BS		10	30	0	0		01
01311	CG2	3	-	-	-	WM	2	ABR		BASE; FLAT		2	47	0	0		01
01311	OW5	-	-	-	-		1	VAB		BS; LIGHT OXID; ?DATE		1	29	0	0		01
01317	SW1	3B	-	-	-		1	VAB		RIM; IRF		1	2	0	2		01
01317	CG2	-	-	-	-	HM?	1	ABR		BS; IRF		4	40	0	0		01
01317	CG2	-	-	-	-	HM?	1	VAB		BS; IRF		3	7	0	0		01
01500	CG1	-	-	-	-	HM	1	VAB		BS		1	16	0	0		01
01503	CG	-	-	-	-		1	VAB		BS		1	3	0	0		01
01503	GW5	-	-	-	-		1	ABR		BASE; CLSD; FLAT BASE ?DATE		1	3	0	0		01
01503	GW3	-	-	-	-		1	ABR		BS SCRAP		1	2	0	0		01
01503	OW5	-	-	-	-		1	ABR		BS; FINER FABRIC; PALE OXID EXT; ?DATE		1	3	0	0		01
01503	CG1	-	-	-	-	HM	1	VAB		BS; DENSE SHELL; ?DATE		9	77	0	0		01
01505	CG1	3	-	-	-		1	VAB		RIM; ?DATE		1	6	16	4		01
01505	CG1	-	-	-	-		1	ABR		BS		1	3	0	0		01
01505	GW	-	-	-	-		1	ABR		RIM; NARROW NECKED JAR/FLAGON/JUG?		1	3	6	11		01
01505	GW	-	-	-	-		2	ABR		BS; ?DATE		2	10	0	0		01
01505	OW5	-	-	-	-		1	ABR		BS; ?DATE		3	14	0	0		01
01505	CG1	3G	-	-	-		1	ABR		RIM		1	4	12	6		01
01505	CG1	3	-	-	-	ROUZ?	1			BS; R; ROUZ ON SHLDR		1	8	0	0		01
01505	CG1	3	-	-	-	SHG	1			BS; R; WM; NECKED JAR?		1	11	0	0		01
01505	CG1	-	-	-	-		2	ABR		BS OXID		2	34	0	0		01
01505	CG1	-	-	-	-		71	ABR		BS MISC; OXID; ?DATE		71	473	0	0		01
01505	CG1	3	-	-	-		1	ABR		BS SHLDR		2	5	0	0		01
01507	GW3	-	-	-	-		1	VAB		BS		1	3	0	0		01
01507	GW3	-	-	-	-	CORD	1			BS; DARK SURFACES; CORDONED AS SOME EARLY ROMAN EXAMPLES FROM ANCASTER		2	13	0	0		01
01507	CG1	-	-	-	-		17	ABR		BS		17	358	0	0		01

ESMP22 Full Sherd Archive																	
Context	Fabric	Form	Rim	Body	Base	Decoration	Vessels	Alt	Drawing	Comments	Join	Sherd	Weight	Rim diam	Rim eve	Sample	Box no
01507	GW3	6	-	-	-		1	ABR		RIM FLANGE		1	13	24	8		01
01507	GW3	-	-	-	-		1	DISC?		BASE FTR; TRIMMED TO 44MM DISC?		1	23	0	0		01
01507	GW4	-	-	-	-		1	VAB		BASE PEDESTAL; CLSD		5	24	0	0		01
01507	CG2	-	-	-	-		1	ABR		BS		1	7	0	0		01
01507	CG2	3	-	-	-		1	VAB		RIM		1	3	0	2		01
01507	CG1	3G	-	-	-		1	ABR		RIM		1	2	0	2		01
01507	CG1	3	-	-	-		1			RIM		1	8	20	5		01
01507	CG1	-	-	-	-		1			BASE; FLAT		1	44	0	0		01
01507	CG1	-	-	-	-		1			BASE PEDESTAL		2	36	0	0		01
01507	GW3	-	-	-	-		3	ABR		BS; DARK SURFACES		3	12	0	0		01
01507	SAM	-	-	-	-	MOULD	1			BS; TINY OVOLO SCRAP		1	1	0	0		01
01508	GW3	-	-	-	-		4	ABR		BS		4	7	0	0		01
01508	WW	-	-	-	-		1	ABR		BS SCRAP		1	1	0	0		01
01508	CG1	-	-	-	-		2	VAB		BASE		2	13	0	0		01
01508	CG1	-	-	-	-		26	ABR		BS		26	74	0	0		01
01508	GW5	-	-	-	-		1	VAB		BS SCRAP		1	1	0	0		01
02311	CG1	-	-	-	-	HM	1			BS; OXID		2	37	0	0		01
03005	SW3	-	-	U	-	HM	1			BS; BLACK SURFACE; ?TRANSITIONAL OR ESAX		1	6	0	0		01
03005	CG1	-	-	-	U	HM	1			BASE; BLACK FIRED; ?DATE		3	44	0	0		01
04008	S1	-	-	-	-	HM	20			BS		20	55	0	0		01
04008	S1	-	REI	U	-	HM	1			RIM; R; OVERSIZED LID OR JAR WITH SPLAYED RIM AS EXAMPLES FROM GRETTON CF JACKSON & KNIGHT 1985 FIG. 7.40		1	20	0	2		01
04008	G1	-	-	U	-	HM	1	CARBON DEP INT		BS; IRF		2	79	0	0		01
04008	S1	-	-	U	-	HM	1			BS; R; THIN WALLED		1	7	0	0		01
04008	G1	-	-	U	-	HM	6			BS; R		6	43	0	0		01
04008	G1	-	-	U	-	HM	1			BS; IRF		4	105	0	0		01
04008	S2	-	-	U	-	HM	1			BS; R; B EXT		5	29	0	0		01
04008	G1	3	FD	-	-	HM	1			RIM; IRF; LBA-EIA OR POST-ROMAN?		1	14	12	11		01
04008	S2	-	-	U	-	HM	1			BS; IRF		1	4	0	0		01
04214	IV	-	-	U	-	HM	1			BS; EPH?		1	2	0	0		01
04226	S1	-	-	U	-	HM	7			BS; IRF		7	24	0	0		01

ESMP22 Full Sherd Archive																	
Context	Fabric	Form	Rim	Body	Base	Decoration	Vessels	Alt	Drawing	Comments	Join	Sherd	Weight	Rim diam	Rim eve	Sample	Box no
04226	S1	3	RD	U	-	HM	1	CARBON DEP EXT		RIM; IRF; SLIGHTLY INTURNED RIM FORM	04227	1	6	0	2		01
04227	S1	3	RD	U	-	HM	1	CARBON DEP EXT		RIM; IRF; SLIGHTLY INTURNED RIM FORM	04226	1	3	0	2		01
04227	S1	-	-	U	-	HM	1	ABR		BS; IRF		2	3	0	0		01
04227	IV	-	-	U	-	HM	1	ABR		BS; IRF; EPH?		4	1	0	0		01
04234	CG2	-	-	-	-		3			BS; OXID		3	36	0	0		01
04408	IVCP	-	-	U	-	HM; INC	1	ABR		BS; OXID		1	1	0	0		01
04408	IVCP	-	-	U	-	HM; INC	1	ABR		BS; IRF		1	4	0	0		01
04408	IVCP	-	FPI	U	-	HM; INC	1	ABR		RIM; IRF; 'JAR' OR BOWL; DEEPLY INCISED LATTICE BELOW RIM; INCISED CHEVRON ON FLATTENED RIM TIP		1	11	0	2		01
04408	IVCP	-	-	U	-	HM; INC	1			BS; OX/R; THICK WALLED; COLLARED URN OR SIMILAR LARGE VESSEL?		5	20	0	0		01
04408	IVCP	-	FRE	-	-	HM; INC	1	ABR		RIM; OX/R; JAR OR BOWL WITH INCISED RIM TIP?		2	6	0	2		01
04412	IVCP	-	-	U	-	HM	1	ABR		BS; OX/R		1	1	0	0		01
04604	MS	-	-	-	-		1	VAB		BS; TRACES OF GREEN GLAZE; SPECIALIST ID NEEDED		1	1	0	0		01
04604	MSW	-	-	-	-		1			BS; MODERN STONEWARE		1	7	0	0		01
06304	CG1A	-	-	U	-	HM	7	ABR		BS; IRF		7	18	0	0		13
06304	CG2A	3	-	U	-	HM	1	ABR		BS; OX/R		5	75	0	0		13
06304	Q1	-	-	U	-	HM	1	VAB		BS; OX		2	23	0	0		13
10203	S1	-	-	U	-	HM	1	ABR		BS; OX/R/OX; POORLY MIXED EPH?		1	4	0	0		01
10303	OW5	3	-	-	-		1	ABR		RIM; OX/R/OX; PALE CORE ?DATE		1	10	0	2		01
11110	MSW	-	-	-	-		1			BS		1	23	0	0		01
11205	C2	-	-	-	-		1			BS; CLSD		2	11	0	0		10
11205	C2	4	-	-	-		1	VAB		RIM		1	22	22	11		10
11205	C2	6	-	-	-		1	ABR		BASE		1	58	0	0		10
11205	GW4	-	-	-	-	CORD	1			BS; CLSD		1	7	0	0		10
11205	CG1B	3M.2	-	-	-		1			RIM SHLDR; PROFILE AS CLARK 1999 FIG. 71.191		9	95	23	14		10
11205	CG1	-	-	-	-		1			BS		1	7	0	0		10
11207	C2	-	-	-	-		2			BS		2	32	0	0		10
11207	C2	4B.2	-	-	-		1			RIM NECK		1	20	20	4		10
11209	C2	-	-	-	-		1	BURNT; ABR		BS		1	3	0	0		10

ESMP22 Full Sherd Archive																	
Context	Fabric	Form	Rim	Body	Base	Decoration	Vessels	Alt	Drawing	Comments	Join	Sherd	Weight	Rim diam	Rim eve	Sample	Box no
11209	C2	-	-	-	-		1	VAB		BS; ALL SLIP LOST		1	2	0	0		10
11209	GW4	-	-	-	-		4	VAB		BS		4	42	0	0		10
11209	C11	-	-	-	-		1			BS; JAR OR BOWL		1	6	0	0		10
11304	CG2B	3M.2	-	-	-		1			RIM		1	5	20	3		10
11304	GW4	4	-	-	-		1			BS NECK SHLDR		1	24	0	0		10
11304	GW4	-	-	-	-		1	ABR		BS		2	22	0	0		10
11304	GW4	-	-	-	-		1	ABR		BS; SLIGHTLY SANDY		1	29	0	0		10
11304	GW3	3	-	-	-		1			RIM		1	13	22	7		10
11304	GW3	-	-	-	-		1			BS; CLSD		1	5	0	0		10
11304	BB1	6E.1	-	-	-		1			RIM		2	22	24	7		10
11310	CG1B	3	-	-	-		1			BASE		5	30	0	0		10
11313	C2	-	-	-	-		2	VAB		BS		2	8	0	0		10
11313	C2	6D	-	-	-		1	VAB		RIM; LINCS FORM CODE BFL		1	12	20	6		10
11313	C2	-	-	-	-		1	VAB		BASE		1	8	0	0		10
11313	GW4	-	-	-	-		3	ABR		BS		3	12	0	0		10
11313	GW4	-	-	-	-		1	ABR		BASE; CLSD		1	27	0	0		10
11313	GT1	3	-	-	-	WF?; CORD	1	ABR		BS NECK; TRANSITIONAL TYPE; OX/R/OX		1	73	0	0		10
11313	CG1B	3M.2	-	-	-		1			RIM NECK		1	42	14	14		10
11315	GW4	-	-	-	-		8	ABR		BS		8	45	0	0		10
11315	GW4	3	-	-	-		1	ABR		BASE		6	299	0	0		10
11315	GW4	4	-	-	-		1	ABR		RIM		1	33	20	16		10
11315	C3	3	-	-	-		1	ABR		RIM		1	10	16	9		10
11315	CG1B	-	-	-	-		1			BS; OXID		1	10	0	0		10
11315	CG1A	3	-	U	FLT	HM	1			BASE; R; SHELL & ?LIMESTONE		5	86	0	0		10
11319	C3	-	-	-	-		1	ABR		BS		3	3	0	0		10
11319	CG1	-	-	-	-		1	ABR		BS; OX/R		1	19	0	0		10
11319	GW4	4	-	-	-		1	ABR		RIM		1	11	20	7		10
11319	GW4	-	-	-	-		2	VAB		BS		2	8	0	0		10
11319	C2	9E.2	-	-	-		1	ABR		RIM		1	4	10	9		10
11319	C2	-	-	-	-		4	ABR		BS; JBL		4	47	0	0		10
11319	GW4	-	-	-	-		1	ABR		BASE		1	15	0	0		10

ESMP22 Full Sherd Archive																	
Context	Fabric	Form	Rim	Body	Base	Decoration	Vessels	Alt	Drawing	Comments	Join	Sherd	Weight	Rim diam	Rim eve	Sample	Box no
11321	C7	9	-	-	-	ROUZ	1			BS		1	1	0	0		10
11321	OW5	-	-	-	-		1	VAB		BS		1	4	0	0		10
11321	CG1	-	-	-	-	HM	1			BS; LARGE JAR/TANK/OVEN?		1	37	0	0		10
11321	GW4	6D.1	-	-	-		1	ABR		RIM; DROOPING		1	11	24	4		10
11325	S1	3	RD	GLOB	-	HM; SCR	1			RIM; IRF; FORM AS ELSDON 1996A D6.89 MACRETH (1988 WERRINGTON)		4	66	20	17		10
11325	S1	3	-	GLOB	-	HM; SCR	11			BS; IRF; MISC SCORED WARE		11	242	0	0		10
11325	S1	3	-	-	FLT	HM	1			BASE; IRF		1	21	0	0		10
11325	S1	-	-	U	-		8	VAB		BS & SCRAPS		8	23	0	0		10
11331	CG1B	3M.2	-	-	-		1			RIM		1	32	28	7		10
11331	GW4	-	-	-	-	CORD	1	ABR		BS		1	3	0	0		10
11409	IVCP	-	-	U	-		1	ABR		BS; OX/R/?; FLAKE		1	2	0	0		10
11413	CG1A	3	FEE	-	-	HM	1			RIM; IRF		1	10	14	7		10
11413	C3	1D.1	-	-	-		1	ABR		BS; DISC NECK HANDLE SCAR		1	28	0	0		10
11413	C2	4	-	-	-		1	ABR		RIM		1	10	24	5		10
11413	C2	3	-	-	-		1	VAB		RIM		1	7	0	2		10
11413	C2	6D	-	-	-		1	VAB		RIM; ROUNDED; AS GILLAM 225		1	8	24	4		10
11413	C2	6	-	-	-		1	ABR		BASE		1	33	0	0		10
11413	C2	-	-	-	-		1			BASE; CLSD		1	5	0	0		10
11413	C2	6D	-	-	-		1	BURNT		RIM		2	33	20	15		10
11413	C2	3	-	-	-		1	VAB		BASE		3	210	0	0		10
11413	SAM	-	-	-	-		1	VAB		BS		1	2	0	0		10
11413	SAMCG	-	-	-	-		1	VAB		BS		1	2	0	0		10
11413	SAMCG	B	-	-	-		1	VAB		RIM		1	4	20	4		10
11413	CG1B	-	-	-	-		13	ABR		BS		13	122	0	0		10
11413	CG1B	3	-	-	-		1	ABR		RIM; IRF		1	5	16	6		10
11413	CG1B	3L.2	-	-	-	WM	1			RIM; IRF; AS NORFOLK ST.264		2	19	16	12		10
11413	CG1B	3M.2	-	-	-		1			RIM; IRF		1	9	22	6		10
11413	CG1	3	-	-	-	WM	1			RIM; R		1	5	16	7		10
11413	CG1A	3	FEE	-	-	HM; SLASHED RIM	1			RIM; R		1	28	28	4		10
11413	CG1	-	-	-	-		1			BS; R		3	84	0	0		10

ESMP22 Full Sherd Archive																	
Context	Fabric	Form	Rim	Body	Base	Decoration	Vessels	Alt	Drawing	Comments	Join	Sherd	Weight	Rim diam	Rim eve	Sample	Box no
11413	MO	M	-	-	-		1	VAB		BS; PINK FABRIC; FCLAY TRITS; ?MANCETTER TYPE		1	8	0	0		10
11413	GT3A	3	-	-	-		1	ABR		BS; LARGE GLOBULAR JAR		2	66	0	0		10
11413	AM9A	A	-	-	-		1	ABR		BS; BUFF		1	23	0	0		10
11413	MO6	M	-	-	-		1	WORN INT		BS		1	22	0	0		10
11413	GW4	-	-	-	-		9			BS		9	76	0	0		10
11413	C2	3	-	-	-		1	BURNT; ABR		BS		1	33	0	0		10
11413	SAMCG	31	-	-	-		1			BASE FTR; KICK		3	42	0	0		10
11413	GW4	3	-	-	-		1	ABR		BASE		1	47	0	0		10
11413	C2	-	-	-	-		3			BS; OPEN		3	29	0	0		10
11413	GW3	3	-	-	-		1	BURNT; ABR		BS		1	37	0	0		10
11413	GW3	-	-	-	-		4	MUDDY		BS		4	24	0	0		10
11413	GW5	3M	-	-	-		1			RIM NECK		3	19	12	21		10
11413	BB1	6	-	-	-		1			BASE		3	24	0	0		10
11413	GW4	-	-	-	-		1	VAB		BS; NV/LOCAL		2	42	0	0		10
11413	GW4	3L	-	-	-	SHG	1			RIM SHLDR; FORM AS PERRIN 1999 FIG. 57.50		1	24	19	9		10
11413	GW4	4	-	-	-	CORD	1			RIM NECK; AS PERRIN 1999 FIG. 57.39		1	17	26	4		10
11413	FCLAY	-	-	-	-		0	ABR		BS; OXID; FCLAY OR VESSEL		1	7	0	0		10
11413	GW4	4	-	-	-		1	VAB		RIM		1	10	26	4		10
11413	C2	9F.1	-	-	-		1			RIM		1	4	10	11		10
11413	C2	-	-	-	-		8	ABR		BS		8	33	0	0		10
11413	C2	-	-	-	-		1	VAB		RIM		1	4	0	2		10
11413	GW4	6A	-	-	-		1			RIM; DEEP EXAMPLE AS PERRIN 1999 FIG. 58.89		3	35	20	17		10
11413	C2	9	-	-	-	ROU	1			BS		1	2	0	0		10
11413	GW4	6	-	-	-		1	ABR		BASE		2	38	0	0		10
11413	C2	7	-	-	-		1	ABR		BASE FTR		1	5	0	0		10
11413	C2	9	-	-	-	PA	1	ABR		BS		1	4	0	0		10
11413	C3	-	-	-	-		1	BURNT		BS; ?FABRIC		1	3	0	0		10
11413	C3	-	-	-	-	ROU	1			BS; CLSD		1	5	0	0		10
11413	C3	-	-	-	-		1			BASE FTG; CLSD		1	11	0	0		10
11413	C2	9	-	-	-		2			BS		2	5	0	0		10
11415	GW4	-	-	-	-		1	VAB		BS		1	25	0	0		10

ESMP22 Full Sherd Archive																	
Context	Fabric	Form	Rim	Body	Base	Decoration	Vessels	Alt	Drawing	Comments	Join	Sherd	Weight	Rim diam	Rim eve	Sample	Box no
11415	GW4	-	-	-	-		1			BS		1	5	0	0		10
11419	GW4	-	-	-	-		1	VAB		BS		1	4	0	0		10
11419	GW4	7C.1	-	-	-	BAVE	1			RIM; AS DANNELL 1973 AND PERRIN 1996 OHF NO. 267		2	28	26	7		10
11422	S1	-	-	U	-	HM; INC	1			BS; OX/R; INCISED LINES AND ZONES OF CHEVRONS/HERRINGBONE DECORATION; PROB BA BEAKER		2	23	0	0		10
11507	S1	-	-	U	-	HM	23	ABR		BS; IRF		23	249	0	0		10
11507	S1	-	-	-	U	HM	1	ABR		BS; R		1	12	0	0		10
11507	S1	3D.2	IC	-	-	HM	1	VAB		RIM; IRF		1	19	0	2		10
11507	S1	3	-	U	-	HM; SCR	3	ABR		BS; IRF		3	92	0	0		10
11511	S1	-	-	U	-	HM; SCR	1	ABR		BS; OX/R		1	16	0	0		10
11515	C2	-	-	-	-		1	ABR		BS		1	12	0	0		10
11515	C3	-	-	-	-		1	VAB		BS; PALE OXID; NEARLY ALL COLOUR COAT LOST		1	4	0	0		10
11515	GW5	5C.2	-	-	-		1			RIM; AS CLARK 1999 FIG. 77.298; LINCOLN FORM BWM3		1	118	38	7		10
11515	GW5	-	-	-	-		1	VAB		RIM		1	5	0	2		10
11515	GW4	-	-	-	-		3	VAB		BS		3	15	0	0		10
11515	CG1A	-	-	-	FLT		1	VAB		BASE		1	18	0	0		10
11515	CG1	-	-	-	-		1	ABR		BS SCRAP		1	1	0	0		10
11515	CG1	3L	-	-	-		1			RIM		1	11	24	4		10
11515	CG1	-	-	-	-		3			BS		3	27	0	0		10
11515	C3	-	-	-	-		2			BS		2	23	0	0		10
11515	C2	-	-	-	-	ROU	1			BS		1	4	0	0		10
11515	C2	-	-	-	-	ROUZ	1			BS		1	4	0	0		10
11515	C2	3M	-	-	-		1	VAB		RIM		1	11	22	6		10
11515	C2	5L	-	-	-		1	VAB		BS BODY FLANGE; B38		1	48	0	0		10
11515	C2	3M	-	-	-		1	VAB		RIM		1	12	18	6		10
11515	C2	6A.1	-	-	-		1	VAB		RIM		1	17	24	3		10
11515	C3	3M	-	-	-		1	VAB		RIM		1	8	18	7		10
11604	GW4	-	-	-	-		1	VAB		BS		1	6	0	0		10
11604	C2	-	-	-	-		1	VAB		BS		10	25	0	0		10
11604	GW4	6E.2	-	-	-		1			RIM BASE LOWER WALL FULL PROFILE; FORM AS PERRIN 1999 FIG. 59.114		5	216	24	28		10
11604	CG1B	-	-	-	-		1	ABR		BS		1	10	0	0		10

ESMP22 Full Sherd Archive																	
Context	Fabric	Form	Rim	Body	Base	Decoration	Vessels	Alt	Drawing	Comments	Join	Sherd	Weight	Rim diam	Rim eve	Sample	Box no
11604	CG1B	3L	-	-	-		1			RIM SHLDR		2	42	13	21		10
11604	C2	4B	-	-	-		1			RIM GIRTH		17	253	20	32		10
11604	GW4	-	-	-	-		1	VAB		BS; CLSD		1	24	0	0		10
11606	C3	-	-	-	-		2	VAB		BS; CLSD		2	8	0	0		10
11606	GW4	3M	-	-	-		1	VAB		RIM; ?JNN		1	12	16	8		10
11606	C3	-	-	-	-		1	VAB		BS; CLSD		3	37	0	0		10
11606	MO6	M	-	-	-		1	WORN INT		BS		1	17	0	0		10
11606	C2	-	-	-	-		5	ABR		BS		5	64	0	0		10
11611	CG1	-	-	-	-		3	VAB		BS; IRF		3	12	0	0		10
11615	CG1A	-	-	U	-	HM	1			BS; IRF		1	6	0	0		10
11616	C2	6	-	-	-		1	VAB		BASE		1	20	0	0		10
11706	GW	3M	-	-	-		1	VERY BURNT		RIM; ?FABRIC		1	7	18	4		10
11706	CG1	-	-	-	-		1	BURNT		BS		4	13	0	0		10
11709	S1	3B.1	BEAD	U	-	HM	1	CARBON DEP EXT		RIM; R; FORM AS POLLARD 1994 FIG. 54.75		2	24	22	8		10
11805	CG1A	-	-	U	-	HM	36			BS; IRF; MISC; ?NO OF VESSELS MAY BE ONLY 2 OR 3		36	160	0	0		10
11805	SW3	3M	BEAD	NJ	-	HM; B EXT	1	PIERCED NECK POST-FIRING	D06	RIM; R; 4MM PIERCED HOLE		1	26	18	9		10
11805	CG1A	3	TRIF	NJ	-	HM	1	ABR	D05	RIM; OXID; TRIANGULAR RIM ON SLIGHTLY NECKED VESSEL		3	105	28	12		10
11805	CG1A	3B.2	TRIF	GLOB	-	HM	1	EXCORIATED INT	D04	RIM; OXID	11808	1	78	30	4		10
11808	CG1A	-	-	U	-	HM	54	ABR		BS MISC & FLAKES; ?NO OF VESSELS		54	246	0	0		10
11808	CG1A	3	-	-	FLT	HM	1			BASE; IRF		1	43	0	0		10
11808	CG1A	3	U	-	-	HM	1	VAB		RIM; IRF		1	11	0	2		10
11808	CG1A	3	U	-	-	HM	1	VAB		RIM; IRF		1	7	0	2		10
11808	CG1A	3	U	U	-	HM	1	VAB		RIM SHLDR; IRF		1	15	0	2		10
11808	CG1A	3B.2	TRIF	GLOB	-	HM	1	EXCORIATED INT	D04	RIM; OXID	11805	2	69	30	9		10
11814	CG1A	-	-	U	-	HM	1			BS; OX/R		1	6	0	0		10
11904	CG1A	3	-	NJ	-	HM; COMB	1	CARBON DEP EXT		BS SHLDR; OX/R; COMB-DECORATED STORAGE JAR		1	42	0	0		10
11904	SW2	9J	-	CAR	-	WF; CORD	1			BS SANDY; SOME RARE SHELL		1	18	0	0		10

ESMP22 Full Sherd Archive																	
Context	Fabric	Form	Rim	Body	Base	Decoration	Vessels	Alt	Drawing	Comments	Join	Sherd	Weight	Rim diam	Rim eve	Sample	Box no
11906	CG1A	-	-	U	-	HM	1			BS; OXID		1	13	0	0		10
11906	SW2	-	-	U	-	WF	1			BS		1	2	0	0		10
11906	CG1A	3	-	U	-	HM; SCR	1	ABR		BS; IRF		1	8	0	0		10
11906	CG1A	3	-	U	-	HM; SCR	1	ABR		BS; OX/R		2	13	0	0		10
11906	CG1A	3	-	U	-	HM; SCR	1	ABR		BS; OX/R		1	31	0	0		10
11908	CG1A	-	-	U	-	HM	1	VAB		BS; OXID		2	13	0	0		10
11908	CG1A	-	-	U	-	HM	1			BS; R		1	2	0	0		10
11908	CG1A	-	-	U	-	HM	1	VAB		BS; OX/R		1	3	0	0		10
11908	CG1A	-	-	U	FTR	HM	1	ABR		BASE; R		3	26	0	0		10
11913	S1	3A	FD	-	-	HM	1	ABR		RIM; R		1	7	20	4		10
11913	S1	-	-	U	-	HM	2	ABR		BS; R		2	10	0	0		10
12004	S1	-	-	U	-	HM	1	ABR		BS SCRAPS		2	2	0	0		10
12111	S1	-	-	U	-	HM	2			BS; IRF		2	9	0	0		10
12303	IV	-	-	U	-	HM	1	VAB		BS; OX/R; THIN WALLED; BA BEAKER?		2	2	0	0		10
12706	S1	-	-	U	-	HM	1	ABR		BS; OX/R		1	1	0	0		10
12803	S1	-	-	U	-	HM	1	ABR		BS; OX/R; ?BA THIN WALLED SHERD		1	2	0	0		10
12903	S1	-	-	U	-	HM	1	ABR		BS; OX/R; ?BA THIN WALLED SHERD		1	1	0	0		10
13005	S1	3	BEAD	NJ	-	HM	1	VAB		RIM; IRF		1	3	0	2		10
13005	S1	-	-	U	-	HM	1	ABR		BS; OXID		1	8	0	0		10
13602	SW2	9	-	-	-	WM; ROUZ	1	BURNT?		BS; R; BUTT BEAKER?		1	10	0	0		10
13605	GW3	-	-	-	-		1	VAB		BS		2	4	0	0		10
13605	C2	9	-	-	-		1	BURNT		BS; SCALE & FOLDED?		1	1	0	0		10
14010	IVCP	-	-	U	-	HM	1	ABR		BS; OX/R		1	6	0	0		13
14104	CG1A	3M	EVR	NJ	-	HM; B EXT	1			RIM; R; IASHF		1	16	20	7		13
14104	CG1A	-	-	U	-	HM	1	ABR		BS; IRF		1	2	0	0		13
14304	MS	-	-	-	-		1	ABR		BS; OXID; SANDY WITH CALC INCLUSIONS		2	7	0	0		13
14405	IVCP	-	-	U	-	HM	1	ABR		BS; OX/R		2	15	0	0		13
14606	CG3B	-	-	-	-		1			BS		1	5	0	0		13
14614	MS	-	-	-	-		1	ABR		BS; REDUCED GREEN GLAZED		1	5	0	0		13
14614	MS	-	-	-	-		1	ABR		BS; TRACES OF GREEN GLAZE		1	4	0	0		13
15106	G1	3	RRE	U	-		1	VAB		RIM; OX/R/OX; POORLY MIXED; ?EPH		1	19	0	2		13

ESMP22 Full Sherd Archive																	
Context	Fabric	Form	Rim	Body	Base	Decoration	Vessels	Alt	Drawing	Comments	Join	Sherd	Weight	Rim diam	Rim eve	Sample	Box no
15806	WW4	-	-	-	-	-	1	ABR		BS; CR		1	3	0	0		13
15806	CG3B	-	-	-	-	-	1			BS; SLSHB		1	9	0	0		13
15808	WW2	-	-	-	-	-	1	ABR		BS; CR		1	4	0	0		13
15812	CG3B	-	-	-	-	-	1			BS; SLSHB		2	19	0	0		13
15814	GW4	-	-	-	-	-	1	VAB		BS; NVGW?		1	67	0	0		13
15816	CG1A	-	-	U	-	HM	1			BS; IASH; THICK SHERD		1	55	0	0		13
15905	CG1A	3A	RD	OV	-	HM	1			RIM; OXID; IASH		1	25	18	5		13
15905	CG1A	-	-	-	U	HM	1			BASE; OXID; IASH		1	18	0	0		13
15906	CG1A	-	-	U	-	HM	2			BS; IRF; IASH		3	67	0	0	31	13
15907	CG1A	-	-	U	-	HM	1			BS; OXID; IASH; LARGE VESSEL		8	347	0	0		13
15907	CG2A	4	BEAD	NJ/NB	-	HM; CORD	1			RIM; R; IASH3		1	21	20	4		13
15907	GT1	3M	BEAD	NJ	-	HM; CORD	1			RIM; R; IAGR		1	23	30	4		13
15910	GW4	-	-	-	-	-	3	ABR		BS; NVGW		3	28	0	0		13
15910	C2	-	-	-	-	SHG	1			BS; CLSD; CC1		1	7	0	0		13
15910	GW5	3	-	-	-	CORD	1			BS; GREY/DSSA		1	6	0	0		13
15910	GW4	-	-	-	-	-	1	ABR		BS; NVGW		4	16	0	0		13
15910	C3	6E.2	-	-	-	-	1			RIM; CC3		1	26	14	18		13
15910	C2	6D	-	-	-	-	1			RIM BASE; CC1		2	124	17	26		13
15910	C2	9	-	-	-	-	1			BS; CC1		1	2	0	0		13
15910	C2	9D	-	-	-	-	1			BASE PEDESTAL; CC1		2	32	0	0		13
16103	CG1A	-	-	U	-	HM	4	ABR		BS; IRF; IASH		4	23	0	0		13
17103	CG1A	-	-	U	-	HM	6			BS; IRF; IASH		6	100	0	0		13
17103	CG1A	3	EVT	U	-	HM	1			RIM; OX/R; THIN WALLED; IASH		1	6	14	4		13
17103	SW2	7	-	OPEN	FTR	WF	1	ABR		BASE FTR; OXID; IASA		1	21	0	0		13
19004	CG1A	-	-	U	-	HM	1			BS; OXID; IASH		1	36	0	0		13
19605	CG1A	-	-	U	-	HM	1			BS; OXID; IASH		2	19	0	0		13
20002	MSW	-	-	-	-	-	1			BS; TO SPECIALIST		1	110	0	0		13
20002	EA	-	-	-	-	-	1	ABR		BS; TO SPECIALIST		1	1	0	0		13
20002	EA	-	-	-	-	-	1	ABR		BS; WHITE GLAZE; TO SPECIALIST		1	1	0	0		13
20400	CG1A	-	-	U	-	HM	1			BS; R; IASH		4	14	0	0		13
20403	CG1A	-	-	U	-	HM	1	CARBON DEP INT		BS; R; IASH		8	134	0	0		13

ESMP22 Full Sherd Archive																	
Context	Fabric	Form	Rim	Body	Base	Decoration	Vessels	Alt	Drawing	Comments	Join	Sherd	Weight	Rim diam	Rim eve	Sample	Box no
20403	CG1A	3	FD	U	-	HM	1			RIM; R; IASH		5	32	0	2	38	13
20405	CG1A	-	-	U	-	HM	1			BS; R; IASH		5	81	0	0		13
20405	CG1A	-	-	U	-	HM	6			BS; IRF; IASH		6	44	0	0		13
20405	CG1A	-	-	U	-	HM	1			BS; IRF; IASH		1	17	0	0	36	13
20409	CG1A	-	-	U	-	HM	3			BS; IRF; IASH		3	19	0	0		13
20900	C3	-	-	-	-		1	VAB		BS; LINC3 - CC3; CLSD FORM		1	17	0	0		13
20900	GW5	-	-	-	-		1			BASE; LINC3 CODE GREY		1	17	0	0		13
20900	GW5	-	-	-	-		1	BURNT OVER BREAK		BASE; LINC3 CODE GREY		1	18	0	0		13
20900	GW5	3	-	-	-		1			BASE; LINC3 CODE GREY		16	348	0	0		13
20900	C2	-	-	-	-		1			BS; LINC3 - CC1; CLSD FORM		1	41	0	0		13
20900	CG3B	3	-	-	-		1	ABR		BS; SLSHB		1	11	0	0		13
20900	CG1A	-	-	U	-	HM	1			BS; OX/R; IASH		1	53	0	0		13
20900	CG1B	3	-	-	-		1			BASE; OXID; SHELP		1	268	0	0		13
20900	GW5	3	-	-	-	SHG	1			BS SHLDR; LINC3 CODE GREY		1	26	0	0		13
20905	SW2	4	-	CAR	-	WF	1			BS; R; CARINATED VESSEL; LINC3 CODE IASA		1	11	0	0		13
20905	SW2	-	-	U	-	WF	1			BS; LINC3 CODE IASA		1	4	0	0		13
20905	CG1A	3M	BEAD	NJ	-	WF	1			RIM; LINC3 CODE IASH		2	21	16	4		13
20905	CG1A	-	-	U	-	WF	1			BS; LINC3 CODE IASH		3	75	0	0		13
20909	CG1A	-	-	U	-	HM	1			BS; LINC3 CODE IASH		1	11	0	0		13
20911	GW6	-	-	-	-		1	ABR		BS; LINC3 CODE GREY		1	3	0	0		13
20911	CG	-	-	-	-		1			BS; THIN WALLED; ?DATE; ?CG3B; LINC3 CODE SHEL		1	6	0	0		13
20911	GW4	-	-	-	-		1	ABR		BS; CLSD; LINC3 CODE NVGW?		1	12	0	0		13
20911	GW5	3	-	-	-		1			BASE; LINC3 CODE GREY		6	40	0	0		13
20911	MO6	M	-	-	-		1	WORN INT		BS; LINC3 CODE MONV; FABRIC AS D&P P198 LRF18 LATE NV FABRIC		1	26	0	0		13
20911	CG1B	-	-	-	-		1			BS; LINC3 CODE SHELP		1	12	0	0		13
20911	CG1A	-	-	U	-	HM; COMB	2			BS; LINC3 CODE IASH		2	19	0	0		13
20911	CG1A	-	-	U	-	HM	3			BS; LINC3 CODE IASH		3	46	0	0		13
20911	GW5	-	-	-	-		1			BS; LINC3 CODE GREY		2	12	0	0		13
20913	CG1A	-	-	U	-	HM	2	ABR		BS; IRF; LINC3 CODE IASH		2	14	0	0	30	13
20913	GT2	5D.2	BEAD	CAR	-	HM; CORD	1		D07	RIM; OX/R/OX; LINC3 CODE IAGROG; AS JACKSON & DIX 1987 FIG. 39.144-5; FOR LATER EXAMPLES CF JOHNSON 2009B FIG. 17.22		3	147	19	16		13

ESMP22 Full Sherd Archive																	
Context	Fabric	Form	Rim	Body	Base	Decoration	Vessels	Alt	Drawing	Comments	Join	Sherd	Weight	Rim diam	Rim eve	Sample	Box no
20915	CG1A	-	-	U	-	HM	1	ABR		BS; OX/R/OX; LINCS CODE IASH		1	16	0	0		13
20919	CG1A	3	FD	-	-	HM	1			RIM; R; LINCS CODE IASH		1	16	0	2		13
20921	CG2A	-	-	U	-	HM	1	VAB		BS; R?; LINCS CODE IASH		1	20	0	0		13
20921	CG1A	-	-	U	-	HM	1			BS; IRF; LINCS CODE IASH		1	3	0	0		13
20923	SW2	-	-	U	-	WF	1	BURNT; ABR		BS; R; LINCS CODE IASA		1	23	0	0		13
20923	GT2	-	RD	-	-	HM	1	ABR		RIM; OXID; NECKED JAR?; LINCS CODE IAGROG		1	4	0	2	29	13
20923	CG1A	3	RRE	-	-	HM	1	ABR		RIM; OXID; LINCS CODE IASH		1	9	0	2	29	13
20923	SW2	4	-	NJ/NB	-	WF; CORD	1			BS; R; LINCS CODE IASA		2	5	0	0		13
20923	CG1A	-	-	U	-	HM	5	ABR		BS; IRF; LINCS CODE IASH		5	28	0	0	29	13
20923	CG1A	3F	EVT	-	-	HM	1			RIM; R; LINCS CODE IASH		1	14	10	12		13
20923	CG1A	3M	BEAD	NJ	-	HM	1	ABR		RIM; OXID; LINCS CODE IASH; NECKED JAR OR BEAKER		3	17	14	17		13
20923	CG1A	-	-	-	FLT	HM	3	ABR		BASE MISC; LINCS CODE IASH		3	17	0	0		13
20923	CG1A	3	-	OV	FLT	HM	1			BASE; OXID; LINCS CODE IASH		24	740	0	0		13
20923	CG1A	3B	BEAD	OV	-	HM	1		D09	RIM SHLDR; R; LINCS FABRIC IASH; FORM AS JACKSON & DIX 1987 FIG. 39.136 UNDECORATED		1	59	18	14		13
20923	CG1A	3B	BEAD	OV	-	HM; RILL	1		D08	RIM; R; LINCS CODE IASH; FORM AS JACKSON & DIX 1987 FIG. 21.9		3	63	10	33		13
20923	GT2	5D.2	BEAD	CAR	-	HM; CORD	1	ABR		RIM; OX/R/OX; LINCS CODE IAGROG; AS JACKSON & DIX 1987 FIG. 39.144-5; FOR LATER EXAMPLES CF JOHNSON 2009B FIG. 17.22; AS D07 BUT THINNER WALLED		4	60	19	11		13
20923	CG1A	-	-	U	-	HM/WF	9	ABR		BS MISC; LINCS CODE IASH		9	132	0	0		13
20927	CG1A	3	-	U	FLT	HM	1	ABR		BASE; OXID; LINCS CODE IASH		2	155	0	0		13
20927	CG1A	-	-	U	-	HM	1			BS; OXID; LINCS CODE IASH		1	71	0	0		13
20927	GW5	-	-	-	-		1	ABR		BS; LINCS CODE GREY		2	32	0	0		13
20937	SAM	-	-	-	-		1	ABR		BS; SAMCG?		1	2	0	0		13
20937	CG1A	-	-	U	-	HM; COMB	1			BS; R; LINCS CODE IASH		1	7	0	0		13
20942	GW5	4A	-	-	-	SHG	1	ABR		BS; SOME RARE SHELL; LINCS CODE GREY (GYMS)		3	59	0	0		13
20942	CG1A	-	-	U	-	HM	7			BS; IRF; LINCS CODE IASH		7	41	0	0		13
20942	CG1A	-	-	U	-	HM	1			BS; IRF; LINCS CODE IASH		2	23	0	0		13
20942	CG1A	-	-	U	-	HM; RILL	1	ABR		BS; IRF; LINCS CODE IASH		1	30	0	0		13
20942	CG1A	3	-	NJ	-	HM	1	ABR		BS NECK; LINCS CODE IASH		1	23	0	0		13
20942	CG1A	3G	EVR	U	-	HM	1			RIM; IRF; LINCS CODE IASH		1	13	14	8		13
20942	CG2A	-	-	U	-	HM	1			BS; IRF; LINCS CODE IASH		1	20	0	0		13

ESMP22 Full Sherd Archive																	
Context	Fabric	Form	Rim	Body	Base	Decoration	Vessels	Alt	Drawing	Comments	Join	Sherd	Weight	Rim diam	Rim eve	Sample	Box no
20943	SW2	-	-	U	-	HM	1	ABR		BS; R; LINC CODE IASA		1	3	0	0	34	13
20943	CG1A	-	-	U	-	HM	1	ABR		BS; IRF; LINC CODE IASH		1	3	0	0	34	13
20943	CG1A	-	-	U	-	HM	1	CARBON DEP INT		BS; OX/R; LINC CODE IASH		2	37	0	0		13
20945	CG1	-	-	U	-	HM	1			BS; OX/R; ?DATE IA/ROMAN; LINC CODE SHEL		1	28	0	0	34	13
20946	CG1A	-	-	U	-	HM	5	ABR		BS; IRF; LINC CODE IASH		5	79	0	0		13
20946	CG1A	-	-	U	-	HM	1	VAB		BS; OX/R; SOME GROG; LINC CODE IASH		1	10	0	0		13
20946	CG2A	-	-	U	-	HM	1	ABR		BS; OX/R; LINC CODE IASH		1	24	0	0		13
20946	SW2	-	-	U	-	HM	1	BURNT?		BS; OX/R/OX; LINC CODE IASA		1	6	0	0		13
20949	CG1A	-	-	U	-	HM	4	ABR		BS; IRF; LINC CODE IASH		4	41	0	0		13
20949	SW2	-	-	U	-	HM	1	VAB		BS; IRF; LINC CODE IASA		1	5	0	0		13
20949	CG1A	3B	BEAD	OV	-	HM; RILL	1	CARBON DEP EXT	D10	RIM SHLDR; IRF; AS JACKSON & DIX 1987 FIG. 21.9		26	703	17	89		13

Table 3: Summary of spot dates from pottery.

ESMP22 Dating Summary								
Trench	Context	F No	F Type	Spot date	Comments	Sherd	Weight (g)	Total RE %
001	00103	00102	Ditch	Prehistoric to Roman	A single handmade shell-gritted sherd.	1	54	0
001	00105	00104	Ditch	Earlier Prehistoric	A single handmade sherd.	1	2	0
001	00110	00109	Ring Gully	Prehistoric	Two vesicular sherds, one with combed or incised lines.	2	9	0
001	00112	00111	Ditch	Late Iron Age	Sherds from a jar with a bead rim and another sherd with combed decoration.	3	53	4
005	00504	00503	Pit	Prehistoric	A single vesicular handmade sherd.	1	1	0
008	00804	00803	Ditch	3C	Nene Valley type grey ware, a sherd from a colour-coated bowl, fine grey ware with comb-stabbed decoration, and shell-gritted sherds.	36	757	25
008	00805	00803	Ditch	2-3C	A fine grey ware sherd and sherds from a Bourne type shell-gritted jar.	4	44	9
009	00904	00903	Ditch	3C	A sherd from a Nene Valley type grey colour-coated bowl.	1	20	0
012	01200	01200	Layer	Late Iron Age to Roman	A medium sized group of shell-gritted sherds including large necked jars, a jar with an everted rim and another with a flat base. No obvious wheel-made Roman sherds were noted although the group may date to the Early Roman period. A small group of fired clay was also present.	53	562	30
012	01213	01212	Pit	Late Iron Age to Early Roman?	A medium sized group of exclusively shell-gritted sherds. Necked jars present would fit a Late Iron Age to Early Roman date; an open form with a pre-firing piercing in the lower wall was unusual and difficult to parallel. This whole assemblage should be checked by a post-Roman pottery specialist.	40	354	26
013	01300	01300	Layer	Modern	A single modern black-glazed sherd and a shell-gritted sherd of Iron Age or Roman date.	2	39	0
013	01305	01304	Ditch	Iron Age to Roman	A small group of handmade shell-gritted sherds including flat basal fragments.	11	93	0
013	01308	01307	Ditch	Roman?	A small group including the rim from a shell-gritted jar, and a quartz sand gritted reduced ware sherd. This group should be checked by a post-Roman pottery specialist.	3	29	2
013	01311	01311	Floor surface	Roman	A medium sized group including shell-gritted necked jars and a fragment from a flat base, grey ware, and an oxidised sherd from a large vessel.	25	283	7
013	01317	01316	Ditch	Iron Age to Early Roman	A small group of handmade shell-gritted sherds.	8	49	2
015	01500	01500	Layer	Late Iron Age to Roman	A single shell-gritted sherd.	1	16	0

ESMP22 Dating Summary								
Trench	Context	F No	F Type	Spot date	Comments	Sherd	Weight (g)	Total RE %
015	01503	01502	Pit	Roman?	A small group including a sherd from a jar with a flat base and a range of densely shell-gritted sherds possibly of post-Roman date.	13	88	0
015	01505	01504	Pit	Roman?	A large group of mostly featureless shell-gritted body sherds. Some wheelmade sand-gritted sherds were present but the whole assemblage should be checked by a post-Roman pottery specialist.	86	571	21
015	01507	01506	Ditch	Roman	A medium sized group including samian, grey ware, possible colour-coated sherds and shell-gritted sherds.	38	547	17
015	01508	01506	Ditch	Roman	A medium sized group including grey ware and shell-gritted sherds.	34	96	0
023	02311	02308	Ditch	Prehistoric?	Handmade shell-gritted sherds from a single vessel. Should be checked by a post-Roman pottery specialist.	2	37	0
030	03005	03004	Ditch	Prehistoric?	Handmade shell-gritted sherds from a single vessel. Should be checked by a post-Roman pottery specialist.	4	50	0
040	04008	04007	Pit	Prehistoric or Post-Roman?	A medium sized group mostly consisting of shell-gritted sherds, the only feature sherd present was a knife-trimmed necked jar possibly dating to the late Bronze Age to Early Iron Age or Saxon Period. Should be checked by a post-Roman pottery specialist.	41	356	13
042	04214	04208	Ring Ditch	Early Prehistoric	A single vesicular Early Prehistoric sherd.	1	2	0
042	04226	04220	Ring Ditch	Prehistoric?	A small group of handmade shell-gritted sherds including a tiny rim fragment. Should be checked by a post-Roman pottery specialist.	8	30	2
042	04227	04220	Ring Ditch	Prehistoric?	A small group of handmade sherds, one rim fragment joined the vessel in 04226. Two other small vesicular fragments were probably of Earlier Prehistoric date. The rim fragment should be checked by a post-Roman pottery specialist.	7	7	2
042	04234	04233	Ditch	Iron Age?	A small group of handmade shell-gritted sherds. Should be checked by a post-Roman pottery specialist.	3	36	0
044	04408	04407	Pit	Late Neolithic to Early-Mid Bronze Age	A small group of incised ware sherds.	10	42	4
044	04412	04411	Pit	Early Prehistoric	A single vesicular Early Prehistoric sherd.	1	1	0
046	04604	?		Modern	A modern stoneware sherd and a green-glazed medieval sherd.	2	8	0
063	06304	06303	Pit	Prehistoric?	A small group including shell-gritted sherds. Should be checked by a post-Roman pottery specialist.	14	116	0
102	10203	10202	Ditch	Early Prehistoric	Small handmade sherds.	1	4	0

ESMP22 Dating Summary								
Trench	Context	F No	F Type	Spot date	Comments	Sherd	Weight (g)	Total RE %
103	10303	10302	Ditch	Roman?	A single heavily abraded oxidised rim sherd of Roman or perhaps medieval date.	1	10	2
111	11110	11106	Ditch	Modern	A single modern glazed sherd.	1	23	0
112	11205	11203	Ditch	L3-4	A small group including a grey ware sherd, a shell-gritted necked jar with a triangular rim, and colour-coated sherds including a bowl or dish and a necked jar or bowl.	15	200	25
112	11207	11206	Ditch	L3-4	A small group of colour-coated sherds including the rim from a necked bowl.	3	52	4
112	11209	11208	Pit	3-4C	A small group including Nene Valley grey ware and colour-coated sherds.	7	53	0
113	11304	11303	Ditch	3C	A small group including a sherd from a Black Burnished ware 1 bowl with a grooved flange (6E.1), Nene Valley grey ware including a necked jar or bowl (4) and a sherd from a shell-gritted jar.	9	120	17
113	11310	11309	Pit	Roman?	Shell-gritted sherds from a single vessel, probably of Roman date.	5	30	0
113	11313	11311	Ditch	L3-4	A small group including sherds from a colour-coated lipped bowl, Nene Valley grey ware and a shell-gritted narrow necked jar. The context also contained a grog-gritted sherd from a necked jar with cordoned decoration that probably dated to the 2nd century AD or earlier.	10	182	20
113	11315	11314	Post hole	3C	A small group including sherds from Nene Valley grey ware jars, a colour-coated necked jar, a shell-gritted sherd in an oxidised South Midlands type fabric and sherds from a handmade shell-gritted jar.	22	483	25
113	11319	11318	Ditch	L2-4	A small group including Nene Valley grey ware, colour-coated sherds including the rim from a necked jar or beaker and a shell-gritted sherd.	13	107	16
113	11321	11320	Ditch	3-4C	A small group including a sherd from a colour-coated beaker, a Nene Valley grey ware lipped bowl and a sherd from a large shell-gritted vessel.	4	53	4
113	11325	11324	Ditch	Mid to Late Iron Age	A small group of Scored ware shell-gritted sherds. One vessel had a plain rounded upright rim with a globular body.	24	352	17
113	11331	11330	Ditch	3-4C	A small group including Nene Valley grey ware and a shell-gritted rim from a necked jar with an under-cut rim, probably of late Roman date.	2	35	7
114	11409	11406	Ditch	Early Prehistoric	A single handmade sherd.	1	2	0

ESMP22 Dating Summary								
Trench	Context	F No	F Type	Spot date	Comments	Sherd	Weight (g)	Total RE %
114	11413	11406	Ditch	3-4C	A large group including samian, a Nene Valley type mortarium, a pink grog-gritted storage jar, Dressel 20 amphora and a range of shell-gritted sherds notably a channel-rimmed jar. Nene Valley grey ware was well represented including a necked jar or bowl and plain rimmed dishes. Nene Valley type colour-coated wares included a disc-necked flagon, jars, a lipped bowl and a funnel necked beaker. This group probably dated to the late 3rd to 4th century AD but included some earlier material including a fragment of fired clay or Earlier Prehistoric pottery.	99	1323	140
114	11415	11414	Ditch	M2-3	A small group of Nene Valley grey ware.	2	30	0
114	11419	11418	Ditch	3C	A small group including shell-gritted sherds and a Nene Valley grey ware bowl with barbotine decoration mimicking samian form Drag. 36.	3	32	7
114	11422	11421	Pit	Bronze Age?	Two shell-gritted sherds with incised decoration, one with a zone of chevron patterning.	2	23	0
115	11507	11505	Ditch	Mid Iron Age	A medium sized group of handmade shell-gritted wares. One possible Scored ware sherd and a fragment from a jar with a slashed rim (Nicholson et al 2006, Fig. 7.1 or 13) were the only diagnostic feature sherds present.	28	372	2
115	11511	11510	Ditch	Mid to late Iron Age	A single Scored ware sherd.	1	16	0
115	11515	11514	Ditch	3-4C	A medium sized group including a sherd from grey ware wide-mouthed bowl or necked jar with an undercut rim and handmade sherds possibly of Iron Age and Roman date. Nene Valley wares present included a hemispherical flanged bowl, necked jars or bowls and a plain rimmed dish. An additional oxidised sherd was also received.	22	338	35
116	11604	11603	Ditch	3-4C	A medium sized group including sherds from a Nene Valley grey ware bowl with a grooved flange (6E.2), Nene Valley type colour-coated ware sherds from a necked jar, and bowls and shell-gritted ware including a necked jar with a squared off rim.	37	576	81
116	11606	11603	Ditch	3-4C	A small group of Nene Valley type colour-coated sherds and a Nene Valley slag-gritted mortarium.	12	138	8
116	11611	11609	Pit	Iron Age or Roman	Small shell-gritted sherds.	3	12	0
116	11615	11612	Ditch	Roman?	A single shell-gritted sherd, possibly of later Roman date.	1	6	0

ESMP22 Dating Summary								
Trench	Context	F No	F Type	Spot date	Comments	Sherd	Weight (g)	Total RE %
116	11616	11612	Ditch	3-4C	A single colour-coated sherd.	1	20	0
117	11706	11705	Ditch	Roman	Grey ware and small shell-gritted sherds.	5	20	4
117	11709	11708	Ditch	Iron Age?	A single shell-gritted rim sherd of Iron Age or possibly middle Saxon date. This sherd should be checked by a local post-Roman pottery specialist.	2	24	8
118	11805	11803	Ditch	Late Iron Age	A medium sized group including sherds from shell-gritted jars one of which joins a vessel in context 11808, and a sherd from a sand-gritted necked jar with post-firing holes pierced in the neck. The latter jar suggests a Late Iron Age or 1st century AD date. Careful re-packing needed due to fragile state of the pottery.	41	369	25
118	11808	11806	Ditch	Iron Age?	An abundance of flaky handmade shell-gritted sherds including a rim that joins a vessel in context 11805. The rim fragment and a flattened base suggest an Iron Age date. Careful re-packing needed due to fragile state of the pottery.	60	391	15
118	11814	11812	Ditch	Iron Age?	A single handmade shell-gritted sherd.	1	6	0
119	11904	11903	Ditch	1C	A sherd from a large shell-gritted storage jar with combed decoration, and a wheel-made carinated bowl with cordon decoration of transitional or Early Roman date.	2	60	0
119	11906	11905	Ditch	Late Iron Age to Early Roman	A small group of shell-gritted sherds, most with combed decoration.	6	67	0
119	11908	11907	Ditch	Late Iron Age	A small group of shell-gritted sherds including a fragment from a vessel with a pedestal base.	7	44	0
119	11913	11912	Pit	Iron Age?	A small group of shell-gritted sherds, including a jar with an intumed rim. This context should be checked by a local post-Roman pottery specialist.	3	17	4
120	12004	12003	Ditch	Prehistoric	Small shell-gritted sherds.	2	2	0
121	12111	12109	Ditch	Iron Age-Roman	Two small abraded shell-gritted sherds.	2	9	0
123	12303	12302	Ditch	Prehistoric	Tiny vesicular sherds.	2	2	0
127	12706	12705	Ditch	Prehistoric?	A tiny shell-gritted sherd.	1	1	0
128	12803	12802	Ditch	Prehistoric?	A tiny shell-gritted sherd.	1	2	0
129	12903	12902	Ditch	Prehistoric?	A tiny shell-gritted sherd.	1	1	0
130	13005	13004	Ditch	Prehistoric	Small shell-gritted sherds.	2	11	2
136	13602	13602	Layer	Late Iron Age	A sherd from a jar or beaker with rouletted decoration.	1	10	0
136	13605	13603	Ditch	2C+	A small group including grey ware and a sherd from a folded beaker.	3	5	0
140	14010	14009	Ditch	Earlier Prehistoric	A single handmade shell-gritted sherd.	1	6	0

ESMP22 Dating Summary								
Trench	Context	F No	F Type	Spot date	Comments	Sherd	Weight (g)	Total RE %
141	14104	14103	Ditch	Late Iron Age to Early Roman	Sherds from a shell-gritted necked jar.	2	18	7
143	14304	14303	Plough furrow	?	Thin heavily abraded shell-gritted sherds probably of post-Roman date.	2	7	0
144	14405	14403	Pit	Prehistoric	Handmade sherds from a single vessel in a vesicular fabric.	2	15	0
146	14606	14605	Ditch	?	A single shell-gritted sherd, should be checked by a local post-Roman pottery specialist.	1	5	0
146	14614	14613	Ditch	Medieval+	Two green-glazed sherds.	2	9	0
151	15106	15105	Ditch	Iron Age?	A heavily abraded shell-gritted rim sherd.	1	19	2
158	15806	15805	Pit	Roman?	A small group including a light-fired sherd and a shell-gritted sherd which should be checked by a local post-Roman pottery specialist.	2	12	0
158	15808	15807	Ditch	Roman?	A single abraded oxidised sherd.	1	4	0
158	15812	15811	Ditch	Roman?	Shell-gritted sherds.	2	19	0
158	15814	15813	Ditch	M2-3	An abraded Nene Valley grey ware type sherd.	1	67	0
158	15816	15815	Ditch	Prehistoric	A single shell-gritted sherd.	1	55	0
159	15905	15904	Ditch	Prehistoric	A thick walled shell-gritted sherd with an inturned rim.	2	43	5
159	15906	15904	Ditch	Iron Age?	Thick-walled handmade sherds from sample 31, check date with Post-Roman pottery specialist.	3	67	0
159	15907	15904	Ditch	Late Iron Age to Early Roman	A small group including a sherd from a grog-gritted necked jar and shell-gritted sherds.	10	391	8
159	15910	15909	Ditch	3C+	A fresh small group including Nene Valley grey ware, and a colour-coated lipped bowl, a beaker, and a bowl with a grooved flange.	15	241	44
161	16103	16102	Ditch	Iron Age to Roman?	A small group of shell-gritted sherds, should be checked by a local post-Roman pottery specialist.	4	23	0
171	17103	17102	Ditch	Late Iron Age to Early Roman	A small group of shell-gritted sherds and the base from a platter in an oxidised sand-gritted fabric.	8	127	4
190	19004	19003	Ditch	Iron Age?	A single handmade shell-gritted sherd.	1	36	0
196	19605	19604	Ditch	Iron Age	Small handmade shell-gritted sherds.	2	19	0
200	20002	20002	Modern feature	Modern	A small group including a sherd of modern stoneware.	3	112	0
204	20400	20400	Layer	Iron Age?	Shell-gritted sherds from a single vessel, should be checked by a local post-Roman pottery specialist.	4	14	0
204	20403	20402	Pit	Iron Age?	Handmade shell-gritted thick-walled handmade sherds, and further similar material from sample 38, check date with Post-Roman pottery specialist.	13	166	2
204	20405	20404	Pit	Iron Age?	Handmade shell-gritted sherds and a further sherd from sample 36, check date with Post-Roman pottery specialist.	12	142	0

ESMP22 Dating Summary								
Trench	Context	F No	F Type	Spot date	Comments	Sherd	Weight (g)	Total RE %
204	20409	20407	Ditch	Iron Age?	Handmade shell-gritted sherds, should be checked by a local post-Roman pottery specialist.	3	19	0
209	20900	20900	Layer	3-4C	A fresh medium sized group including a sherd from a large colour-coated vessel, grey ware, and a large shell-gritted base.	24	799	0
209	20905	20903	Post hole	Late Iron Age to Early Roman	A small group including sherds from a shell-gritted necked jar.	7	111	4
209	20909	20908	Post hole	Iron Age?	A single abraded shell-gritted sherd.	1	11	0
209	20911	20910	Ditch	3-4C	A small group including grey ware, a Nene Valley type mortarium sherd, and shell-gritted sherds.	18	176	0
209	20913	20912	Post hole	Late Iron Age	Sherds from a handmade bowl with a low carination and cord-decoration. Further shell-gritted sherds came from sample 30.	5	161	16
209	20915	20914	Post hole	Iron Age to Roman	A single shell-gritted sherd.	1	16	0
209	20919	20918	Ditch	Iron Age	A single handmade shell-gritted rim.	1	16	2
209	20921	20920	Construction cut	Roman?	Two small shell-gritted sherds.	2	23	0
209	20923	20922	Ditch	Late Iron Age	A sherd from a carinated bowl very similar to that from context 20913, also sherds from shell-gritted jars with everted rims, one with a rilled shoulder. Further shell-gritted sherds came from sample 29.	58	1171	91
209	20927	20926	Ditch	Roman	Grey ware and shell-gritted sherds from a large jar.	5	258	0
209	20937	20936	Ditch	AD120-200	Samian and shell-gritted sherds.	2	9	0
209	20942	20940	Post hole	L1-2	A small group including sherds from a shell-gritted jar with an everted rim, and a grey ware jar.	16	209	8
209	20943	20940	Post hole	Roman?	A small group of shell-gritted sherds. Further sherds, including grey ware, came from sample 34.	4	43	0
209	20945	20944	Post hole	Roman	A single shell-gritted sherd.	1	28	0
209	20946	20944	Post hole	Late Iron Age to Early Roman	A small group of shell-gritted and oxidised sherds.	8	119	0
209	20949	20947	Post hole	M1-2	A large proportion of a jar with an everted rim and rilled shoulder. An oxidised sand-gritted sherd was also present.	31	749	89

Table 4: Summary of pottery by fabric type.

ESMP22 Full Fabric Summary							
Fabric code	Fabric group	Fabric details	Sherd	Sherd %	Weight (g)	Weight %	Total RE %
SAM	Samian	Undifferentiated	3	0.25%	5	0.03%	0
SAMCG	Samian	Central Gaulish	5	0.41%	48	0.31%	4

ESMP22 Full Fabric Summary							
Fabric code	Fabric group	Fabric details	Sherd	Sherd %	Weight (g)	Weight %	Total RE %
AM9A	Amphora	Dressel 20 - BAT AM1	1	0.08%	23	0.15%	0
MO	Mortaria	Unknown source	1	0.08%	8	0.05%	0
MO6	Mortaria	Nene valley fabric with slag trits	3	0.25%	65	0.42%	0
C11	Fine	Dark oxidised, dark reduced slip	1	0.08%	6	0.04%	0
C2	Fine	Colour coated with 'white' fabrics	98	8.11%	1388	8.94%	149
C3	Fine	Colour coated with a light oxidised core	19	1.57%	183	1.18%	34
C7	Fine	Dark oxidised fine sandy fabric, reduced slip	1	0.08%	1	0.01%	0
OW5	Oxidised	Medium sandy oxidised, may include unrecognised Medieval	8	0.66%	61	0.39%	2
WW	Oxidised	White wear unspecified	1	0.08%	1	0.01%	0
WW2	Oxidised	Fine white pipeclay fabric, includes Mancetter/Hartshill	1	0.08%	4	0.03%	0
WW4	Oxidised	Medium sandy- inc. Verulamium	1	0.08%	3	0.02%	0
BB1	Reduced	Black burnished 1, unspecified	5	0.41%	46	0.30%	7
GW	Reduced	Misc grey ware	5	0.41%	29	0.19%	15
GW2	Reduced	Fine grey ware fabric	4	0.33%	74	0.47%	0
GW3	Reduced	Fine sandy grey ware	24	1.99%	186	1.20%	15
GW4	Reduced	Light firing types as 'Nene Valley grey ware'	102	8.44%	1756	11.31%	116
GW5	Reduced	Medium sandy grey ware	41	3.39%	706	4.55%	30
GW6	Reduced	Moderately coarse wheel made grey ware	1	0.08%	3	0.02%	0
SW1	Sandy wares	Quartz mod-frequent IA tradition ware	1	0.08%	2	0.01%	2
SW2	Sandy wares	Transitional fine sandy wares	13	1.08%	110	0.71%	0
SW3	Sandy wares	Coarse sandy Belgic type LIA/Erom	2	0.17%	32	0.21%	9
CG	Shell gritted	Misc shell gritted	42	3.47%	340	2.19%	19
CG1	Shell	Shell gritted, coarse frequent-abundant	224	18.53%	2373	15.29%	68
CG1A	Shell	Shell gritted, low quartz, LIA-Erom	333	27.54%	4933	31.78%	247
CG1B	Shell	Shell gritted, low quartz, Late Rom	39	3.23%	696	4.48%	80
CG2	Shell	Shell gritted, sandier than CG1	31	2.56%	216	1.39%	6
CG2A	Shell	Shell gritted with sand, hand made	9	0.74%	160	1.03%	4
CG2B	Shell	As CG2A but wheel made (late?)	1	0.08%	5	0.03%	3
CG3A	Shell	Mod-freq shell, handmade, early	3	0.25%	37	0.24%	9
CG3B	Shell	Greetham type, wheel made	11	0.91%	87	0.56%	6
IV	Voids	Handmade indeterminate voids	7	0.58%	5	0.03%	0
IVCP	Voids & clay pellets	Handmade indeterminate voids with clay pellets	15	1.24%	66	0.43%	4
S1	Shell	Moderate-very common shell or platey voids	105	8.68%	955	6.15%	39
S2	Shell	As S1 with common-very common quartz sand	6	0.50%	33	0.21%	0
G1	Grog	Shelly & sandy fabric with sparse rounded grog	14	1.16%	260	1.68%	13
GT1	Grog	Coarse- 'Belgic' influence	2	0.17%	96	0.62%	4
GT2	Grog	Fine grog gritted 'Belgic' type	8	0.66%	211	1.36%	29
GT3A	Grog	Coarse- mid-late Roman pink	2	0.17%	66	0.43%	0
Q1	Quartz	Quartz sand common-abundant	2	0.17%	23	0.15%	0
MS	Medieval misc	Medieval unspecified	5	0.41%	17	0.11%	0
EA	Post-Roman	Unclassified post-med stoneware or earthenware	3	0.25%	30	0.19%	0

ESMP22 Full Fabric Summary							
Fabric code	Fabric group	Fabric details	Sherd	Sherd %	Weight (g)	Weight %	Total RE %
MSW	Post-Roman	Modern unclassified stoneware	3	0.25%	140	0.90%	0
FCLAY	Fired clay	Misc fired clay	3	0.25%	31	0.20%	0

Table 5: Summary of pottery by forms

ESMP22 Full Form Summary							
Form	Form Type	Form Description	Sherd	Sherd %	Weight (g)	Weight %	Total RE %
A	Amphora	Unclassified form	1	0.08%	23	0.15%	0
9	Beaker	Unclassified	10	0.83%	42	0.27%	0
9D	Beaker	Globular & bag-shaped	2	0.17%	32	0.21%	0
9E.2	Beaker	Beaded rim	1	0.08%	4	0.03%	9
9F.1	Beaker	Plain rim	1	0.08%	4	0.03%	11
9J	Beaker	Biconical, carinated	1	0.08%	18	0.12%	0
9J.1	Beaker	Biconical, carinated	2	0.17%	57	0.37%	0
5	Bowl	Unclassified	1	0.08%	20	0.13%	0
5C.2	Bowl	Vestigial neck	1	0.08%	118	0.76%	7
5D.2	Bowl	Low carination	7	0.58%	207	1.33%	27
5L	Bowl	Hemispherical or segmental with flange	1	0.08%	48	0.31%	0
5O	Bowl	Segmental/shallow as samian 18/31	1	0.08%	25	0.16%	7
B	Bowl	Unclassified form	1	0.08%	4	0.03%	4
6	Bowl/Dish	Unclassified	10	0.83%	200	1.29%	8
4A	Bowl/Jar	Everted/recurved	3	0.25%	59	0.38%	0
4B	Bowl/Jar	Necked/beaded, rolled, everted	17	1.41%	253	1.63%	32
4B.2	Bowl/Jar	Necked/beaded, rolled, everted	1	0.08%	20	0.13%	4
31	Dish	Samian form- see Webster 1996	3	0.25%	42	0.27%	0
6A	Dish	Plain rimmed	3	0.25%	35	0.23%	17
6A.1	Dish	Plain rimmed	1	0.08%	17	0.11%	3
6D	Dish	Stubby/flanged rim	6	0.50%	177	1.14%	51
6D.1	Dish	Stubby/flanged rim	1	0.08%	11	0.07%	4
6E.1	Dish	Groove-rimmed	2	0.17%	22	0.14%	7
6E.2	Dish	Groove-rimmed	6	0.50%	242	1.56%	46
1D.1	Flagons & Jugs	Flanged neck	1	0.08%	28	0.18%	0
3	Jar	Unclassified	152	12.57%	3778	24.34%	127
3A	Jar	Plain rim, neckless	2	0.17%	32	0.21%	9
3B	Jar	Bead rim, neckless	32	2.65%	838	5.40%	142
3B.1	Jar	Bead rim, neckless	2	0.17%	24	0.15%	8
3B.2	Jar	Bead rim, neckless	3	0.25%	147	0.95%	13
3D.2	Jar	Ledge rim	1	0.08%	19	0.12%	2
3F	Jar	Angular/everted rim	1	0.08%	14	0.09%	12
3G	Jar	Everted rim	3	0.25%	19	0.12%	16
3G.1	Jar	Everted rim	1	0.08%	23	0.15%	18
3L	Jar	Necked, squared off tip	7	0.58%	145	0.93%	51
3L.1	Jar	Necked, squared off tip	4	0.33%	55	0.35%	12
3L.2	Jar	Necked, squared off tip	2	0.17%	19	0.12%	12
3M	Jar	Necked, bead/rolled/everted tips	21	1.74%	298	1.92%	121
3M.2	Jar	Necked, bead/rolled/everted tips	13	1.08%	183	1.18%	44

ESMP22 Full Form Summary							
Form	Form Type	Form Description	Sherd	Sherd %	Weight (g)	Weight %	Total RE %
4	Jar/bowl	Unclassified	11	0.91%	164	1.06%	51
11F	Misc	Cheese press	1	0.08%	38	0.24%	7
M	Mortaria	Unclassified	4	0.33%	73	0.47%	0
7	Platter	Unclassified	2	0.17%	26	0.17%	0
7C.1	Platter	Flaring or flanged rim	2	0.17%	28	0.18%	7
-	Unknown	Form uncertain	861	71.22%	7889	50.83%	25

Table 6: Description of worked stone.

Context	Function	Notes	Size	Wt (g)	Lithology
1200	Whetstone	Thick whetstone with sub-triangular cross section and tapered in with and thickness from one end to the other. All the faces have been very heavily used so that they are dished and the arrises are mostly sharp with one that is rounded. Both ends have also been used. The smaller one looks like it broke in antiquity and was then reused	Measures 93mm in length x 58 x 69 at one end and 41 x 49 at the other	424	Fine-grained quartz sandstone
15900	Roofing?	Fragment of slate, broken on all edges. Some spalling at one end looks like two perforations but is probably natural		611	Grey blue slate
7204	Whetstone	Approximately oblong piece of stone that is probably building stone. There are some shallow U-shaped grooves across one face that might result from tool working	Measures >95 x 100 x 44mm	75	Calcareous beige sandstone

APPENDIX C: THE PALAEOENVIRONMENTAL EVIDENCE

Table 1: Identified animal species by fragment count (NISP) and weight and context.

Cut	Fill	BOS	O/C	SUS	EQ	Canis	Bird	LM	MM	Ind	S/A/F	BBSS	Total	Weight (g)
Late Neolithic-Early Bronze Age														
4407	4408									1			1	7
Prehistoric														
503	504									2		29	31	10
4220	4226	2	1					1	12				16	195
4220	4227									1			1	1
4411	4412	1											1	8
11406	11409	2	2							5			9	174
12705	12706			6									6	10
12802	12803									1			1	4
15815	15816	2			2								4	132
15904	15905	1											1	32
Subtotal		8	3	6	2			1	12	9		29	70	566
Iron Age														
111	112	6			3			19					28	606
	1200	3						2	12				17	111
11324	11325	2	3	1				2					8	72
11505	11507	4	2		1			1	18				26	175
11510	11511	2			1			11					14	191
11806	11808	1					9	7					17	45
11812	11814	1	3							6			10	17
11907	11908				1								1	29
11912	11913							10					10	45
19604	19605				1								1	131
20908	20909									2			2	6
20912	20913		4									12	16	51
20918	20919		2										2	18
20922	20923	6	3					7	6	17		49	88	348
Subtotal		25	17	1	7			9	59	36	25	61	240	1845
Late Iron Age/Early Roman														
102	103	1	1										2	67
1212	1213	1	4		1					2			8	69
1316	1317									2			2	7
	1500	1											1	18
11609	11611	1						2					3	57
11905	11906	5						12	5	15			37	139
12109	12111	1	1										2	15
15907	15907	6	2		1			7	8				24	748
16102	16103												2	4
17102	17103							2					2	34
20903	20905		1				1	1	2				5	20
20914	20915	1											1	54
20944	20946		1										1	7

Cut	Fill	BOS	O/C	SUS	EQ	Canis	Bird	LM	MM	Ind	S/A/F	BBSS	Total	Weight (g)
Subtotal		25	17		2		1	24	15	15			90	1239
Romano-British														
803	804	2							2				4	225
1502	1503	2						2	14				18	96
1504	1505	1											1	25
1506	1507	2						9					11	154
1506	1508	1								6			7	96
11203	11205	3	1										4	415
11303	11304	1	1					2					4	114
11311	11313	2		1	1				1				5	175
11318	11319									1			1	6
11330	11331		1					1					2	15
11406	11413	10	6	4				14	29	26			89	1196
11414	11415	1		1				2	9				13	50
11418	11419							8					8	53
11514	11516	1	1							1			3	17
11603	11604	21	2		1			26					50	1192
11612	11615	5	1			1		10					17	951
11612	11616	1			1			1					3	164
11705	11707	3								11			14	38
15805	15806	1											1	24
15807	15808	2	1					1					4	80
15811	15812	1											1	61
15813	15814	2											2	227
15909	15910	7	2		1			6					16	1120
	20900	1											1	87
20910	20911	5	1		2			13					21	449
20920	20921									2			2	4
20940	20942							1	3				4	24
20940	20943	1				2			2			21	26	1203
20947	20949		1							1			2	11
Subtotal		76	18	6	6	3		96	61	47		21	334	8272
Undated														
106	107	1											1	19
1304	1306									5			5	8
1402	1403							49					49	156
2313	2314				1								1	8
2503	2506									4			4	6
2510	2511	16											16	815
2510	2513									1			1	2
2703	2706		1							12			13	18
3004	3006	4	2		1			12					19	396
4007	4008	3	6	5				4	63				81	302
4203	4205										6		6	1
4203	4207	2											2	67
4220	4225		1										1	2
4235	4238										42		42	3

Cut	Fill	BOS	O/C	SUS	EQ	Canis	Bird	LM	MM	Ind	S/A/F	BBSS	Total	Weight (g)
4249	4250											21	21	2
4403	4404	2	4	2	2				41				51	193
7207	7212		1										1	14
10102	10105								2				2	8
11106	11107									4			4	11
11340	11326		1										1	6
11406	11410	1											1	161
11603	11606	1	1					1					3	57
11609	11610	2											2	82
11705	11706				1					3			4	20
11806	11809			1				1					2	23
11815	11816			1									1	4
11914	11915	1											1	4081
12103	12104	4											4	44
14012	14013	5											5	7
14703	14705									4			4	10
14703	14706									1			1	3
15809	15810	2											2	382
15904	15906		1						3				4	19
20404	20405	1	2										3	26
20916	20917	3	1		1					6			11	167
20924	20925	1							2				3	63
20931	20931									1			1	1
20938	20939									1			1	3
Subtotal		16	21	9	5			67	111	42	48	21	374	7190
Total		175	69	22	23	3	10	247	237	141	48	132	1109	
Weight		13219	645	242	967	1151	5	2086	500	261	4	35	19119	

BOS = Cattle; O/C = sheep/goat; SUS = pig; EQ = horse; Canid = dog; Bird = bird species; LM = large size mammal; MM = medium size mammal; Ind = indeterminate; S/A/F = small mammal/amphibian/fish; BBSS = burnt, unidentifiable fragments from bulk soil samples

Table 2: Summary marine shell quantification.

Area	Spot Date	Feature	Context	Oyster		Total	Total MNI
				No.	Min		
Trench 9	3C	Ditch 903	904	1	1	1	1
Trench 114	3-4C	Ditch 11406	11413	2	1	2	1

MNI = minimum number of individuals.

Table 3: Assessment of the palaeoenvironmental remains.

Feature	Context	Sample	Processed vol (L)	Unprocessed vol (L)	Flot size (ml)	Roots %	Grain	Chaff	Cereal Notes	Charred Other	Charred Other Notes	Charcoal > 4/2mm	Other
Trench 1													
Ring Gully 109	110	20	19	0	32	95	-	-	-	-	-	*/*	-
Trench 5													
Pit 503	504	21	20	0	21	95	-	-	-	*	<i>Vicia; Odontites vernus; Polygonum aviculare</i>	**/**	-
Trench 42													
Ring Ditch 4220	4226	2	20	20	77	90	-	-	-	-	-	****/****	moll-t (***)
Pit 4249	4250	3	9	0	25	20	-	-	-	-	-	**/**	-
Trench 63													
Pit 6303	6304	22	20	0	30	95	*	-	Barley	-	-	**/**	moll-t (****); moll-a (*)
Trench 114													
Ditch 11406	11413	11	20	20	15	80	***	-	Indet grain; hulled wheat grain; wheat grain	*	<i>Brassica; Avena/Bromus; Rumex crispus</i>	**/**	moll-t (****); moll-a (*)
Trench 115													
Ditch 11505	11507	9	2	18	750	<1	-	-	-	-	-	-	moll-t (****); moll-a (*)
Trench 116													
Ditch 11612	11615	16	20	0	10	70	*	*	Indet grain; hulled wheat glume	*	<i>Rumex acetosella</i>	**/*	moll-t (**); moll-a (**)
Trench 118													
Ditch 11803	11808	8	20	0	25	85	-	-	-	**	<i>Prunus spinosa; Avena/Bromus; Sambucus; Galium; Trifolium/Medicago</i>	**/**	moll-t (*)
Trench 159													
Ditch 15904	15906	31	8	0	50	80	*	-	Hulled wheat grain	*	Bud; <i>Brassica nigra; Poa/Phleum</i>	****/****	moll-t (**)
Ditch 15909	15910	37	10	0	17	98	*	-	Wheat grain	*	<i>Sinapsis arvensis</i>	*/*	moll-t (*)
Trench 190													
Ditch 19003	19004	41	2	0	260	<1	-	-	-	-	-	*/*	-
			13	0	7	98	*	-	Indet grain	*	<i>Corylus avellana; Rumex acetosella</i>	**/**	-
Ditch 19007	19008	43	2	18	230	<1	-	-	-	-	-	*/*	-
Trench 196													
Ditch 19604	19605	39	2	18	300	<1	-	-	-	-	-	-/*	-

Trench 197													
Ring Ditch 19703	19704	40	2	18	175	<1	-	-	-	-	-	*/**	-
Trench 204													
Pit 20404	20405	36	14	0	20	98	*	-	Indet grain	-	-	*/**	moll-t (*)
Pit 20402	20403	38	13	0	10	98	-	-	-	*	<i>Rubus</i>	*/**	moll-t (*)
Trench 209													
Ditch 20922	20923	29	18	0	60	85	*	*	Indet grain; hulled wheat grain; hulled wheat glume base	*	<i>Galium; Odontites vernus</i>	***/*	brnt bn (*); moll-t (**); moll-a (*)
Posthole 20912	20913	30	19	0	47	95	*	-	Indet grain; wheat grain	-	-	***/*	moll-t (**)
Posthole 20940	20943	34	8	0	13	80	*	-	Indet grain	*	<i>Prunus</i>	***/*	moll-t (*)

Key: * = 1–4 items; ** = 4–20 items; *** = 21–49 items; **** = 50–99 items; ***** = >100 items

moll-t = terrestrial mollusc, moll-a = aquatic/freshwater mollusc, brnt bn = burnt bone

APPENDIX D: OASIS REPORT FORM

PROJECT DETAILS	
Project name	Mallard Pass Solar Farm DCO, Essendine, Rutland & Lincolnshire
Short description	<p>Between September and December 2022, Cotswold Archaeology carried out a programme of trial trenching of land within the surrounding environs of Essendine, Rutland, extending across the border into the South Kesteven administrative area of Lincolnshire. A total of 209 trenches were excavated, largely targeting anomalies identified by a preceding geophysical survey.</p> <p>This draft report has been submitted to PINS for onward dissemination to the Local Authority archaeological advisors and at the date of issue has not been reviewed or received comments from the advisors.</p> <p>An initial interim report on the results of the trial trenching was submitted with the DCO application. The interim noted that a full report including a detailed analysis of the completed fieldwork, which this document represents, would be provided in due course. This full report is based on the same fieldwork reported on in the interim report, providing additional baseline information which supplements the preliminary results previously submitted. The conclusions of the Environmental Statement regarding the baseline characteristics of the investigated areas are not changed as a result of the updated information provided.</p> <p>The main focal areas of archaeological activity identified by the trenching were accurately predicted by the geophysical survey, particularly in field parcels M6, M10, and PF7. Archaeologically relatively quiet or blank areas indicated by the geophysical survey also were confirmed as such by the results of the trial trenching. However, not all areas predicted by the geophysical survey to contain archaeological remains did so; for example, trenches 33 – 39, in field parcel M10, contained only a single archaeological feature despite having been targeted at a cluster of anomalies morphologically suggestive of a trackway, enclosures and a possible ring ditch. Similarly, trenches 136, 137 and 138 in land parcel PF8 and trenches 183 – 188 in land parcel N8 also contained no archaeological remains despite the presence of morphologically suggestive geophysical anomalies.</p> <p>In respect of this, across the majority of the trenching areas high levels of modern plough truncation, plough scaring and evidence for wheel rutting were observed. In field parcel M6 in particular, quantities of artefactual material were noted in the ploughsoil in the vicinity of the trenches, suggesting plough erosion of the underlying remains was actively occurring. Particularly heavy plough scarring was also noted across land parcels P1 and M11. Consequently, it is conjectured that some of the anomalies identified by the geophysical survey, where not clearly related to geological variations etc, may be the result of ploughed-out archaeological features surviving as soil bands in the agricultural plough soil.</p> <p>The remains encountered in the trenches were shown to be predominantly Iron Age and Roman in date, with little evidence for activity pre- or post-dating these periods being identified. The principal exception to this was a complex of curvilinear ditches and associated features in field parcel M10 (trenches 40, 42 and 45), where a double ring ditch identified by the geophysical survey and targeted by trench 42, appears to be Late Neolithic/ Early Bronze Age in date. Thought on morphological grounds to be a possible burial mound, the absence of any burial pit within the central area of the inner ditch, coupled with evidence for the recutting of both the inner and outer ditch and the presence of pottery and animal bone in the ditches and nearby (seemingly associated) features imply a non-funerary function for the enclosure.</p>

	<p>In field parcel M6, an area of Late Iron Age and Early Roman activity was encountered, including a possible stone surface and large quantities of artefacts. The animal bone recovered from this area was dominated by the remains of cattle, almost to the exclusion of other species, consisting exclusively of meat-poor skeletal elements, specifically fragments of the mandible and lower limbs. The bone was well preserved and displayed frequent cut marks; such damage is highly suggestive of the waste from primary butchery where bones that hold little or no meat are removed from the carcass.</p> <p>A dense area of geophysical anomalies investigated in field parcel PF7 translated into a large number of intercutting ditches, pits, and occupation horizons. The density of features in this area, and the scale and variety of the finds recovered from the features suggest the presence of a small settlement, possibly a farmstead. Pottery evidence indicates activity at this location from the Late Iron Age onwards, spanning the Iron Age – Roman transition and on into the 3rd – 4th century, although it is not clear if this was truly continuous. In contrast to field parcel M6 the cattle bone consisted of elements from throughout the skeleton, with bones both rich and poor in meat yield recovered in relatively equal amounts. Evidence of butchery was common, with bones displaying heavy chop marks highly suggestive of the waste from secondary butchery where a carcass is separated up into manageable portions of meat.</p> <p>Further to the south and south-east from land parcel PF7, and in particular across field parcels N7/N8 and N11, a lower level of activity was seen, mostly in the form of possible enclosure and field boundary ditches. However, remains of a possible building of Roman date were encountered in field parcel N7. As with the remains in land parcel PF7, pottery of Late Iron Age, Late Iron Age – Early Roman transition and 3rd – 4th century date was recovered from this area, with pottery of Late Iron Age – Early transitional style/ date recovered from structural postholes suggesting that the building may have been constructed in the 1st century AD. Animal bone recovered from these features was again almost entirely cattle and displayed signs of primary butchery, suggesting the Iron Age – Roman activity in parcels M6 and N8 may represent satellite centres of activity to the main settlement focus in PF7 and were primarily involved in stock raising/ primary butchery, the butchered meat then being consumed at the PF7 settlement.</p> <p>Although no clear evidence was encountered for the continued occupation of the PF7 settlement and surrounding associated field systems beyond the late Roman period, a small number of pot sherds of possible post-Roman date may indicate a low level of activity continuing into the Saxon period. The area subsequently appears to have formed part of the agricultural landscape surrounding the small medieval settlements at Essendine and Ryhall and continued as agricultural land through the post-medieval and modern periods.</p>
Project dates	20 September – 20 December 2022
Project type	Field evaluation
Previous work	Geophysical survey (Magnitude 2022)
Future work	Unknown
PROJECT LOCATION	
Site location	Land around Essendine, Rutland & Lincolnshire
Study area (m ² /ha)	350ha
Site co-ordinates	NGR 505490 312483
PROJECT CREATORS	
Name of organisation	Cotswold Archaeology
Project brief originator	
Project design (WSI) originator	Cotswold Archaeology
Project Manager	Adrian Scruby
Project Supervisor	Anna Wolf

MONUMENT TYPE	Ditches, pits, postholes, furrows (all multi-period)	
SIGNIFICANT FINDS	Animal bone, oyster shell, palaeoenvironmental remains, pottery, ceramic building material, fired clay, metalwork, industrial waste	
PROJECT ARCHIVES	Intended final location of archive (museum/Accession no.)	Content (e.g. pottery, animal bone etc)
Physical	Rutland County Museum (OAKRM: 2022.49) & The Collection Museum (Lincolnshire County Council; LCNCC: 2022.131)	Animal bone, oyster shell, palaeoenvironmental remains, pottery, ceramic building material, fired clay, metalwork, industrial waste
Paper	Rutland County Museum (OAKRM: 2022.49) & The Collection Museum (Lincolnshire County Council; LCNCC: 2022.131)	Context sheets, section drawings, photo registers
Digital	Archaeology Data Service (ADS)	Digital site records, digital photographs, site plans
BIBLIOGRAPHY		
Cotswold Archaeology 2009 <i>Mallard Pass Solar Farm DCO, Essendine, Rutland & Lincolnshire: Archaeological Evaluation</i> CA typescript report MK0789_2		

Andover Office

Stanley House
Walworth Road
Andover
Hampshire
SP10 5LH

t: 01264 347630

Cirencester Office

Building 11
Cotswold Business Park
Cirencester
Gloucestershire
GL7 6BQ

t: 01285 771022

Milton Keynes Office

Unit 8 - The IO Centre
Fingle Drive, Stonebridge
Milton Keynes
Buckinghamshire
MK13 0AT

t: 01908 564660

Suffolk Office

Unit 5, Plot 11, Maitland Road
Lion Barn Industrial Estate
Needham Market
Suffolk
IP6 8NZ

t: 01449 900120

e: enquiries@cotswoldarchaeology.co.uk



Mallard Pass Solar Farm Essendine Rutland & Lincolnshire

Supplementary Archaeological Evaluation

Volume 2: Report illustrations



for:
LDA Design Consulting Ltd

CA Project: MK0789
CA Site Code: ESMP22
CA Report: MK0789_2

Rutland Accession Number; OAKRM: 2022.49
Lincolnshire Accession Number; LCNCC: 2022.131

April 2023

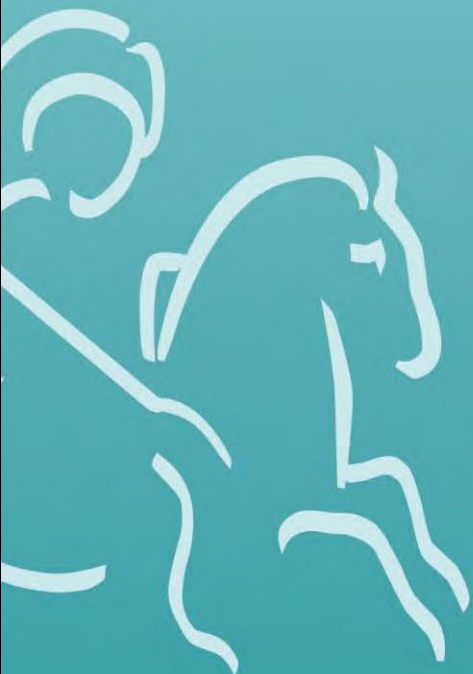

Mallard Pass Solar Farm Essendine Rutland & Lincolnshire

Supplementary Archaeological Evaluation

Volume 2: Report illustrations

CA Project: MK0789
CA Site Code: ESMP22
CA Report: MK0789_2

Rutland Accession Number; OAKRM: 2022.49
Lincolnshire Accession Number; LCNCC: 2022.131

Document Control Grid						
Revision	Date	Author	Checked by	Status	Reasons for revision	Approved by
1	22.03.2023	Anna Wolf	Adrian Scruby	Draft	–	Adrian Scruby
2	28.04.2023	Anna Wolf	Adrian Scruby	Draft	Client review	Adrian Scruby

This report is confidential to the client. Cotswold Archaeology accepts no responsibility or liability to any third party to whom this report, or any part of it, is made known. Any such party relies upon this report entirely at their own risk. No part of this report may be reproduced by any means without permission.

Cirencester Building 11 Cotswold Business Park Cirencester Gloucestershire GL7 6BQ t. 01285 771 022	Milton Keynes Unit 8, The IO Centre Fingle Drive, Stonebridge Milton Keynes Buckinghamshire MK13 0AT t. 01908 564 660	Andover Stanley House Walworth Road Andover Hampshire SP10 5LH t. 01264 347 630	Suffolk Unit 5, Plot 11 Maitland Road Lion Barn Industrial Estate Needham Market Suffolk IP6 8NZ t. 01449 900 120
--	--	--	--

e. enquiries@cotswoldarchaeology.co.uk

LIST OF ILLUSTRATIONS

Fig. 1 Site location plan (1:40,000)

Fig. 2 Trench layout plan showing areas and field numbers (1:25,000)

Fig. 3 Trench layout plan (Area M11 north) showing geophysical survey results and archaeological features (1:2,000)

Fig. 4 Trench layout plan (Area M11 south) showing geophysical survey results and archaeological features (1:2,000)

Fig. 5 Trench layout plan (Area M6) showing geophysical survey results and archaeological features (1:2,000)

Fig. 6 Trench layout plan (Area M10) showing geophysical survey results and archaeological features (1:2,000)

Fig. 7 Trench layout plan (Area M7) showing geophysical survey results and archaeological features (1:2,000)

Fig. 8 Trench layout plan (Area M10) showing geophysical survey results and archaeological features (1:2,000)

Fig. 9 Trench layout plan (Area W3) showing geophysical survey results and archaeological features (1:2,000)

Fig. 10 Trench layout plan (W2) showing geophysical survey results and archaeological features (1:2,000)

Fig. 11 Trench layout plan (P1 and W1) showing geophysical survey results and archaeological features (1:2,000)

Fig. 12 Trench layout plan (Area P2) showing geophysical survey results and archaeological features (1:2,000)

Fig. 13 Trench layout plan (Area P3 and P6) showing geophysical survey results and archaeological features (1:2,000)

Fig. 14 Trench layout plan (Area P3 and P6) showing geophysical survey results and archaeological features (1:2,000)

Fig. 15 Trench layout plan (Areas PF1–2) showing geophysical survey results and archaeological features (1:2,000)

Fig. 16 Trench layout plan (Areas PF4–6) showing geophysical survey results and archaeological features (1:2,000)

Fig. 17 Trench layout plan (Areas PF7–8) showing geophysical survey results and archaeological features (1:2,000)

Fig. 18 Trench layout plan (Areas N8 (north), N11–12) showing geophysical survey results and archaeological features (1:2,000)

Fig. 19 Trench layout plan (Areas N7–7) showing geophysical survey results and archaeological features (1:2,000)

Fig. 20 Trench layout plan (Area N8 (south)) showing geophysical survey results and archaeological features (1:2,000)

Fig. 21 Trench layout plan (Area N3) showing geophysical survey results and archaeological features (1:2,000)

Fig. 22 Selection of blank trenches in Rutland: photographs

Fig. 23 Selection of blank trenches in Rutland: photographs

Fig. 24 Selection of blank trenches in Lincolnshire: photographs

Fig. 25 Selection of blank trenches in Lincolnshire: photographs

Fig. 26 Area M11 (Lincolnshire), Trench 1: plan, sections and photographs (1:200, 1:20)

Fig. 27 Area M11 (Lincolnshire), Trench 1: section and photograph (1:20)

Fig. 28 Area M11 (Lincolnshire), Trench 2: plan, section and photographs (1:200, 1:20)

Fig. 29 Area M11 (Lincolnshire), Trench 8: plan, section and photographs (1:200, 1:20)

Fig. 30 Area M11 (Lincolnshire), Trench 9: plan, section and photographs (1:200, 1:20)

Fig. 31 Area M6 (Rutland), Trench 12: plan, section and photographs (1:200, 1:20)

Fig. 32 Area M6 (Rutland), Trench 13a: plan, section and photographs (1:200, 1:20)

Fig. 33 Area M6 (Rutland), Trench 13: photograph

Fig. 34 Area M6 (Rutland), Trench 15: plan and photograph (1:200)

Fig. 35 Area M6 (Rutland), Trench 15: sections and photographs (1:20)

Fig. 36 Area M7 (Rutland), Trench 25: plan, section and photographs (1:200, 1:20)

-
- Fig. 37 Area M7 (Rutland), Trench 27: plan, section and photographs (1:200, 1:20)
- Fig. 38 Area M10 (Rutland), Trench 40: plan, section and photographs (1:200, 1:20)
- Fig. 39 Area M10 (Rutland), Trench 42: plan, section and photographs (1:200, 1:20)
- Fig. 40 Area M10 (Rutland), Trench 42: section and photograph (1:20)
- Fig. 41 Area M10 (Rutland), Trench 44: plan, sections and photographs (1:200, 1:20)
- Fig. 42 Area P1 (Rutland), Trench 67: plan, section and photographs (1:200, 1:20)
- Fig. 43 Area P2 (Rutland), Trench 71: plan, section and photographs (1:200, 1:20)
- Fig. 44 Area P2 (Rutland), Trench 72: plan, sections and photographs (1:200, 1:20)
- Fig. 45 Area P11 (Rutland), Trench 86: plan, section and photographs (1:200, 1:20)
- Fig. 46 Area P12 (Rutland), Trench 95: plan, section and photographs (1:200, 1:20)
- Fig. 47 Area PF1 (Rutland), Trench 101: plan, section and photographs (1:200, 1:20)
- Fig. 48 Area PF1 (Rutland), Trench 103: plan, section and photographs (1:200, 1:20)
- Fig. 49 Area PF1 (Rutland), Trench 104: plan, section and photographs (1:200, 1:20)
- Fig. 50 Area PF1 (Rutland), Trench 104: section and photograph (1:20)
- Fig. 51 Area PF4 (Rutland), Trench 111: plan, section and photographs (1:200, 1:20)
- Fig. 52 Area PF4 (Rutland), Trench 111: section and photograph (1:20)
- Fig. 53 Area PF5 (Rutland), Trench 112: plan, section and photographs (1:200, 1:20)
- Fig. 54 Area PF5 (Rutland), Trench 113: plan, section and photographs (1:200, 1:20)
- Fig. 55 Area PF5 (Rutland), Trench 113: section and photograph (1:20)
- Fig. 56 Area PF5 (Rutland), Trench 114: plan, section and photographs (1:200, 1:20)
- Fig. 57 Area PF5 (Rutland), Trench 114: section and photograph (1:20)
- Fig. 58 Area PF5 (Rutland), Trench 115: plan, section and photographs (1:200, 1:20)
- Fig. 59 Area PF5 (Rutland), Trench 115: section and photograph (1:20)
- Fig. 60 Area PF5 (Rutland), Trench 116: plan and photograph (1:200)
- Fig. 61 Area PF5 (Rutland), Trench 116: section and photograph (1:20)
- Fig. 62 Area PF7 (Rutland), Trench 117: plan, section and photographs (1:200, 1:20)

-
- Fig. 63 Area PF7 (Rutland), Trench 117: section and photograph (1:20)
- Fig. 64 Area PF7 (Rutland), Trench 119: plan, section and photographs (1:200, 1:20)
- Fig. 65 Area PF7 (Rutland), Trench 119: sections and photographs (1:20)
- Fig. 66 Area PF7 (Rutland), Trench 121: plan, section and photographs (1:200, 1:20)
- Fig. 67 Area PF7 (Rutland), Trench 121: section and photograph (1:20)
- Fig. 68 Area PF8 (Rutland), Trench 129: plan, section and photographs (1:200, 1:20)
- Fig. 69 Area PF8 (Rutland), Trench 130: plan, section and photographs (1:200, 1:20)
- Fig. 70 Area PF8 (Lincolnshire), Trench 136: plan, section and photographs (1:200, 1:20)
- Fig. 71 Area N11 (Lincolnshire), Trench 142: plan, section and photographs (1:200, 1:20)
- Fig. 72 Area N11 (Lincolnshire), Trench 144: plan, section and photographs (1:200, 1:20)
- Fig. 73 Area N11 (Lincolnshire), Trench 145: plan, section and photographs (1:200, 1:20)
- Fig. 74 Area N11 (Lincolnshire), Trench 145: section and photograph (1:20)
- Fig. 75 Area N11 (Lincolnshire), Trench 151: plan, section and photographs (1:200, 1:20)
- Fig. 76 Area N7 (Lincolnshire), Trench 159: plan, section and photographs (1:200, 1:20)
- Fig. 77 Area N7 (Lincolnshire), Trench 171: plan, section and photographs (1:200, 1:20)
- Fig. 78 Area N6 (Lincolnshire), Trench 177: plan, section and photographs (1:200, 1:20)
- Fig. 79 Area N8 (Lincolnshire), Trench 182: plan, section and photographs (1:200, 1:20)
- Fig. 80 Area N3 (Lincolnshire), Trench 190: plan, sections and photographs (1:200, 1:20)
- Fig. 81 Area N3 (Lincolnshire), Trench 197: plan, section and photographs (1:200, 1:20)
- Fig. 82 Area N3 (Lincolnshire), Trench 204: plan, section and photographs (1:200, 1:20)
- Fig. 83 Area N7 (Lincolnshire), Trench 209: plan, section and photographs (1:200, 1:20)
- Fig. 84 Area N3 (Lincolnshire), Trench 209: sections and photographs (1:20)

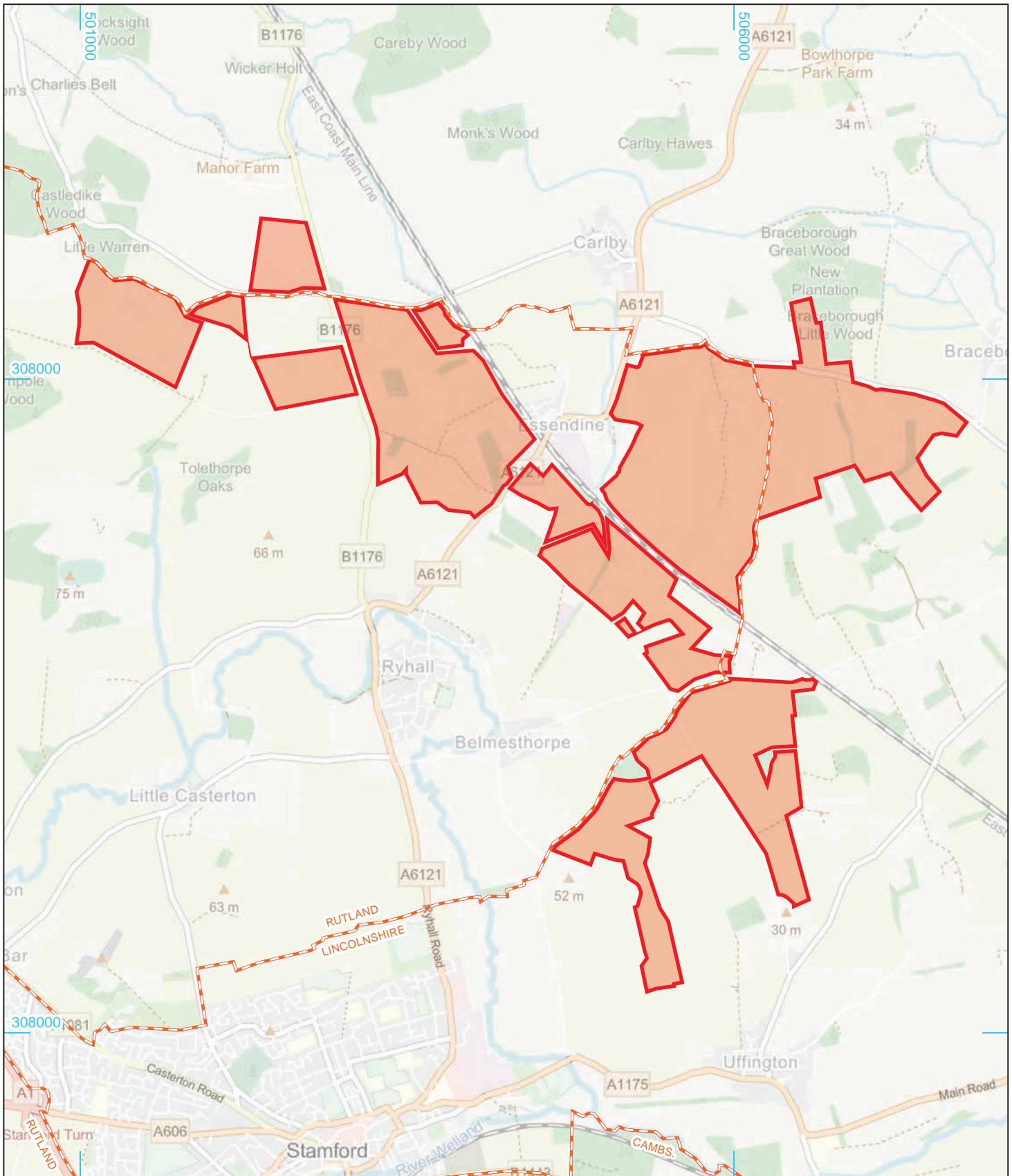

- Site boundary
- County boundary



Andover 01264 347630
 Cirencester 01285 771022
 Milton Keynes 01908 564660
 Suffolk 01449 900120
www.cotswoldarchaeology.co.uk
enquiries@cotswoldarchaeology.co.uk

PROJECT TITLE
 Mallard Pass Solar Farm DCO,
 Essendine, Rutland & Lincolnshire

FIGURE TITLE
 Site location plan

DRAWN BY RW	PROJECT NO. MK0789	FIGURE NO.
CHECKED BY DJB	DATE 07/02/2023	
APPROVED BY AW	SCALE@A4 1:40,000	1

© OpenStreetMap (and) contributors, CC-BY-SA, Esri Community Maps Contributors, Esri UK, Esri, HERE, Garmin, Foursquare, GeoTechnologies, Inc, METINASA, USGS

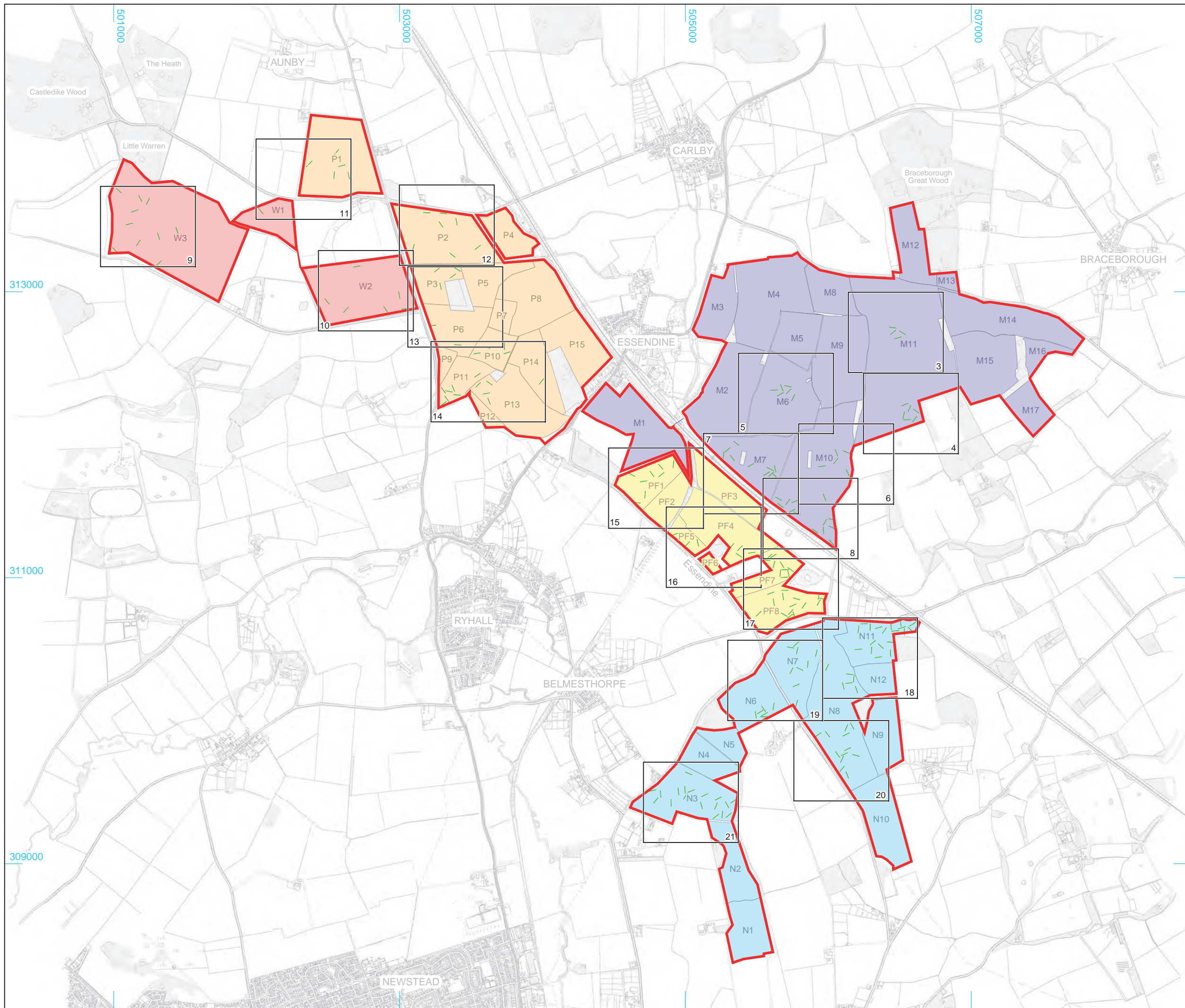

- Site boundary
- Evaluation trench
- Area M
- Area N
- Area P
- Area PF
- Area W
- Figure reference



© Crown copyright and database rights 2022 Ordnance Survey 0100031673

Cotswold Archaeology
 Andover 01264 347630
 Cirencester 01285 771022
 Milton Keynes 01908 564660
 Suffolk 01449 900120
www.cotswoldarchaeology.co.uk
enquiries@cotswoldarchaeology.co.uk

PROJECT TITLE
 Mallard Pass Solar Farm DCO,
 Essendine, Rutland & Lincolnshire

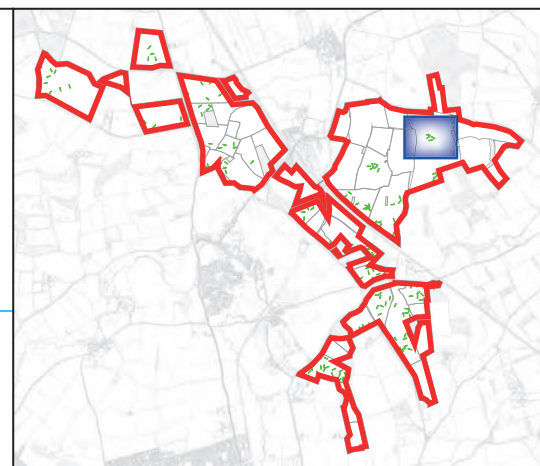
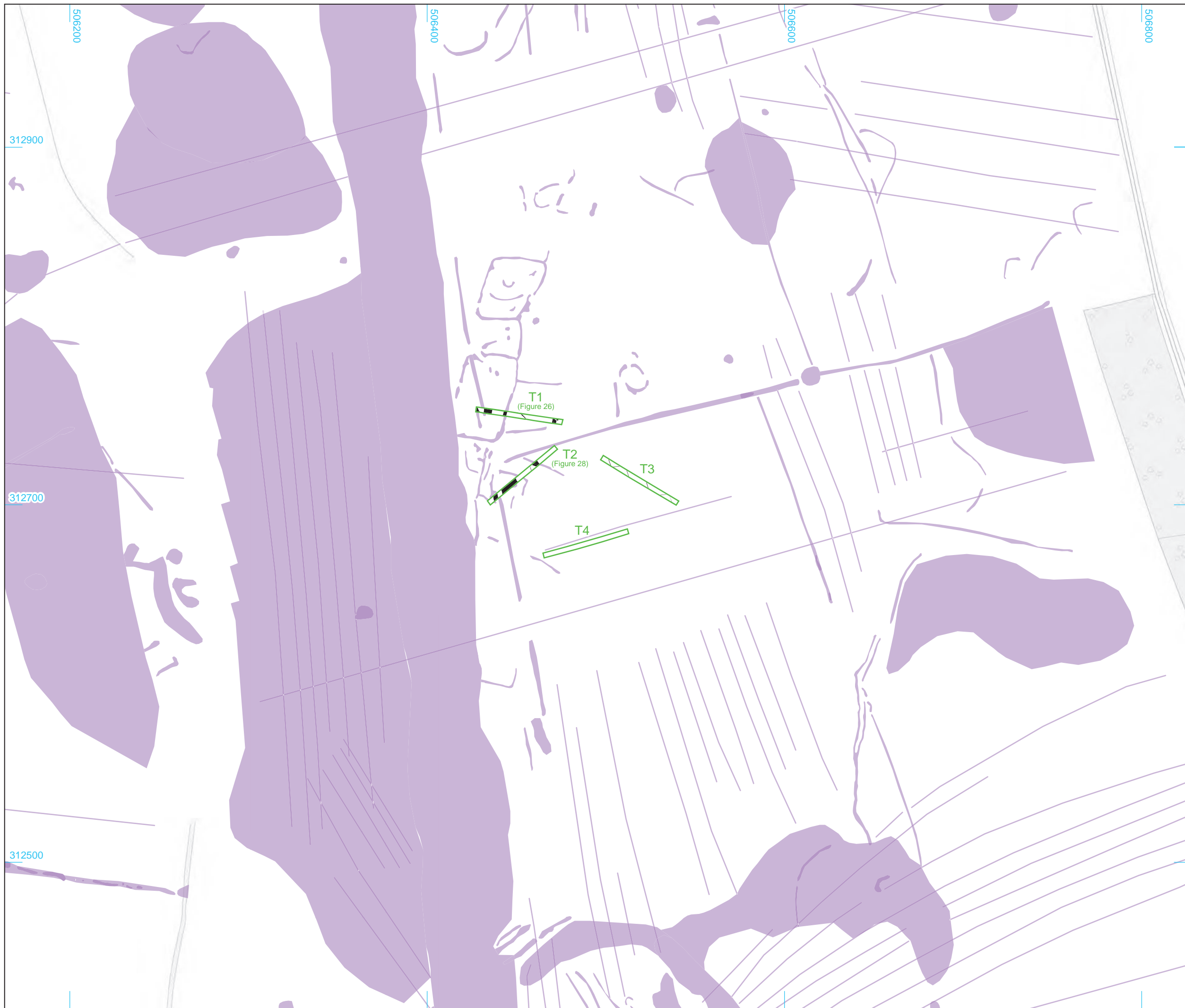

FIGURE TITLE
 Trench layout plan showing areas and
 field numbers

DRAWN BY CHECKED BY APPROVED BY	RW DJB AW	PROJECT NO. DATE SCALE@A3	MK0789 07/02/2023 1:25,000	FIGURE NO. 2
---------------------------------------	-----------------	---------------------------------	----------------------------------	------------------------



-  Site boundary
-  Evaluation trench
-  Identified feature

*Geophysical survey results
(Magnitude Surveys 2022)*

-  Area
-  Trend



© Crown copyright and database rights 2022 Ordnance Survey 0100031673

 Cotswold Archaeology

Andover 01264 347630
 Cirencester 01285 771022
 Milton Keynes 01908 564660
 Suffolk 01449 900120
 www.cotswoldarchaeology.co.uk
 enquiries@cotswoldarchaeology.co.uk

PROJECT TITLE
 Mallard Pass Solar Farm DCO,
 Essendine, Rutland & Lincolnshire

FIGURE TITLE
 Trench layout plan (Area M11 north)
 showing geophysical survey results
 and archaeological features

<small>DRAWN BY</small> RW	<small>PROJECT NO.</small> MK0789	<small>FIGURE NO.</small>
<small>CHECKED BY</small> DJB	<small>DATE</small> 07/02/2023	3
<small>APPROVED BY</small> AW	<small>SCALE@A3</small> 1:2000	

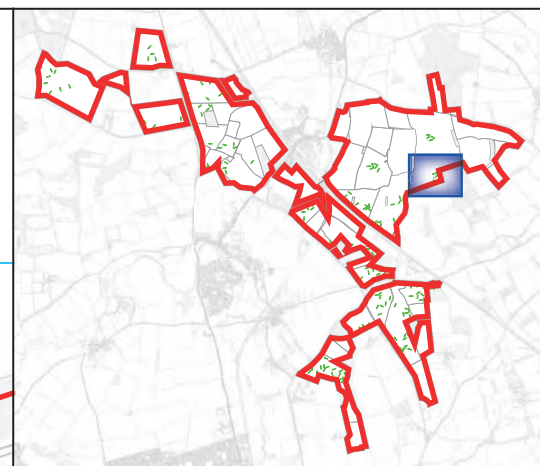

- N
- Site boundary
 - Evaluation trench
 - Identified feature
- Geophysical survey results
(Magnitude Surveys 2022)*
- Area
 - Trend



© Crown copyright and database rights 2022 Ordnance Survey 0100031673

Andover 01264 347630
Cirencester 01285 771022
Milton Keynes 01908 564660
Suffolk 01449 900120
www.cotswoldarchaeology.co.uk
enquiries@cotswoldarchaeology.co.uk

PROJECT TITLE
Mallard Pass Solar Farm DCO,
Essendine, Rutland & Lincolnshire

FIGURE TITLE
**Trench layout plan (Area M11 south)
showing geophysical survey results
and archaeological features**

<small>DRAWN BY</small> RW	<small>PROJECT NO.</small> MK0789	<small>FIGURE NO.</small>
<small>CHECKED BY</small> DJB	<small>DATE</small> 07/02/2023	4
<small>APPROVED BY</small> AW	<small>SCALE@A3</small> 1:2000	

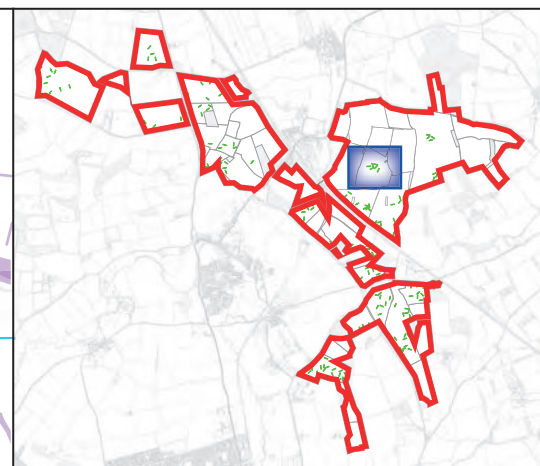
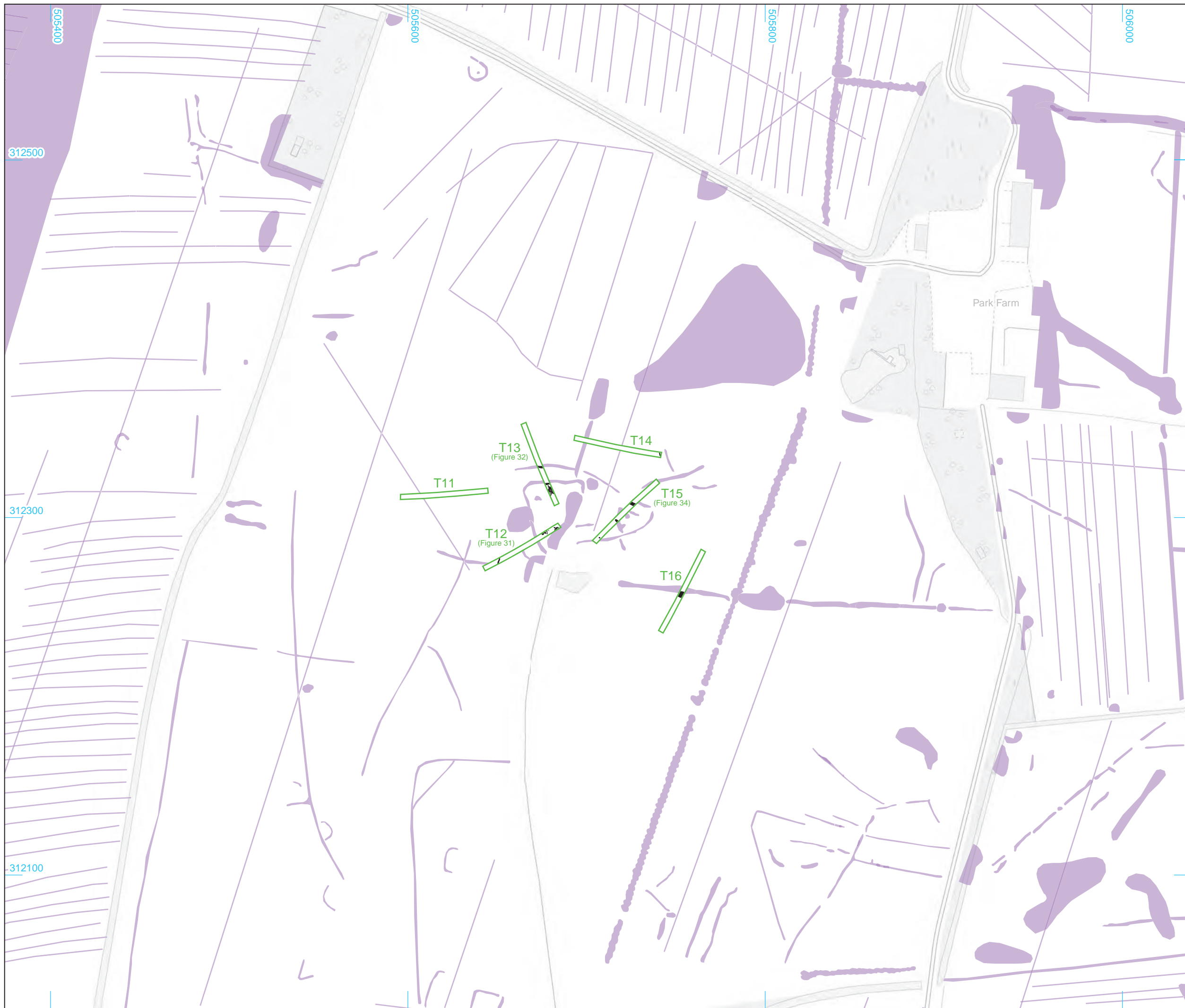

- Site boundary
- Evaluation trench
- Identified feature

Geophysical survey results
(Magnitude Surveys 2022)

- Area
- Trend



© Crown copyright and database rights 2022 Ordnance Survey 0100031673

Cotswold Archaeology
 Andover 01264 347630
 Cirencester 01285 771022
 Milton Keynes 01908 564660
 Suffolk 01449 900120
www.cotswoldarchaeology.co.uk
enquiries@cotswoldarchaeology.co.uk

PROJECT TITLE
Mallard Pass Solar Farm DCO,
Essendine, Rutland & Lincolnshire

FIGURE TITLE
**Trench layout plan (Area M6) showing
geophysical survey results and
archaeological features**

DRAWN BY	RW	PROJECT NO.	MK0789	FIGURE NO.
CHECKED BY	DJB	DATE	07/02/2023	5
APPROVED BY	AW	SCALE@A3	1:2000	

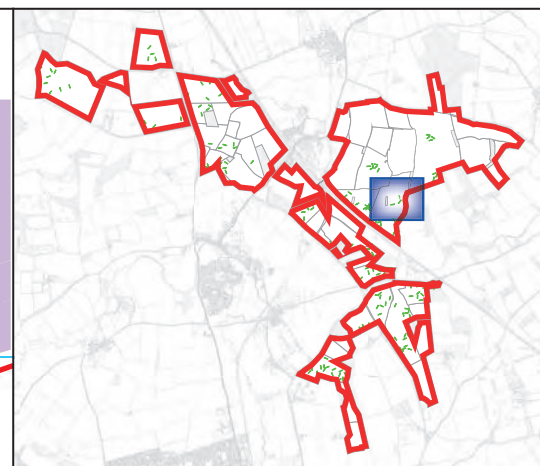

- Site boundary
- Evaluation trench
- Identified feature

Geophysical survey results
(Magnitude Surveys 2022)

- Area
- Trend



© Crown copyright and database rights 2022 Ordnance Survey 0100031673

Andover 01264 347630
Cirencester 01285 771022
Milton Keynes 01908 564660
Suffolk 01449 900120
www.cotswoldarchaeology.co.uk
enquiries@cotswoldarchaeology.co.uk

PROJECT TITLE
Mallard Pass Solar Farm DCO,
Essendine, Rutland & Lincolnshire

FIGURE TITLE
**Trench layout plan (Area M10) showing
geophysical survey results and
archaeological features**

<small>DRAWN BY</small> RW	<small>PROJECT NO.</small> MK0789	<small>FIGURE NO.</small>
<small>CHECKED BY</small> DJB	<small>DATE</small> 07/02/2023	6
<small>APPROVED BY</small> AW	<small>SCALE@A3</small> 1:2000	

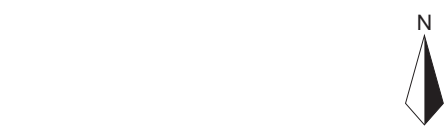
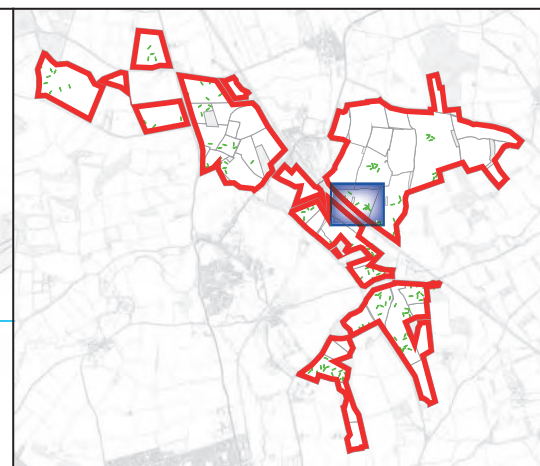

- Site boundary
- Evaluation trench
- Identified feature

*Geophysical survey results
(Magnitude Surveys 2022)*

- Area
- Trend



© Crown copyright and database rights 2022 Ordnance Survey 0100031673

Andover 01264 347630
Cirencester 01285 771022
Milton Keynes 01908 564660
Suffolk 01449 900120
www.cotswoldarchaeology.co.uk
enquiries@cotswoldarchaeology.co.uk

PROJECT TITLE
Mallard Pass Solar Farm DCO,
Essendine, Rutland & Lincolnshire

FIGURE TITLE
**Trench layout plan (Area M7) showing
geophysical survey results and
archaeological features**

<small>DRAWN BY</small> RW	<small>PROJECT NO.</small> MK0789	<small>FIGURE NO.</small>
<small>CHECKED BY</small> DJB	<small>DATE</small> 07/02/2023	7
<small>APPROVED BY</small> AW	<small>SCALE@A3</small> 1:2000	

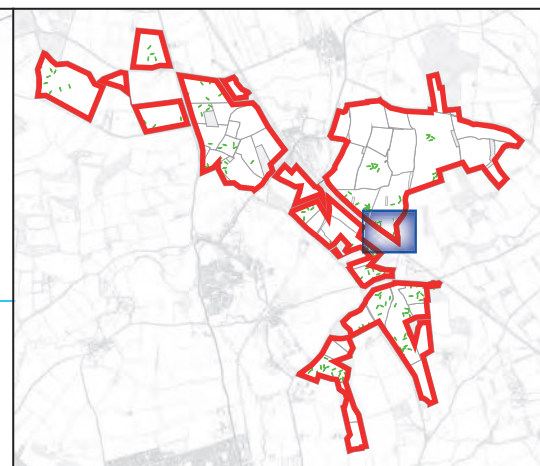
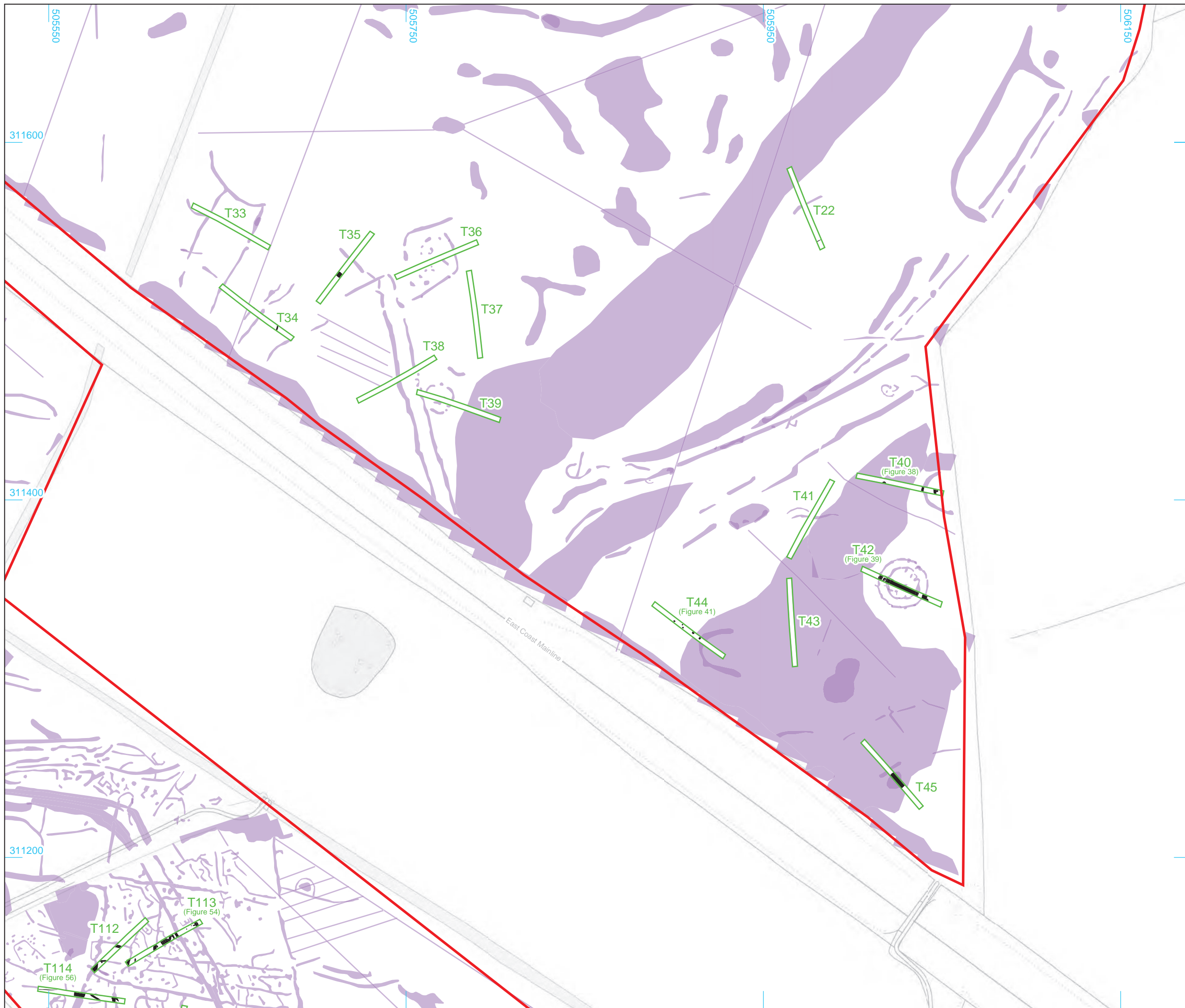

- Site boundary
- Evaluation trench
- Identified feature

Geophysical survey results
(Magnitude Surveys 2022)

- Area
- Trend



© Crown copyright and database rights 2022 Ordnance Survey 0100031673

Cotswold Archaeology

Andover 01264 347630
 Cirencester 01285 771022
 Milton Keynes 01908 564660
 Suffolk 01449 900120
 www.cotswoldarchaeology.co.uk
 enquiries@cotswoldarchaeology.co.uk

PROJECT TITLE
 Mallard Pass Solar Farm DCO,
 Essendine, Rutland & Lincolnshire

FIGURE TITLE
 Trench layout plan (Area M10) showing
 geophysical survey results and
 archaeological features

DRAWN BY	RW	PROJECT NO.	MK0789	FIGURE NO.
CHECKED BY	DJB	DATE	07/02/2023	8
APPROVED BY	AW	SCALE@A3	1:2000	

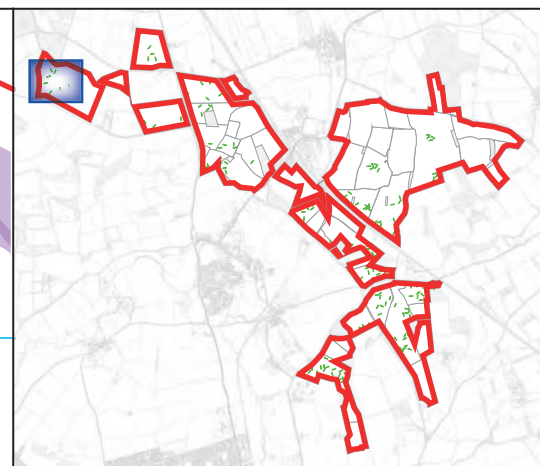

- Site boundary
- Evaluation trench

- Geophysical survey results
(Magnitude Surveys 2022)*
- Area



© Crown copyright and database rights 2022 Ordnance Survey 0100031673

Cotswold Archaeology
 Andover 01264 347630
 Cirencester 01285 771022
 Milton Keynes 01908 564660
 Suffolk 01449 900120
www.cotswoldarchaeology.co.uk
enquiries@cotswoldarchaeology.co.uk

PROJECT TITLE
 Mallard Pass Solar Farm DCO,
 Essendine, Rutland & Lincolnshire

FIGURE TITLE
**Trench layout plan (Area W3) showing
 geophysical survey results and
 archaeological features**

<small>DRAWN BY</small> RW	<small>PROJECT NO.</small> MK0789	<small>FIGURE NO.</small>
<small>CHECKED BY</small> DJB	<small>DATE</small> 07/02/2023	9
<small>APPROVED BY</small> AW	<small>SCALE@A3</small> 1:2000	

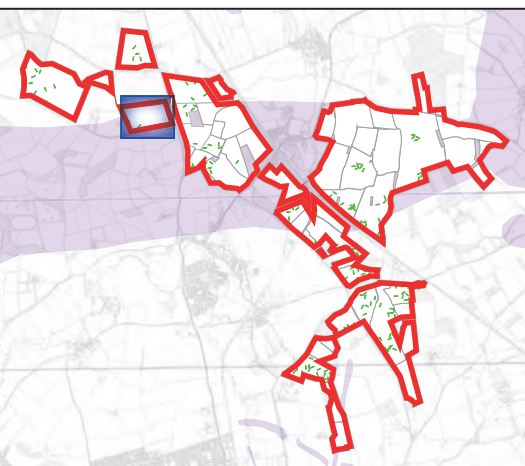

N

- Site boundary
- Evaluation trench
- Identified feature

*Geophysical survey results
(Magnitude Surveys 2022)*

- Area
- Trend



© Crown copyright and database rights 2022 Ordnance Survey 0100031673

Andover 01264 347630
 Cirencester 01285 771022
 Milton Keynes 01908 564660
 Suffolk 01449 900120
www.cotswoldarchaeology.co.uk
enquiries@cotswoldarchaeology.co.uk

PROJECT TITLE
 Mallard Pass Solar Farm DCO,
 Essendine, Rutland & Lincolnshire

FIGURE TITLE
 Trench layout plan (W2) showing
 geophysical survey results and
 archaeological features

<small>DRAWN BY</small> RW	<small>PROJECT NO.</small> MK0789	<small>FIGURE NO.</small>
<small>CHECKED BY</small> DJB	<small>DATE</small> 07/02/2023	10
<small>APPROVED BY</small> AW	<small>SCALE@A3</small> 1:2000	

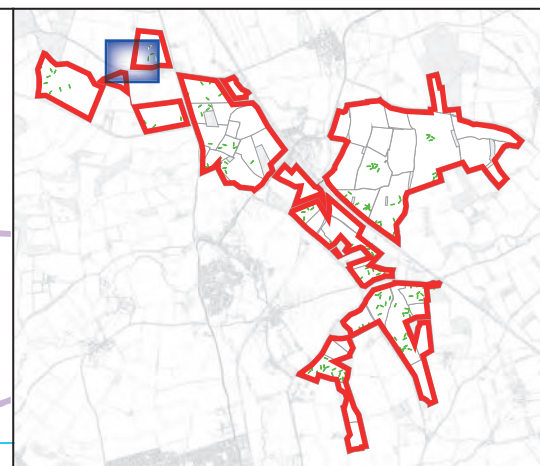

- Site boundary
- Evaluation trench
- Identified feature

Geophysical survey results
(Magnitude Surveys 2022)

- Area
- Trend



© Crown copyright and database rights 2022 Ordnance Survey 0100031673

Cotswold Archaeology

Andover 01264 347630
 Cirencester 01285 771022
 Milton Keynes 01908 564660
 Suffolk 01449 900120
 www.cotswoldarchaeology.co.uk
 enquiries@cotswoldarchaeology.co.uk

PROJECT TITLE
 Mallard Pass Solar Farm DCO,
 Essendine, Rutland & Lincolnshire

FIGURE TITLE
 Trench layout plan (P1 and W1)
 showing geophysical survey results
 and archaeological features

<small>DRAWN BY</small> RW	<small>PROJECT NO.</small> MK0789	<small>FIGURE NO.</small> 11
<small>CHECKED BY</small> DJB	<small>DATE</small> 07/02/2023	
<small>APPROVED BY</small> AW	<small>SCALE</small> @A3 1:2000	

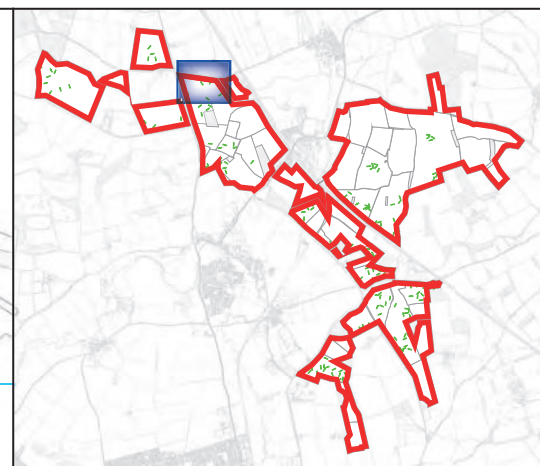
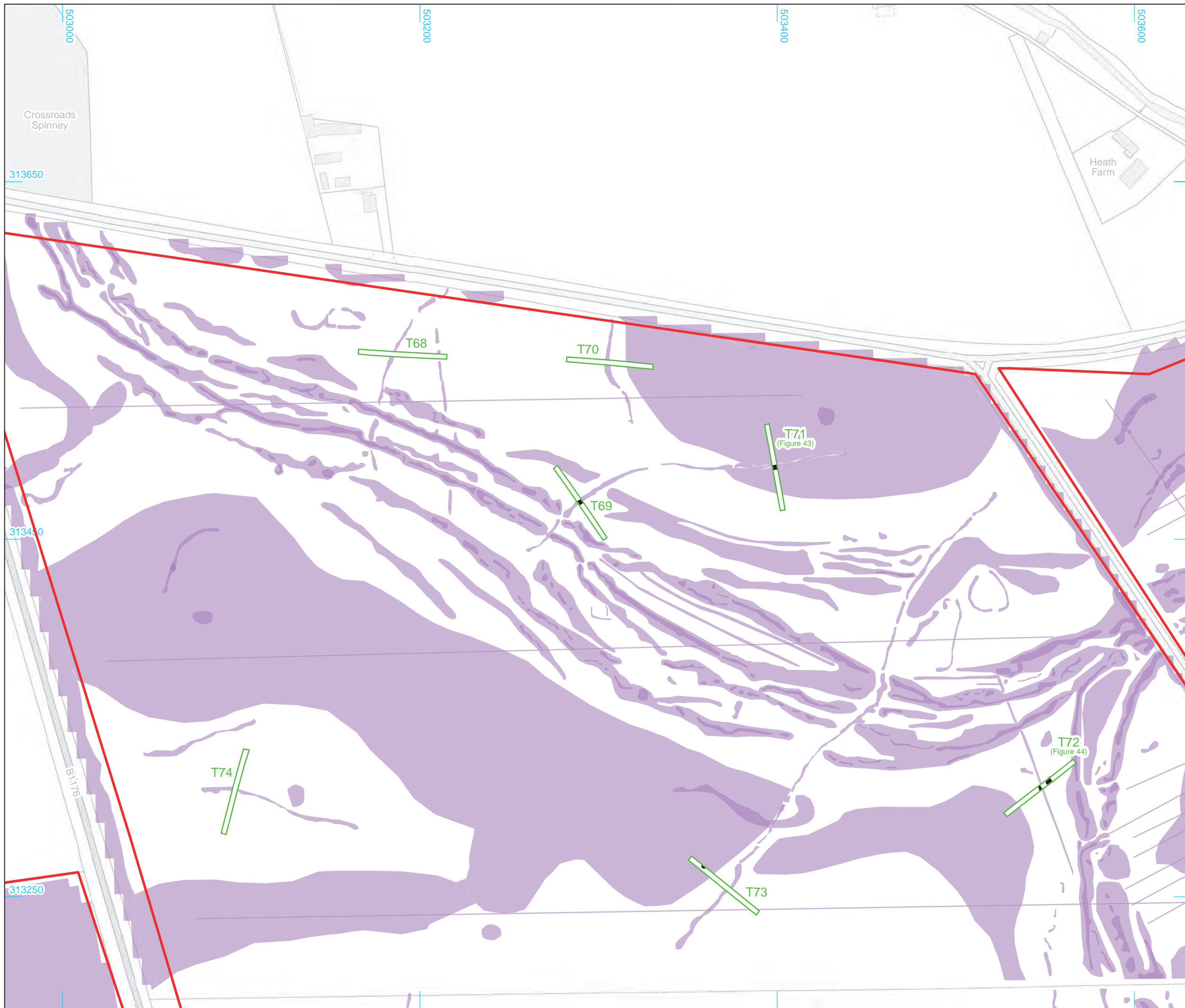

- Site boundary
- Evaluation trench
- Identified feature

Geophysical survey results
(Magnitude Surveys 2022)

- Area
- Trend



© Crown copyright and database rights 2022 Ordnance Survey 0100031673

Cotswold Archaeology
 Andover 01264 347630
 Cirencester 01285 771022
 Milton Keynes 01908 564660
 Suffolk 01449 900120
www.cotswoldarchaeology.co.uk
enquiries@cotswoldarchaeology.co.uk

PROJECT TITLE
**Mallard Pass Solar Farm DCO,
 Essendine, Rutland & Lincolnshire**

FIGURE TITLE
**Trench layout plan (Area P2) showing
 geophysical survey results and
 archaeological features**

DRAWN BY	RW	PROJECT NO.	MK0789	FIGURE NO.
CHECKED BY	DJB	DATE	07/02/2023	12
APPROVED BY	AW	SCALE@A3	1:2000	

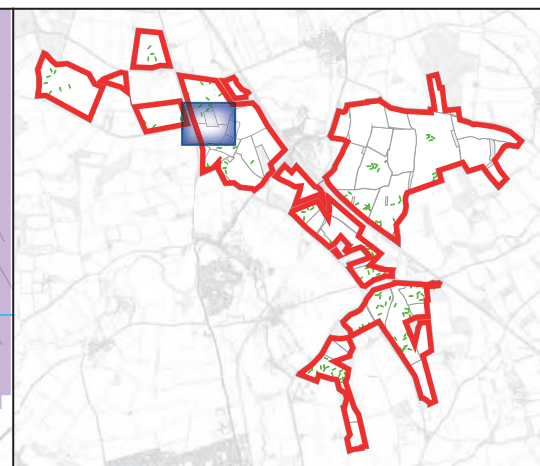

- Site boundary
- Evaluation trench
- Identified feature

*Geophysical survey results
(Magnitude Surveys 2022)*

- Area
- Trend



© Crown copyright and database rights 2022 Ordnance Survey 0100031673

Cotswold Archaeology

Andover 01264 347630
Cirencester 01285 771022
Milton Keynes 01908 564660
Suffolk 01449 900120
www.cotswoldarchaeology.co.uk
enquiries@cotswoldarchaeology.co.uk

PROJECT TITLE
 Mallard Pass Solar Farm DCO,
 Essendine, Rutland & Lincolnshire

FIGURE TITLE
 Trench layout plan (Area P3 and P6)
 showing geophysical survey results
 and archaeological features

DRAWN BY	RW	PROJECT NO.	MK0789	FIGURE NO.
CHECKED BY	DJB	DATE	07/02/2023	13
APPROVED BY	AW	SCALE@A3	1:2000	

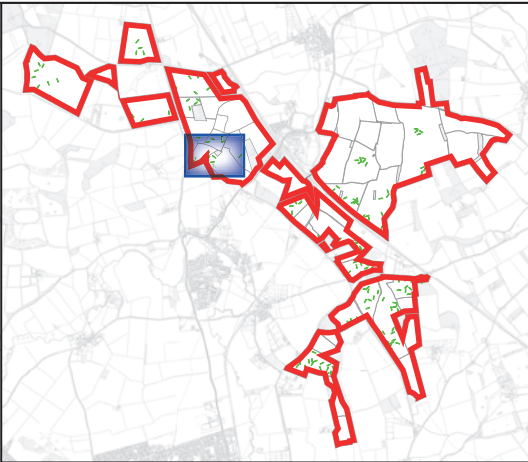

N

Site boundary
Evaluation trench
Identified feature

Geophysical survey results (Magnitude Surveys 2022)
Area
Trend

0 1:2000 100m

© Crown copyright and database rights 2022 Ordnance Survey 0100031673

Cotswold Archaeology
 Andover 01264 347630
 Cirencester 01285 771022
 Milton Keynes 01908 564660
 Suffolk 01449 900120
 www.cotswoldarchaeology.co.uk
 enquiries@cotswoldarchaeology.co.uk

PROJECT TITLE
 Mallard Pass Solar Farm DCO,
 Essendine, Rutland & Lincolnshire

FIGURE TITLE
Trench layout plan (Area P3 and P6)
showing geophysical survey results
and archaeological features

DRAWN BY	RW	PROJECT NO.	MK0789	FIGURE NO.
CHECKED BY	DJB	DATE	07/02/2023	14
APPROVED BY	AW	SCALE@A3	1:2000	

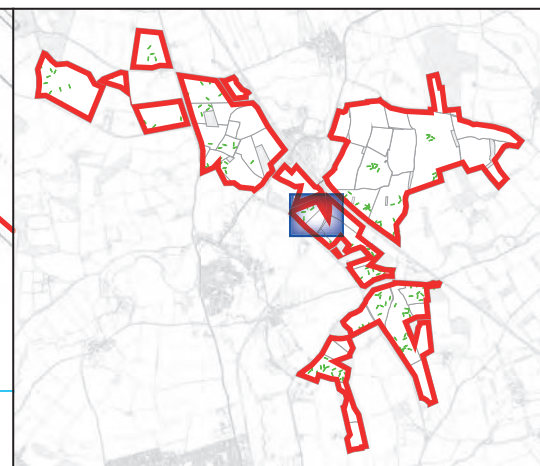
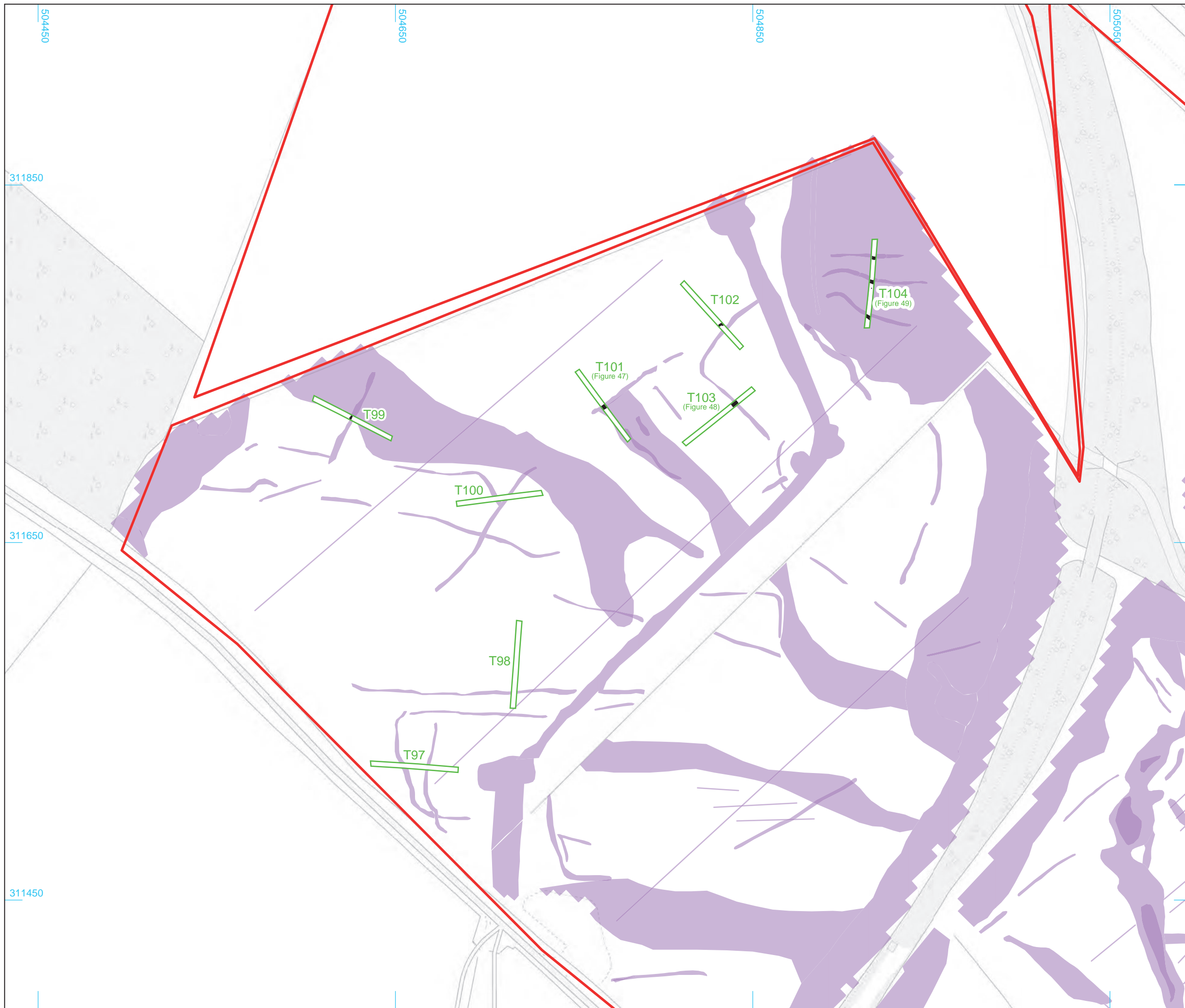

- Site boundary
- Evaluation trench
- Identified feature

*Geophysical survey results
(Magnitude Surveys 2022)*

- Area
- Trend



© Crown copyright and database rights 2022 Ordnance Survey 0100031673

Andover 01264 347630
Cirencester 01285 771022
Milton Keynes 01908 564660
Suffolk 01449 900120
www.cotswoldarchaeology.co.uk
enquiries@cotswoldarchaeology.co.uk

PROJECT TITLE
Mallard Pass Solar Farm DCO,
Essendine, Rutland & Lincolnshire

FIGURE TITLE
**Trench layout plan (Areas PF1–2)
showing geophysical survey results
and archaeological features**

<small>DRAWN BY</small> RW	<small>PROJECT NO.</small> MK0789	<small>FIGURE NO.</small>
<small>CHECKED BY</small> DJB	<small>DATE</small> 07/02/2023	15
<small>APPROVED BY</small> AW	<small>SCALE@A3</small> 1:2000	

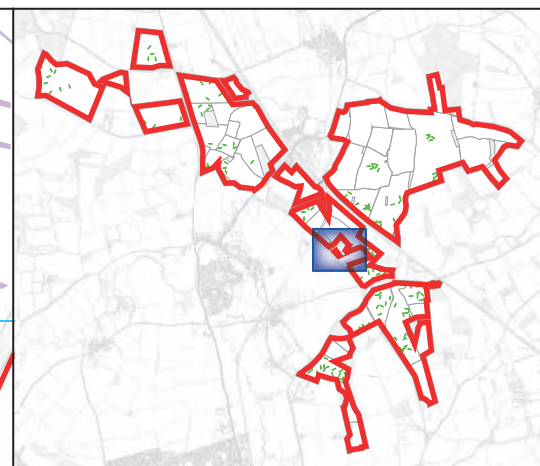

N

- Site boundary
- Evaluation trench
- Identified feature

*Geophysical survey results
(Magnitude Surveys 2022)*

- Area
- Trend



© Crown copyright and database rights 2022 Ordnance Survey 0100031673

Cotswold Archaeology

- Andover 01264 347630
- Cirencester 01285 771022
- Milton Keynes 01908 564660
- Suffolk 01449 900120
- www.cotswoldarchaeology.co.uk
- enquiries@cotswoldarchaeology.co.uk

PROJECT TITLE
Mallard Pass Solar Farm DCO,
Essendine, Rutland & Lincolnshire

FIGURE TITLE
Trench layout plan (Areas PF4–6)
showing geophysical survey results
and archaeological features

DRAWN BY	RW	PROJECT NO.	MK0789	FIGURE NO.
CHECKED BY	DJB	DATE	07/02/2023	16
APPROVED BY	AW	SCALE@A3	1:2000	

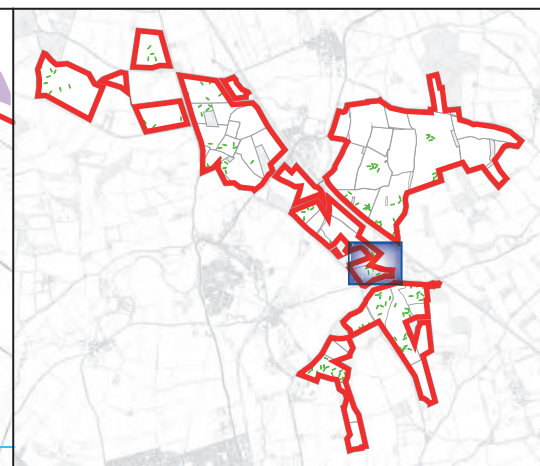
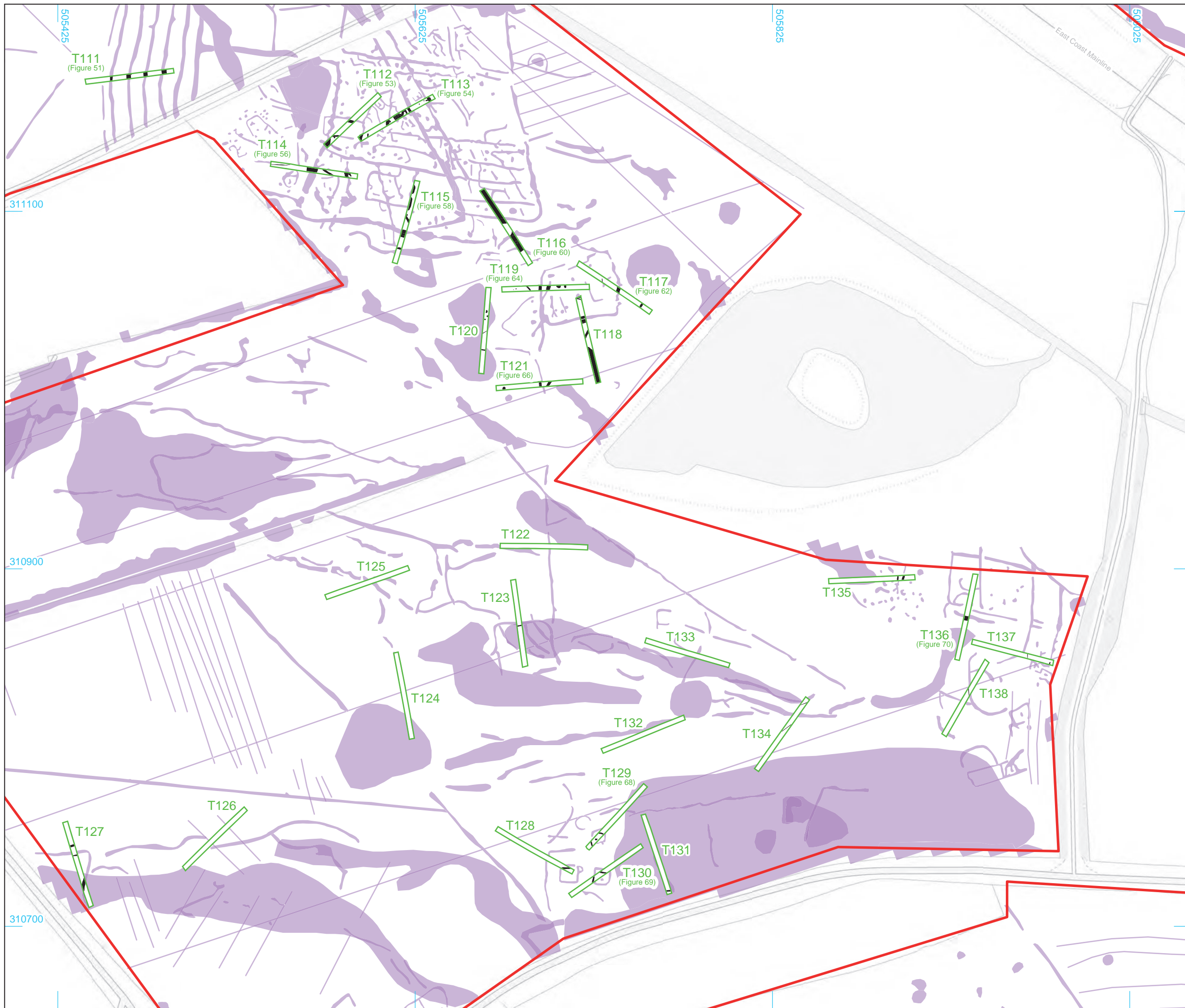

- Site boundary
- Evaluation trench
- Identified feature

*Geophysical survey results
(Magnitude Surveys 2022)*

- Area
- Trend



© Crown copyright and database rights 2022 Ordnance Survey 0100031673

Cotswold Archaeology

Andover 01264 347630
 Cirencester 01285 771022
 Milton Keynes 01908 564660
 Suffolk 01449 900120
 www.cotswoldarchaeology.co.uk
 enquiries@cotswoldarchaeology.co.uk

PROJECT TITLE
 Mallard Pass Solar Farm DCO,
 Essendine, Rutland & Lincolnshire

FIGURE TITLE
 Trench layout plan (Areas PF7-8)
 showing geophysical survey results
 and archaeological features

DRAWN BY	RW	PROJECT NO.	MK0789	FIGURE NO.
CHECKED BY	DJB	DATE	07/02/2023	17
APPROVED BY	AW	SCALE@A3	1:2000	

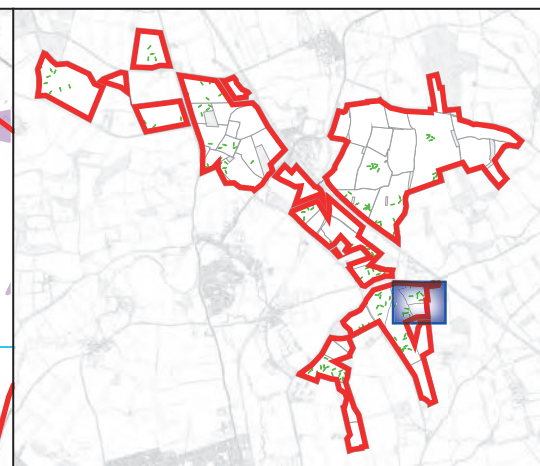
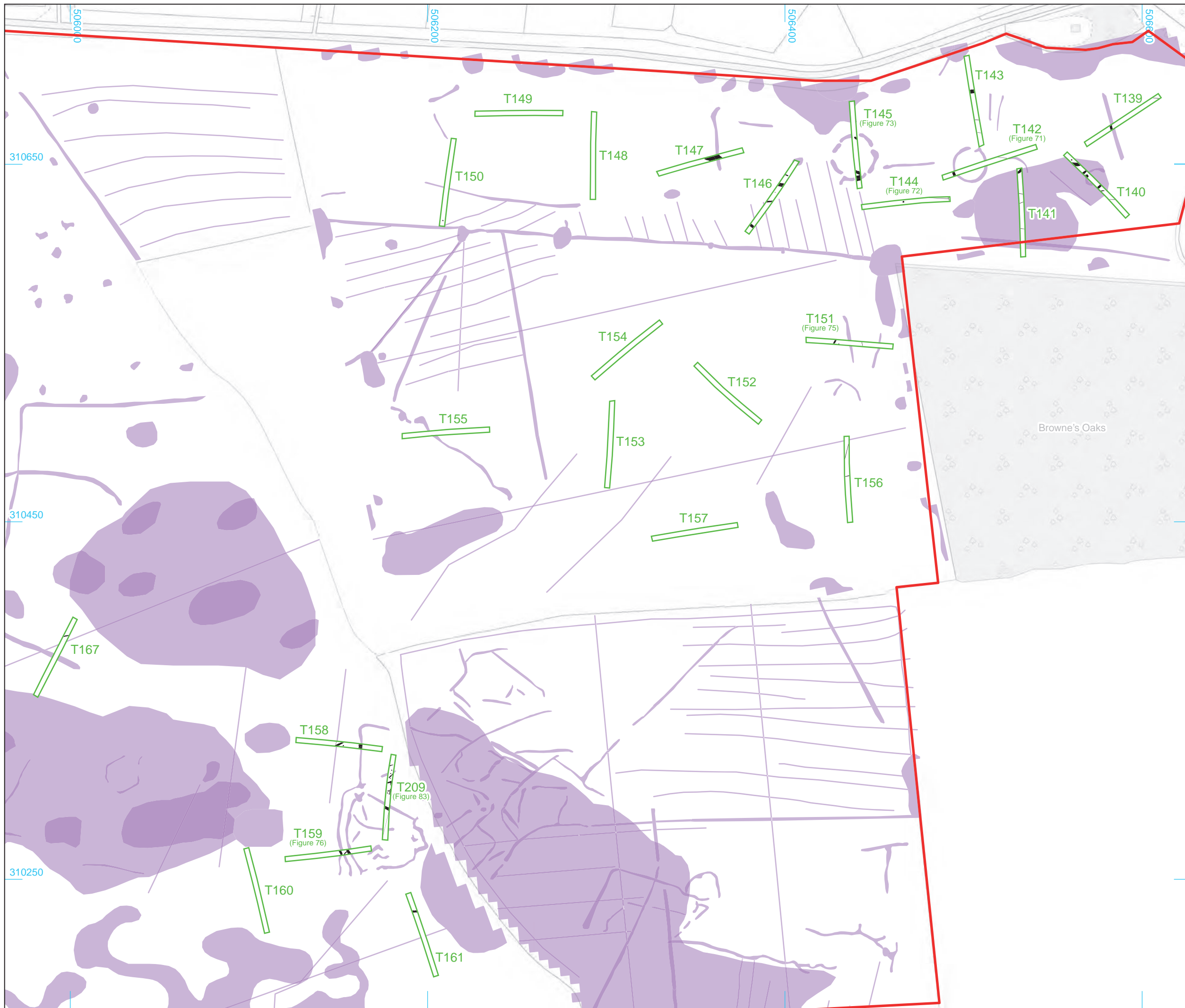

- Site boundary
- Evaluation trench
- Identified feature

*Geophysical survey results
(Magnitude Surveys 2022)*

- Area
- Trend

Browne's Oaks



© Crown copyright and database rights 2022 Ordnance Survey 0100031673

Andover 01264 347630
Cirencester 01285 771022
Milton Keynes 01908 564660
Suffolk 01449 900120
www.cotswoldarchaeology.co.uk
enquiries@cotswoldarchaeology.co.uk

PROJECT TITLE
Mallard Pass Solar Farm DCO,
Essendine, Rutland & Lincolnshire

FIGURE TITLE
**Trench layout plan (Areas N8 (north),
N11-12) showing geophysical survey
results and archaeological features**

<small>DRAWN BY</small> RW	<small>PROJECT NO.</small> MK0789	<small>FIGURE NO.</small>
<small>CHECKED BY</small> DJB	<small>DATE</small> 07/02/2023	18
<small>APPROVED BY</small> AW	<small>SCALE</small> @A3 1:2000	

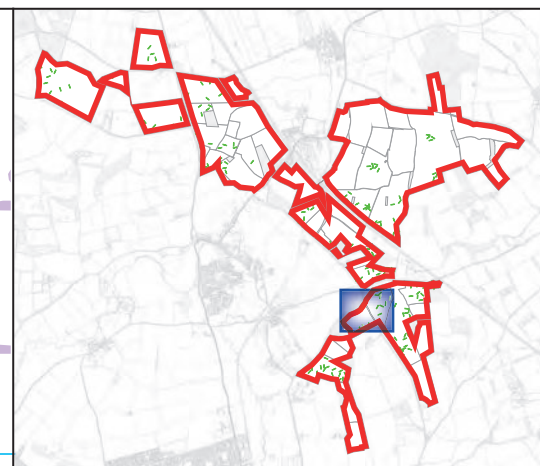

- Site boundary
- Evaluation trench
- Identified feature

Geophysical survey results
(Magnitude Surveys 2022)

- Area
- Trend



© Crown copyright and database rights 2022 Ordnance Survey 0100031673

Cotswold Archaeology

Andover 01264 347630
 Cirencester 01285 771022
 Milton Keynes 01908 564660
 Suffolk 01449 900120
www.cotswoldarchaeology.co.uk
enquiries@cotswoldarchaeology.co.uk

PROJECT TITLE
Mallard Pass Solar Farm DCO,
Essendine, Rutland & Lincolnshire

FIGURE TITLE
Trench layout plan (Areas N7-7)
showing geophysical survey results
and archaeological features

<small>DRAWN BY</small> RW	<small>PROJECT NO.</small> MK0789	<small>FIGURE NO.</small>
<small>CHECKED BY</small> DJB	<small>DATE</small> 07/02/2023	19
<small>APPROVED BY</small> AW	<small>SCALE</small> @A3 1:2000	

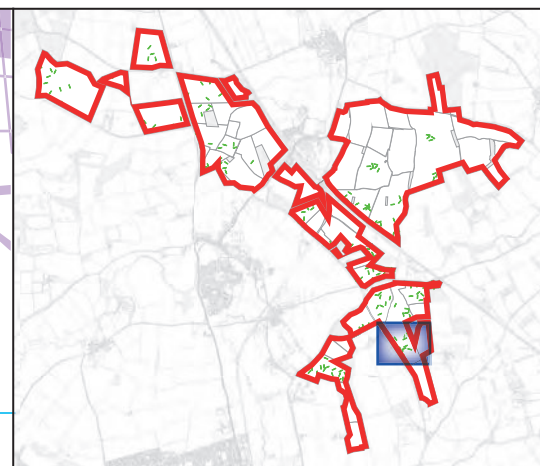
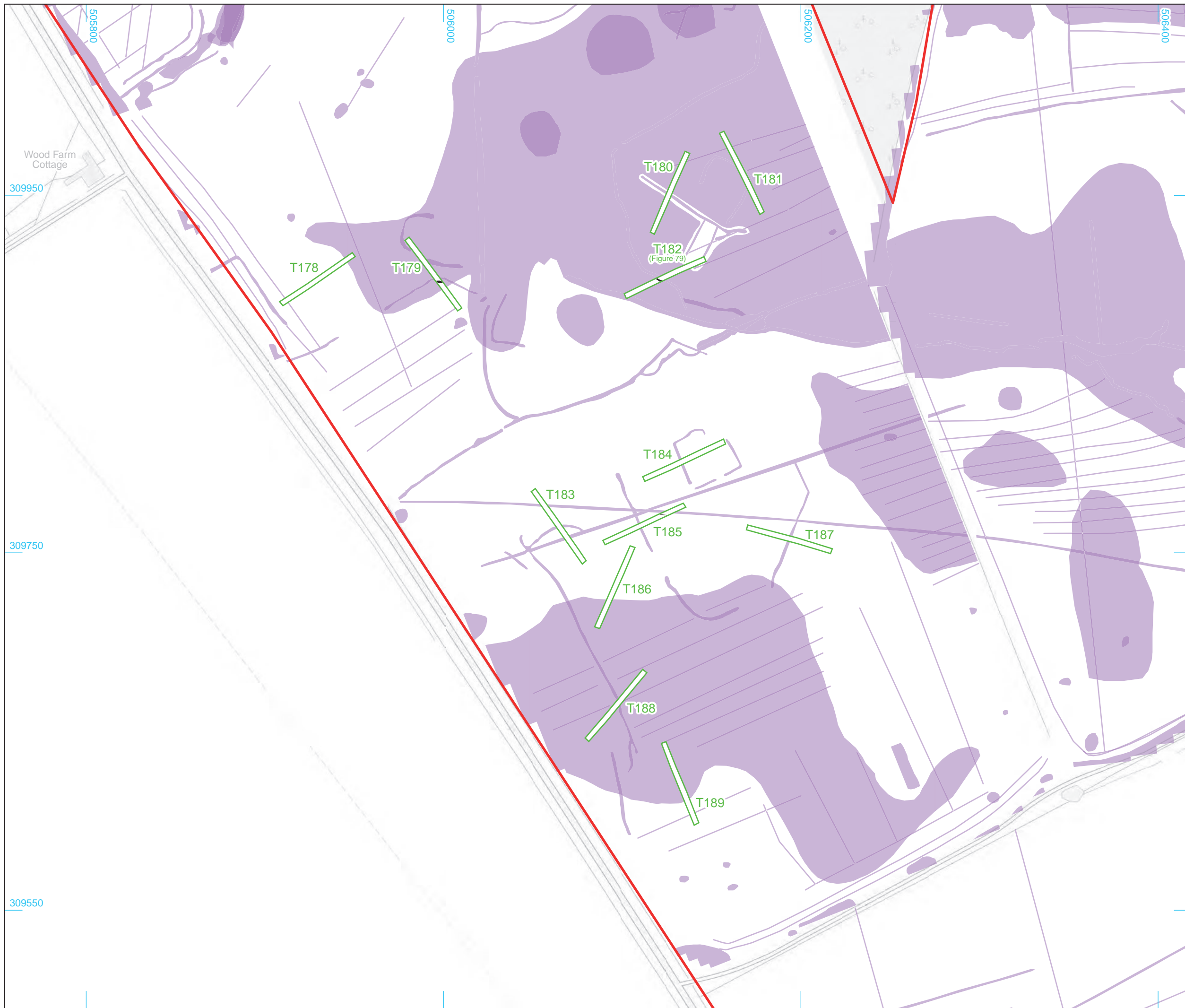

- Site boundary
- Evaluation trench
- Identified feature

Geophysical survey results
(Magnitude Surveys 2022)

- Area
- Trend



© Crown copyright and database rights 2022 Ordnance Survey 0100031673

Cotswold Archaeology

Andover 01264 347630
 Cirencester 01285 771022
 Milton Keynes 01908 564660
 Suffolk 01449 900120
www.cotswoldarchaeology.co.uk
enquiries@cotswoldarchaeology.co.uk

PROJECT TITLE
 Mallard Pass Solar Farm DCO,
 Essendine, Rutland & Lincolnshire

FIGURE TITLE
 Trench layout plan (Area N8 (south))
 showing geophysical survey results
 and archaeological features

<small>DRAWN BY</small> RW	<small>PROJECT NO.</small> MK0789	<small>FIGURE NO.</small>
<small>CHECKED BY</small> DJB	<small>DATE</small> 07/02/2023	20
<small>APPROVED BY</small> AW	<small>SCALE@A3</small> 1:2000	

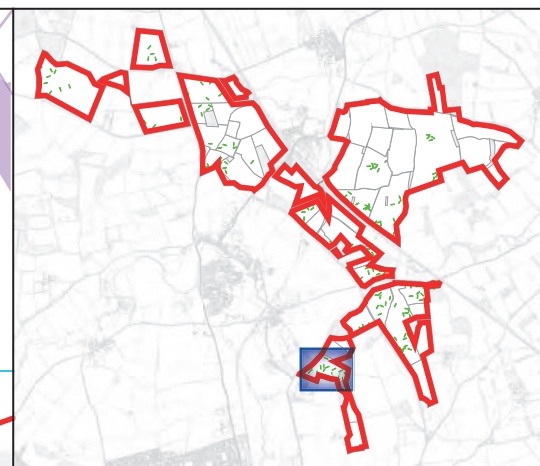
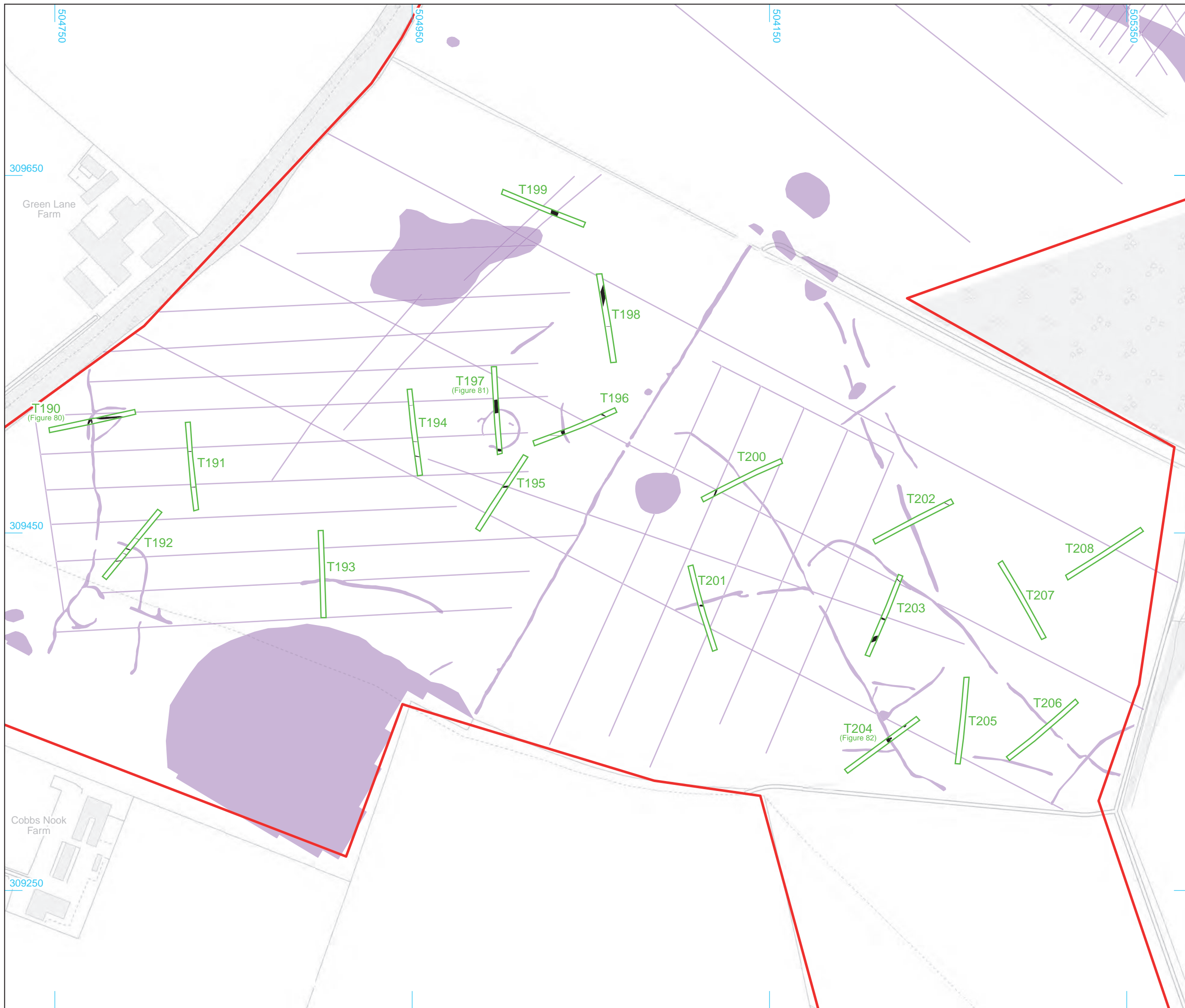

- Site boundary
- Evaluation trench
- Identified feature

*Geophysical survey results
(Magnitude Surveys 2022)*

- Area
- Trend



© Crown copyright and database rights 2022 Ordnance Survey 0100031673

Andover 01264 347630
Cirencester 01285 771022
Milton Keynes 01908 564660
Suffolk 01449 900120
www.cotswoldarchaeology.co.uk
enquiries@cotswoldarchaeology.co.uk

PROJECT TITLE
Mallard Pass Solar Farm DCO,
Essendine, Rutland & Lincolnshire

FIGURE TITLE
**Trench layout plan (Area N3) showing
geophysical survey results and
archaeological features**

<small>DRAWN BY</small> RW	<small>PROJECT NO.</small> MK0789	<small>FIGURE NO.</small>
<small>CHECKED BY</small> DJB	<small>DATE</small> 07/02/2023	21
<small>APPROVED BY</small> AW	<small>SCALE@A3</small> 1:2000	



Trench 11, looking east (1m scales)



Trench 21, looking south-east (1m scales)



Trench 33, looking south-east (1m scales)



Trench 54, looking north-west (1m scales)

 Andover 01264 347630
 Cirencester 01285 771022
 Milton Keynes 01908 564660
 Suffolk 01449 900120
www.cotswoldarchaeology.co.uk
enquiries@cotswoldarchaeology.co.uk

PROJECT TITLE
 Mallard Pass Solar Farm DCO,
 Essendine, Rutland & Lincolnshire

FIGURE TITLE
 Selection of blank trenches in Rutland:
 photographs

DRAWN BY	RW	PROJECT NO.	MK0789	FIGURE NO.
CHECKED BY	DJB	DATE	07/02/2023	22
APPROVED BY	AW	SCALE@A3	NA	



Trench 66, looking north (1m scales)



Trench 98, looking north-west (1m scales)



Trench 100, looking south-west (1m scales)



Trench 134, looking south-west (1m scales)

 Andover 01264 347630
 Cirencester 01285 771022
 Milton Keynes 01908 564660
 Suffolk 01449 900120
www.cotswoldarchaeology.co.uk
enquiries@cotswoldarchaeology.co.uk

PROJECT TITLE
 Mallard Pass Solar Farm DCO,
 Essendine, Rutland & Lincolnshire

FIGURE TITLE
**Selection of blank trenches in Rutland:
 photographs**

DRAWN BY	RW	PROJECT NO.	MK0789	FIGURE NO.
CHECKED BY	DJB	DATE	07/02/2023	
APPROVED BY	AW	SCALE	@A3	23



Trench 10, looking south-west



Trench 11, looking east (1m scales)



Trench 138, looking south-east (1m scales)



Trench 168, looking south (1m scales)

Cotswold Archaeology
 Andover 01264 347630
 Cirencester 01285 771022
 Milton Keynes 01908 564660
 Suffolk 01449 900120
 www.cotswoldarchaeology.co.uk
 enquiries@cotswoldarchaeology.co.uk

PROJECT TITLE
 Mallard Pass Solar Farm DCO,
 Essendine, Rutland & Lincolnshire

FIGURE TITLE
 Selection of blank trenches in
 Lincolnshire: photographs

DRAWN BY	RW	PROJECT NO.	MK0789	FIGURE NO.
CHECKED BY	DJB	DATE	07/02/2023	24
APPROVED BY	AW	SCALE@A3	NA	



Trench 175, looking south (1m scales)



Trench 191, looking south-east (1m scales)



Trench 200, looking south-west (1m scales)



Trench 205, looking north (1m scales)

Cotswold Archaeology
 Andover 01264 347630
 Cirencester 01285 771022
 Milton Keynes 01908 564660
 Suffolk 01449 900120
 www.cotswoldarchaeology.co.uk
 enquiries@cotswoldarchaeology.co.uk

PROJECT TITLE
 Mallard Pass Solar Farm DCO,
 Essendine, Rutland & Lincolnshire

FIGURE TITLE
**Selection of blank trenches in
 Lincolnshire: photographs**

DRAWN BY	RW	PROJECT NO.	MK0789	FIGURE NO.
CHECKED BY	DJB	DATE	07/02/2023	25
APPROVED BY	AW	SCALE	A3	

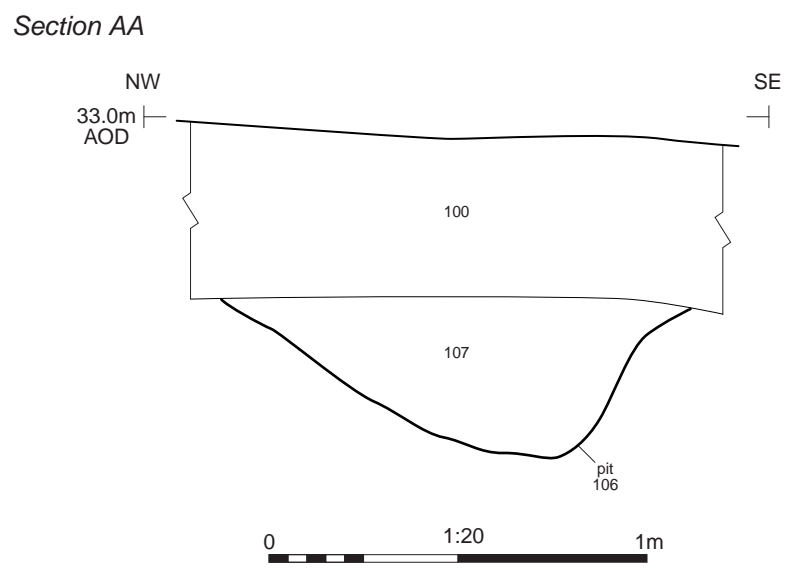
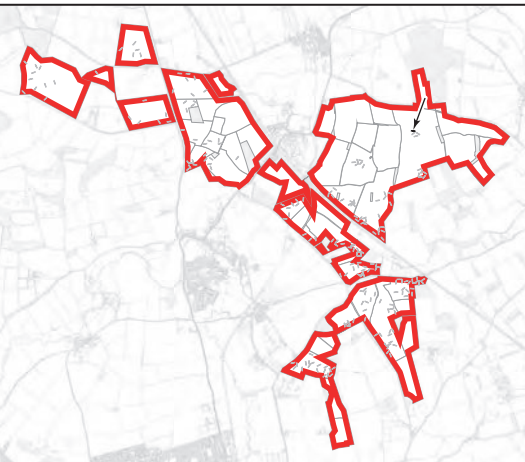
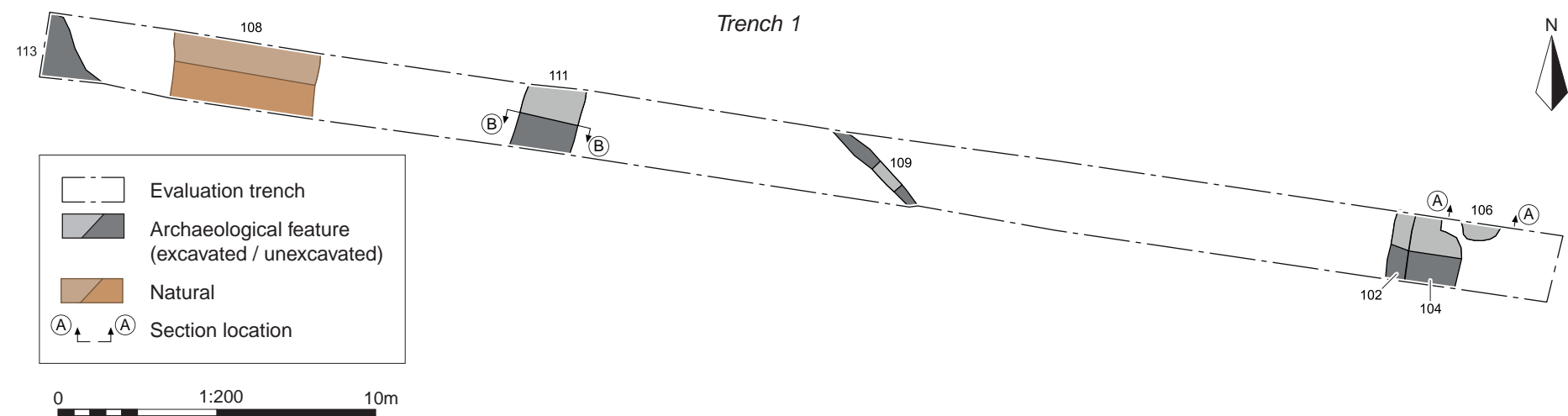

Trench 1, looking south-east



Pit 106, looking north-east (1m scale)

Cotswold Archaeology

Andover 01264 347630
 Cirencester 01285 771022
 Milton Keynes 01908 564660
 Suffolk 01449 900120
 www.cotswoldarchaeology.co.uk
 enquiries@cotswoldarchaeology.co.uk

PROJECT TITLE
 Mallard Pass Solar Farm DCO,
 Essendine, Rutland & Lincolnshire

FIGURE TITLE
 Area M11 (Lincolnshire), Trench 1:
 plan, sections and photographs

DRAWN BY RW **PROJECT NO.** MK0789 **FIGURE NO.**
CHECKED BY DJB **DATE** 07/02/2023 **26**
APPROVED BY AW **SCALE@A3** 1:200, 1:20

Section BB

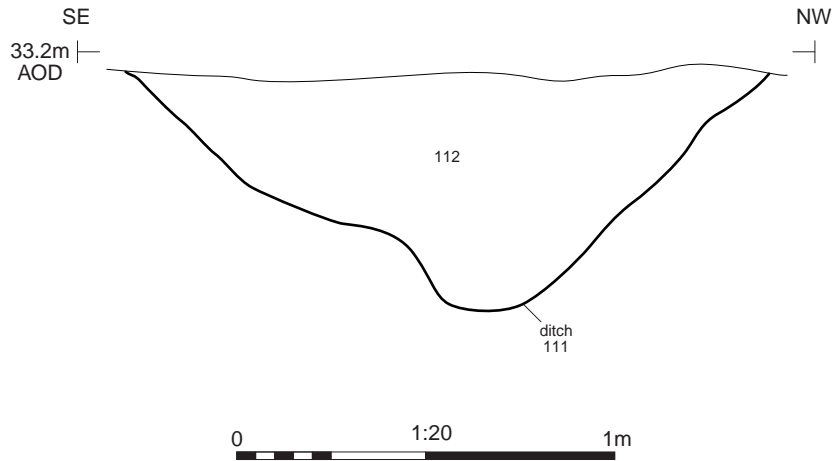

Ditch 111, looking north-east (1m scale)



Andover 01264 347630
Cirencester 01285 771022
Milton Keynes 01908 564660
Suffolk 01449 900120
www.cotswoldarchaeology.co.uk
enquiries@cotswoldarchaeology.co.uk

PROJECT TITLE

Mallard Pass Solar Farm DCO,
Essendine, Rutland & Lincolnshire

FIGURE TITLE

Area M11 (Lincolnshire), Trench 1:
section and photograph

DRAWN BY RW PROJECT NO. MK0789
CHECKED BY DJB DATE 07/02/2023
APPROVED BY AW SCALE@A4 1:20

FIGURE NO.

27



Trench 2

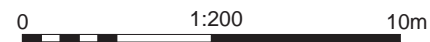
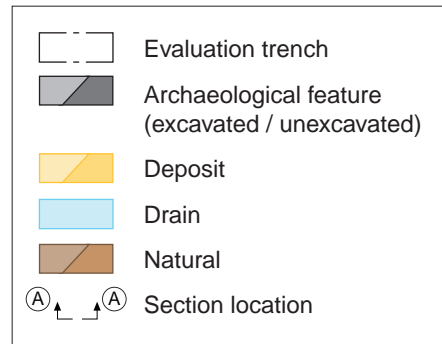
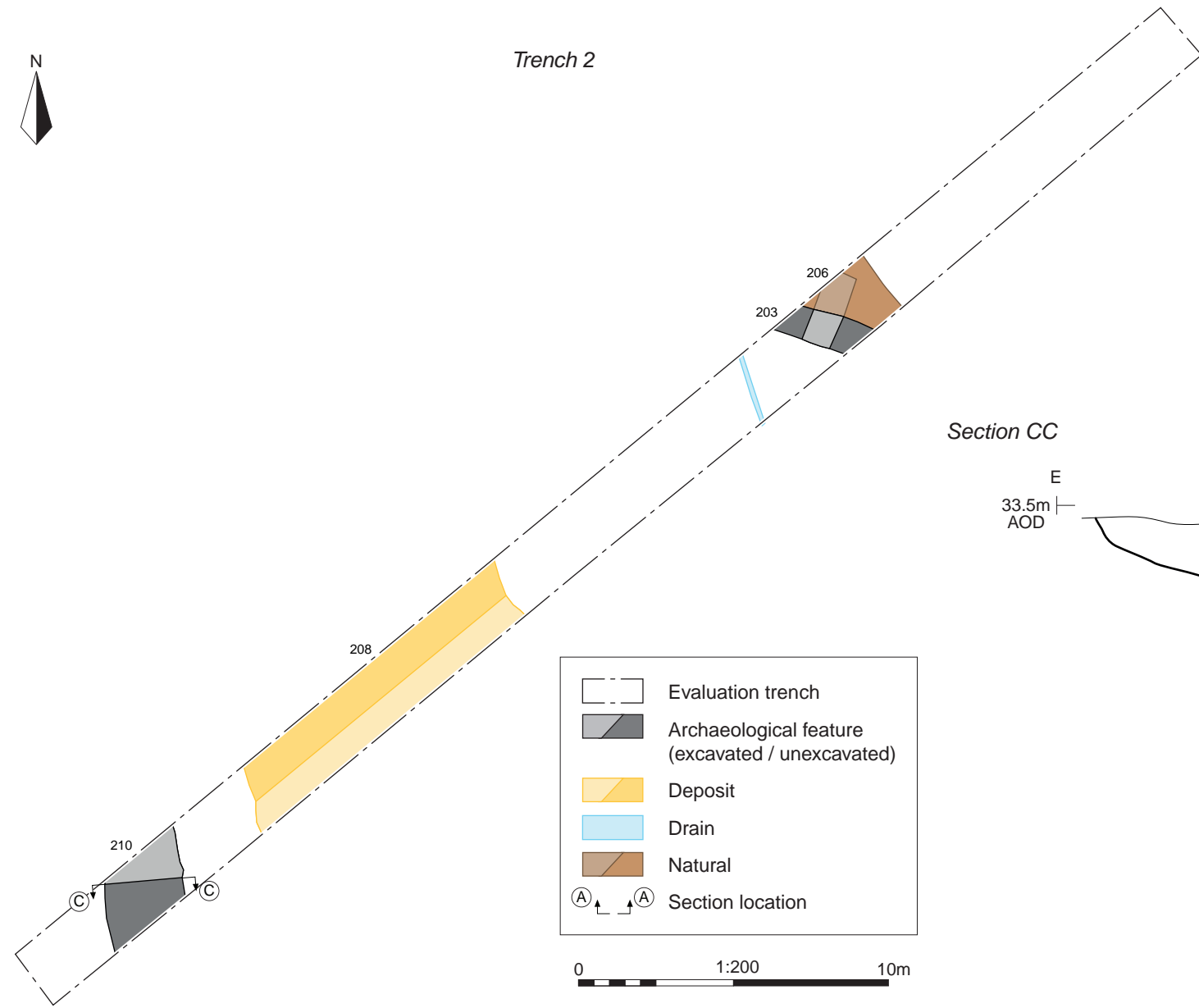

Section CC

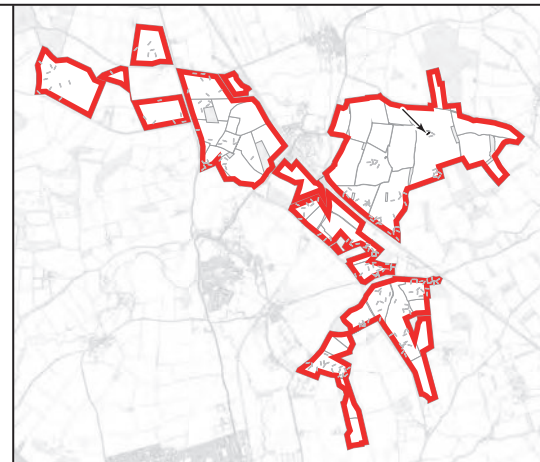
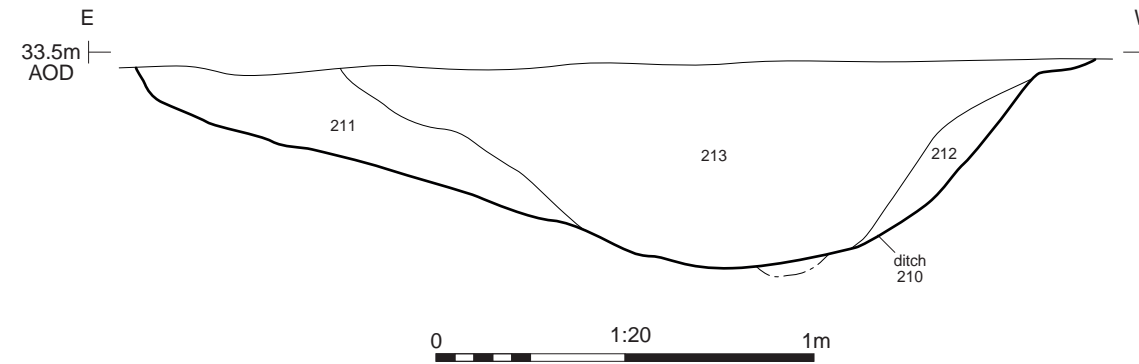

Ditch 210, looking south (1m scale)

Andover 01264 347630
 Cirencester 01285 771022
 Milton Keynes 01908 564660
 Suffolk 01449 900120
www.cotswoldarchaeology.co.uk
enquiries@cotswoldarchaeology.co.uk

PROJECT TITLE
 Mallard Pass Solar Farm DCO,
 Essendine, Rutland & Lincolnshire



FIGURE TITLE
 Area M11 (Lincolnshire), Trench 2:
 plan, section and photographs

DRAWN BY	RW	PROJECT NO.	MK0789	FIGURE NO.
CHECKED BY	DJB	DATE	07/02/2023	28
APPROVED BY	AW	SCALE@A3	1:200, 1:20	

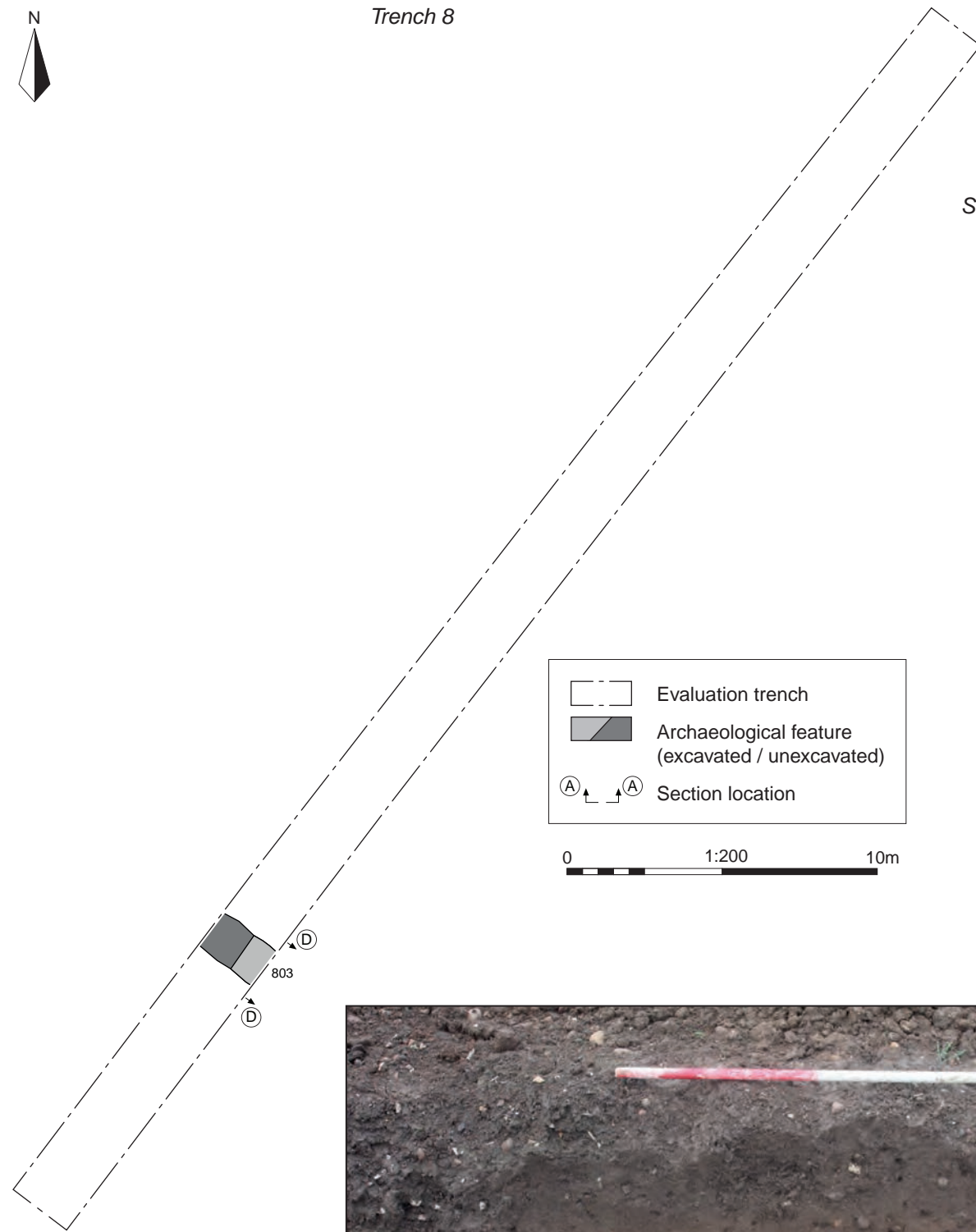

Trench 8



-  Evaluation trench
-  Archaeological feature (excavated / unexcavated)
-  Section location

0 1:200 10m

Section DD

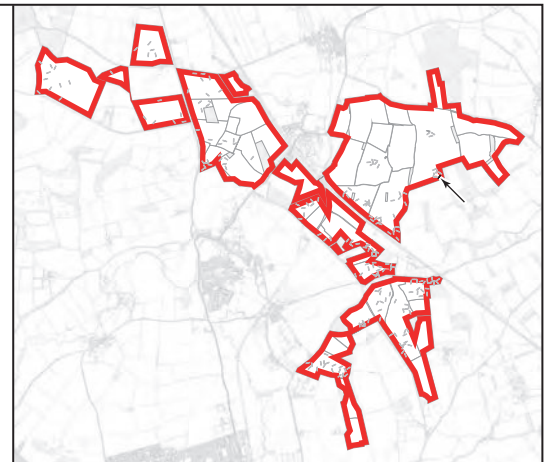
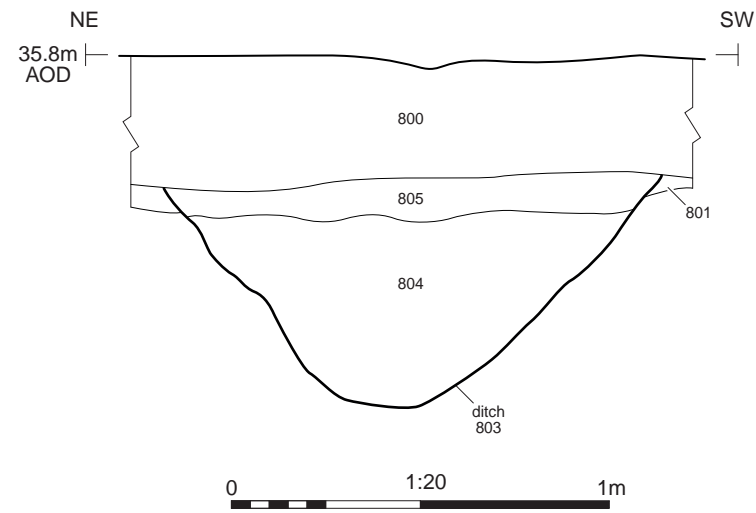

Ditch 802, looking south-east (1m scale)



Trench 8, looking north-east

Cotswold Archaeology
 Andover 01264 347630
 Cirencester 01285 771022
 Milton Keynes 01908 564660
 Suffolk 01449 900120
www.cotswoldarchaeology.co.uk
enquiries@cotswoldarchaeology.co.uk

PROJECT TITLE
Mallard Pass Solar Farm DCO,
Essendine, Rutland & Lincolnshire

FIGURE TITLE
Area M11 (Lincolnshire), Trench 8:
plan, section and photographs

DRAWN BY	RW	PROJECT NO.	MK0789	FIGURE NO.
CHECKED BY	DJB	DATE	07/02/2023	29
APPROVED BY	AW	SCALE@A3	1:200, 1:20	



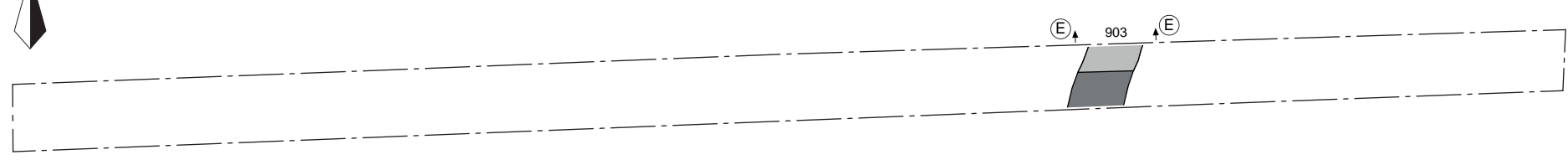

Trench 9

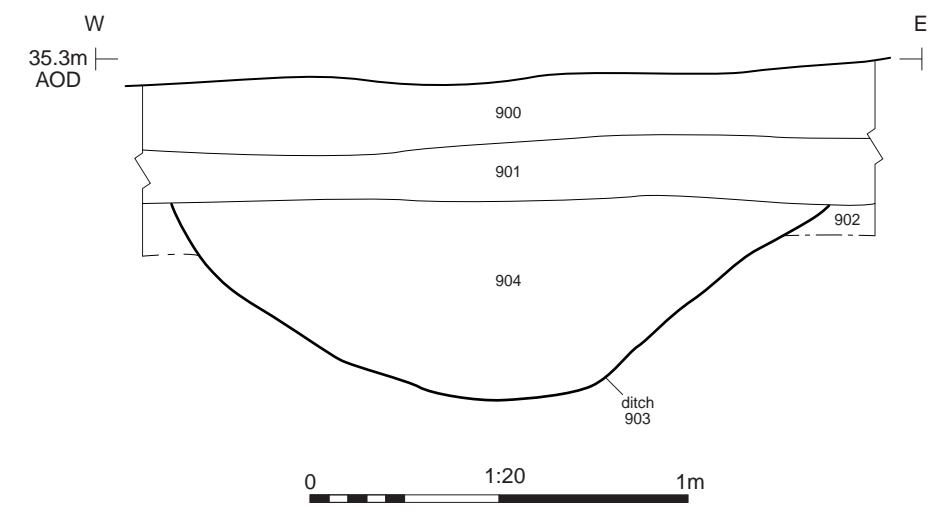

Section EE



 Evaluation trench
 Archaeological feature (excavated / unexcavated)
 Section location

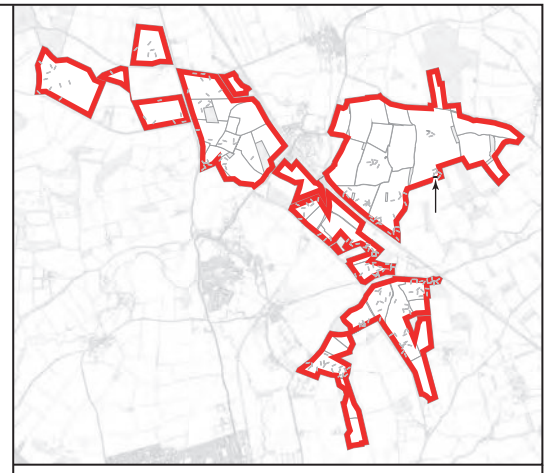

Ditch 903, looking north (1m scale)



Trench 9, looking east



 Andover 01264 347630
 Cirencester 01285 771022
 Milton Keynes 01908 564660
 Suffolk 01449 900120
www.cotswoldarchaeology.co.uk
enquiries@cotswoldarchaeology.co.uk

PROJECT TITLE
Mallard Pass Solar Farm DCO,
Essendine, Rutland & Lincolnshire

FIGURE TITLE
**Area M11 (Lincolnshire), Trench 9:
plan, section and photographs**

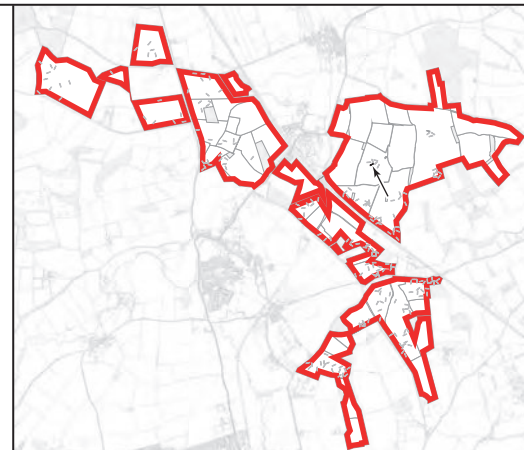
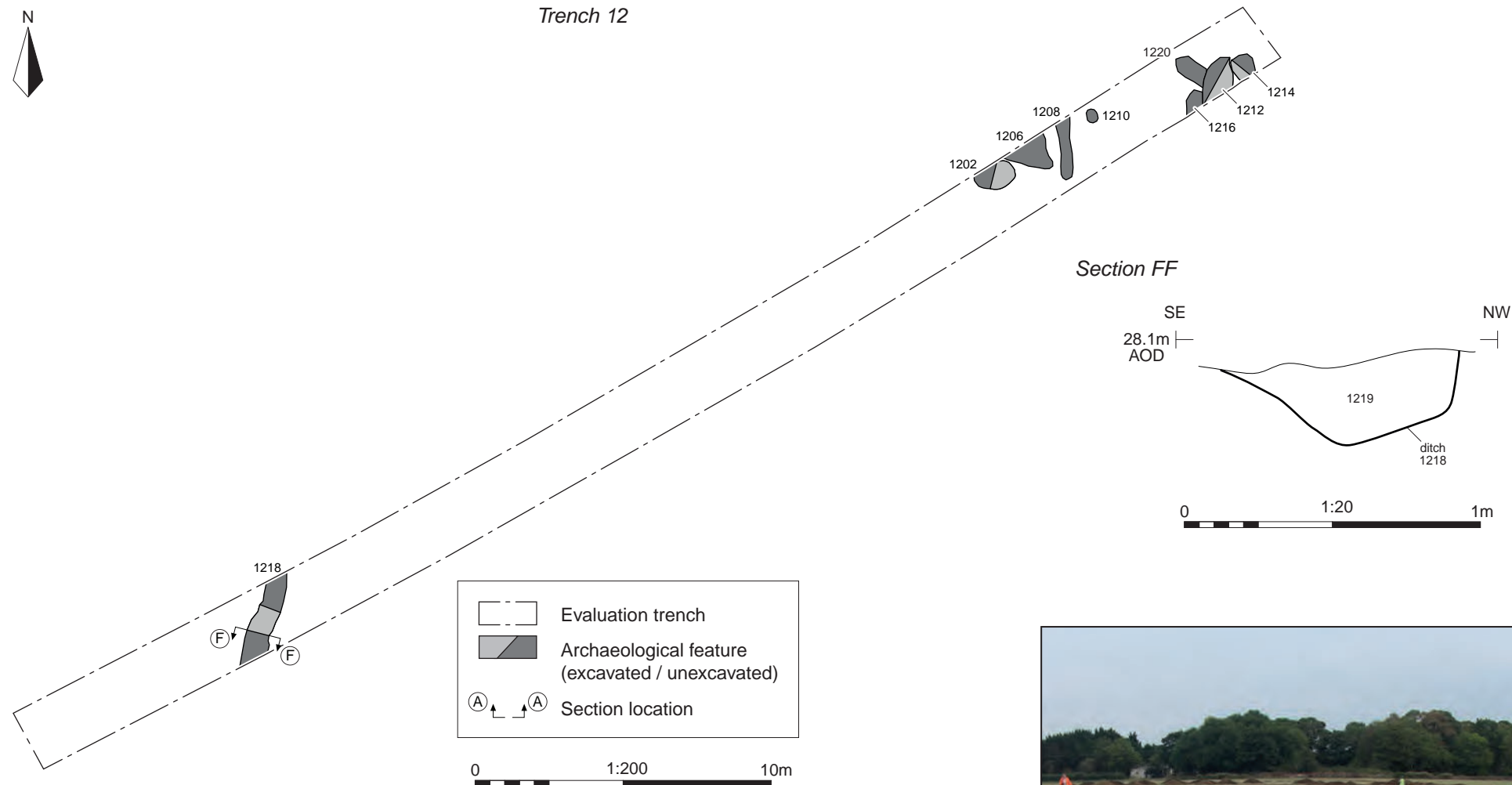

Trench 12



Trench 12, looking north-east (1m scales)



Ditch 1218, looking south-west (0.5m scale)

Andover 01264 347630
 Cirencester 01285 771022
 Milton Keynes 01908 564660
 Suffolk 01449 900120
www.cotswoldarchaeology.co.uk
enquiries@cotswoldarchaeology.co.uk

PROJECT TITLE
 Mallard Pass Solar Farm DCO,
 Essendine, Rutland & Lincolnshire

FIGURE TITLE
 Area M6 (Rutland), Trench 12: plan,
 section and photographs

DRAWN BY	RW	PROJECT NO.	MK0789	FIGURE NO.
CHECKED BY	DJB	DATE	07/02/2023	31
APPROVED BY	AW	SCALE@A3	1:200, 1:20	

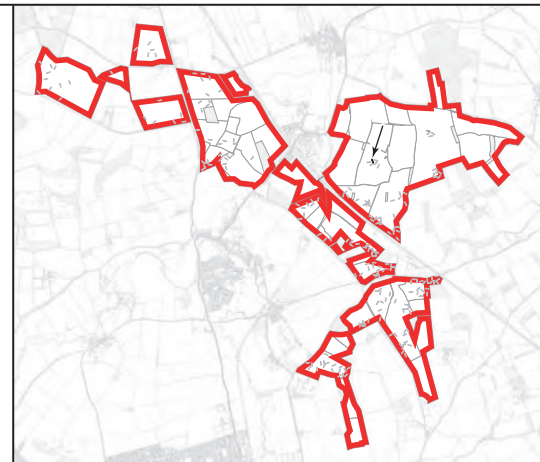

Section GG

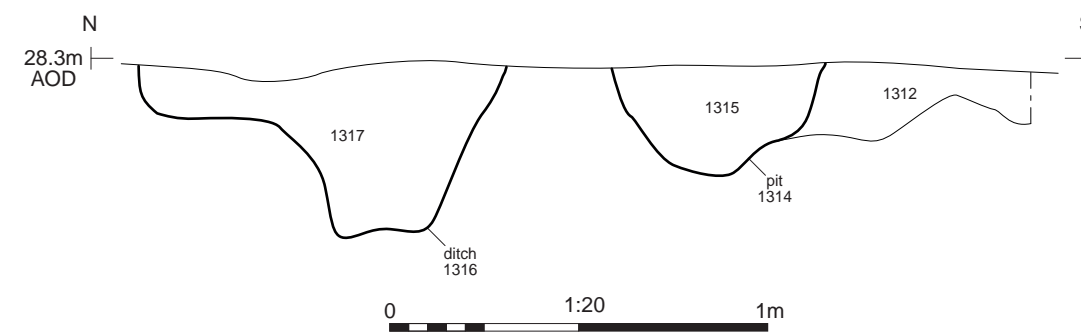

Trench 13, looking north-west (1m scales)



Ditch 1316 (left) and pit 1314 (right), looking east (1m scale)

Trench 13

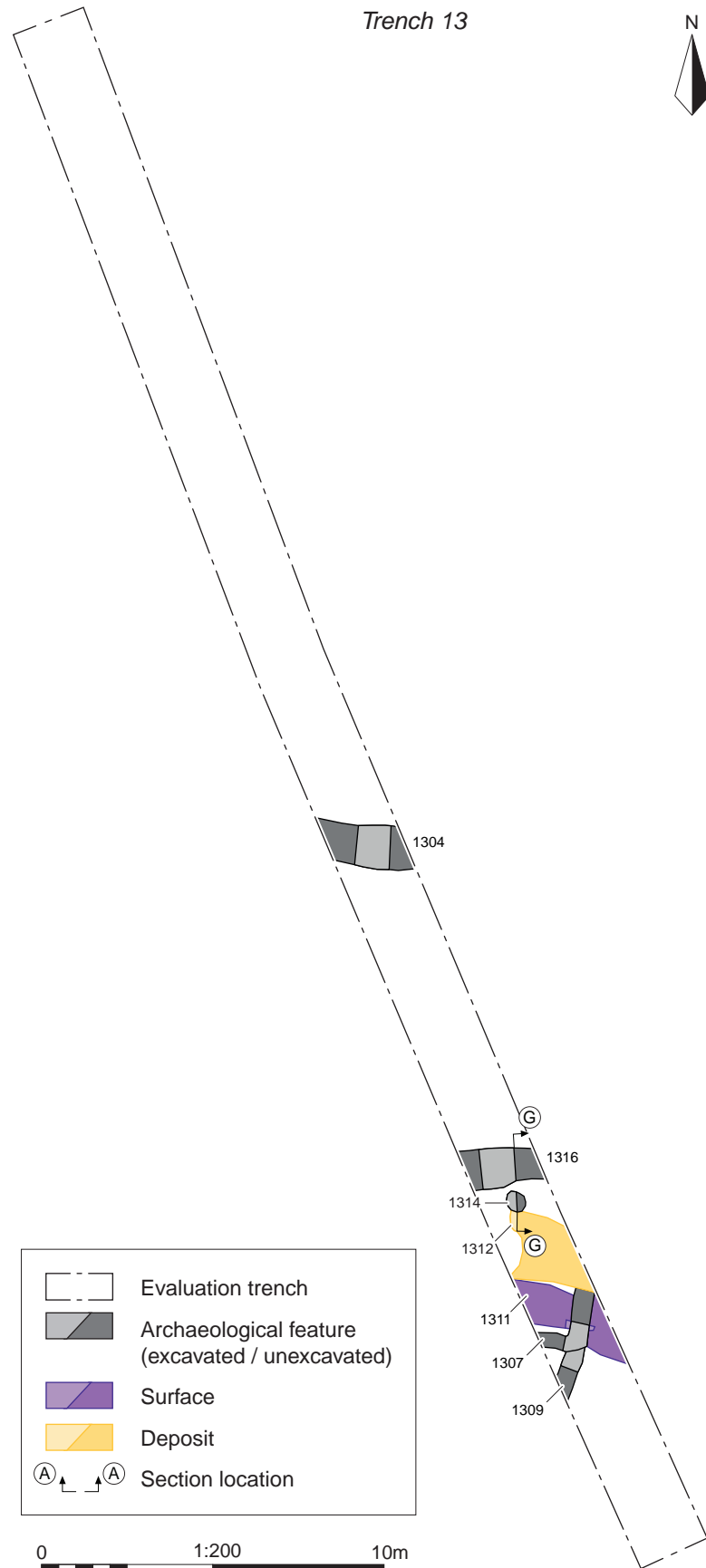

- Evaluation trench
- Archaeological feature (excavated / unexcavated)
- Surface
- Deposit
- Section location

Andover 01264 347630
 Cirencester 01285 771022
 Milton Keynes 01908 564660
 Suffolk 01449 900120
 www.cotswoldarchaeology.co.uk
 enquiries@cotswoldarchaeology.co.uk

PROJECT TITLE
 Mallard Pass Solar Farm DCO,
 Essendine, Rutland & Lincolnshire

FIGURE TITLE
 Area M6 (Rutland), Trench 13a: plan,
 section and photographs



Possible surface 1311 and ditch 1307 / 1309 (foreground), looking north (1m scale)



Andover 01264 347630
Cirencester 01285 771022
Milton Keynes 01908 564660
Suffolk 01449 900120
www.cotswoldarchaeology.co.uk
enquiries@cotswoldarchaeology.co.uk

PROJECT TITLE

Mallard Pass Solar Farm DCO,
Essendine, Rutland & Lincolnshire

FIGURE TITLE

Area M6 (Rutland), Trench 13:
photograph

DRAWN BY RW PROJECT NO. MK0789
CHECKED BY DJB DATE 07/02/2023
APPROVED BY AW SCALE@A4 NA

FIGURE NO.

33

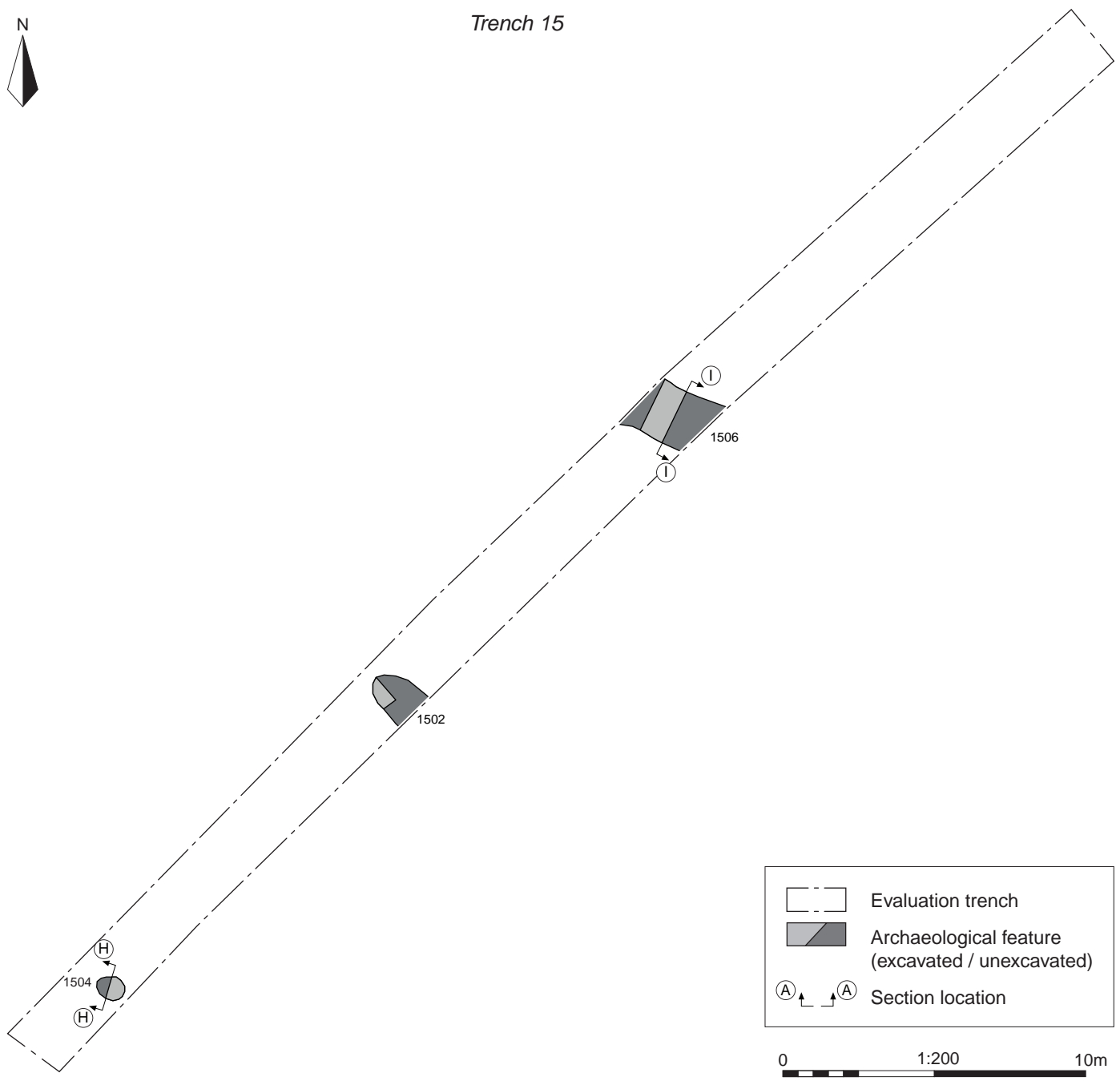
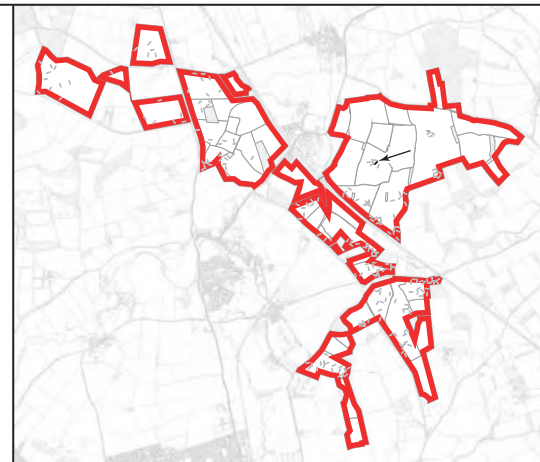

Trench 15, looking south-west (1m scales)

Cotswold Archaeology
 Andover 01264 347630
 Cirencester 01285 771022
 Milton Keynes 01908 564660
 Suffolk 01449 900120
www.cotswoldarchaeology.co.uk
enquiries@cotswoldarchaeology.co.uk

PROJECT TITLE
 Mallard Pass Solar Farm DCO,
 Essendine, Rutland & Lincolnshire

FIGURE TITLE
 Area M6 (Rutland), Trench 15: plan and photograph

DRAWN BY RW	PROJECT NO. MK0789	FIGURE NO.
CHECKED BY DJB	DATE 07/02/2023	34
APPROVED BY AW	SCALE@A3 1:200	

Section HH

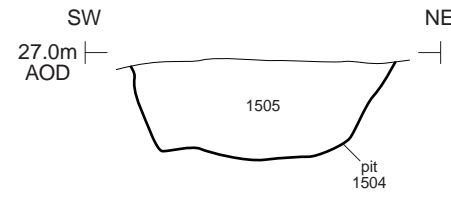

Section II

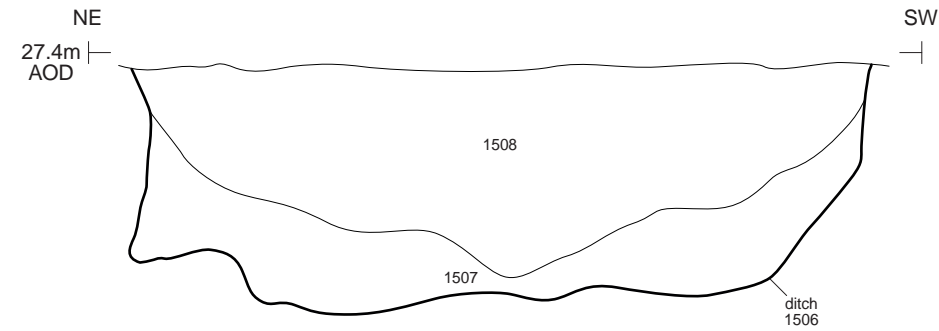

Pit 1504, looking north-west (0.4m scale)



Ditch 1506, looking south-east (1m scale)



Cotswold Archaeology
 Andover 01264 347630
 Cirencester 01285 771022
 Milton Keynes 01908 564660
 Suffolk 01449 900120
 www.cotswoldarchaeology.co.uk
 enquiries@cotswoldarchaeology.co.uk

PROJECT TITLE
**Mallard Pass Solar Farm DCO,
 Essendine, Rutland & Lincolnshire**

FIGURE TITLE
**Area M6 (Rutland), Trench 15: sections
 and photographs**

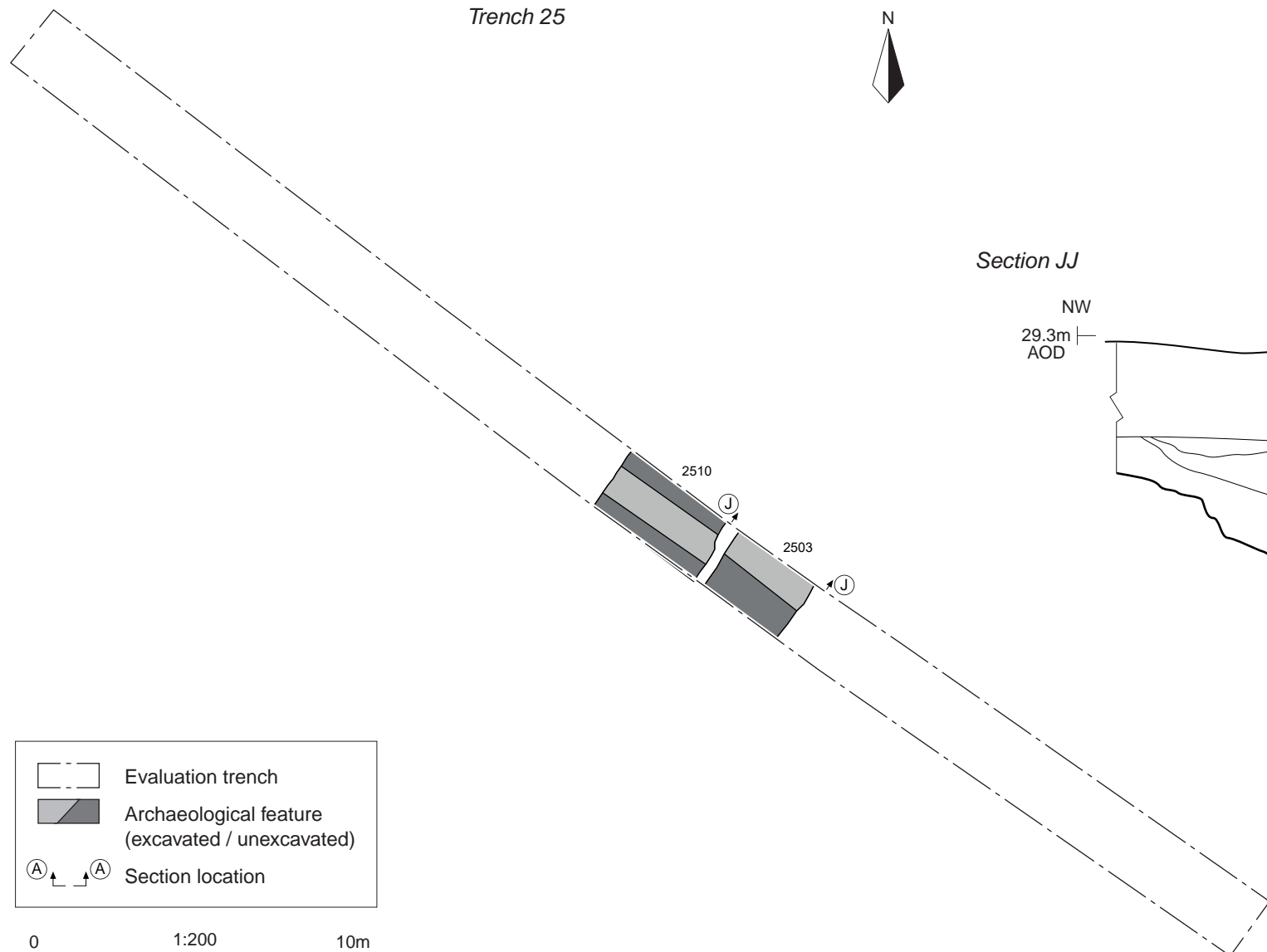

DRAWN BY	RW	PROJECT NO.	MK0789	FIGURE NO.
CHECKED BY	DJB	DATE	07/02/2023	35
APPROVED BY	AW	SCALE@A3	1:20	

Trench 25

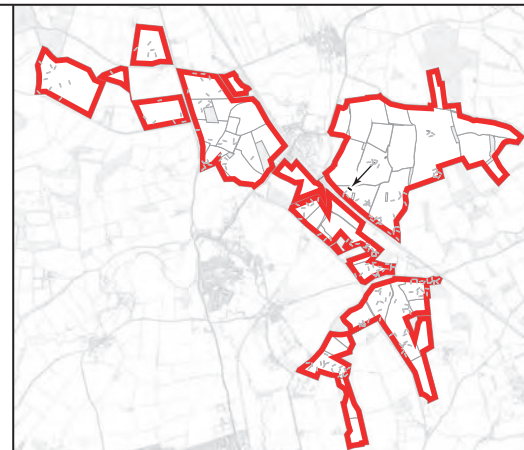
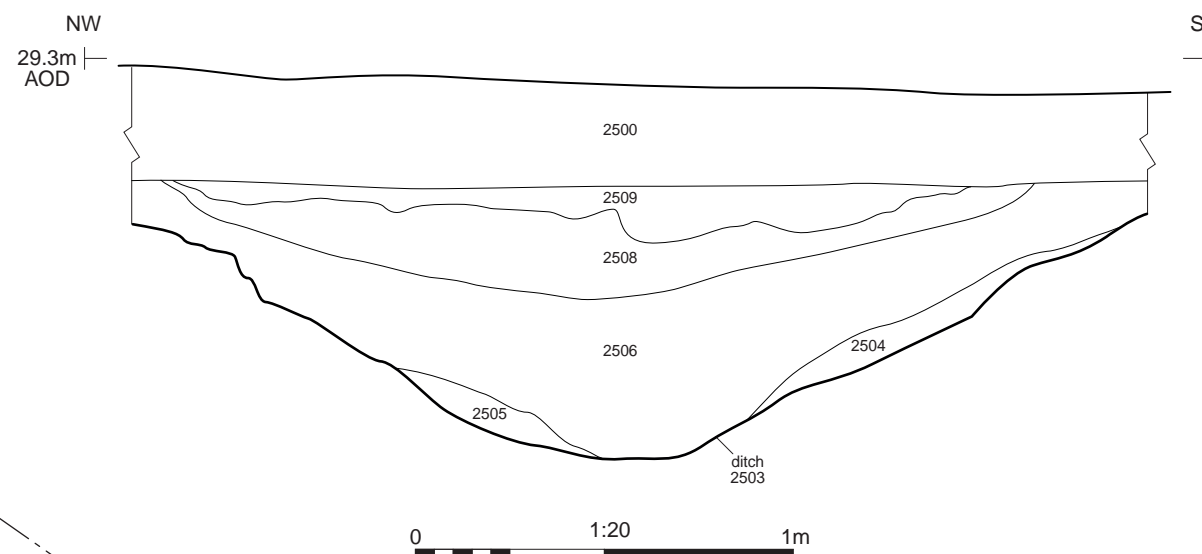

Section JJ



 Evaluation trench
 Archaeological feature (excavated / unexcavated)
 Section location



Trench 25, looking south-east (1m scales)

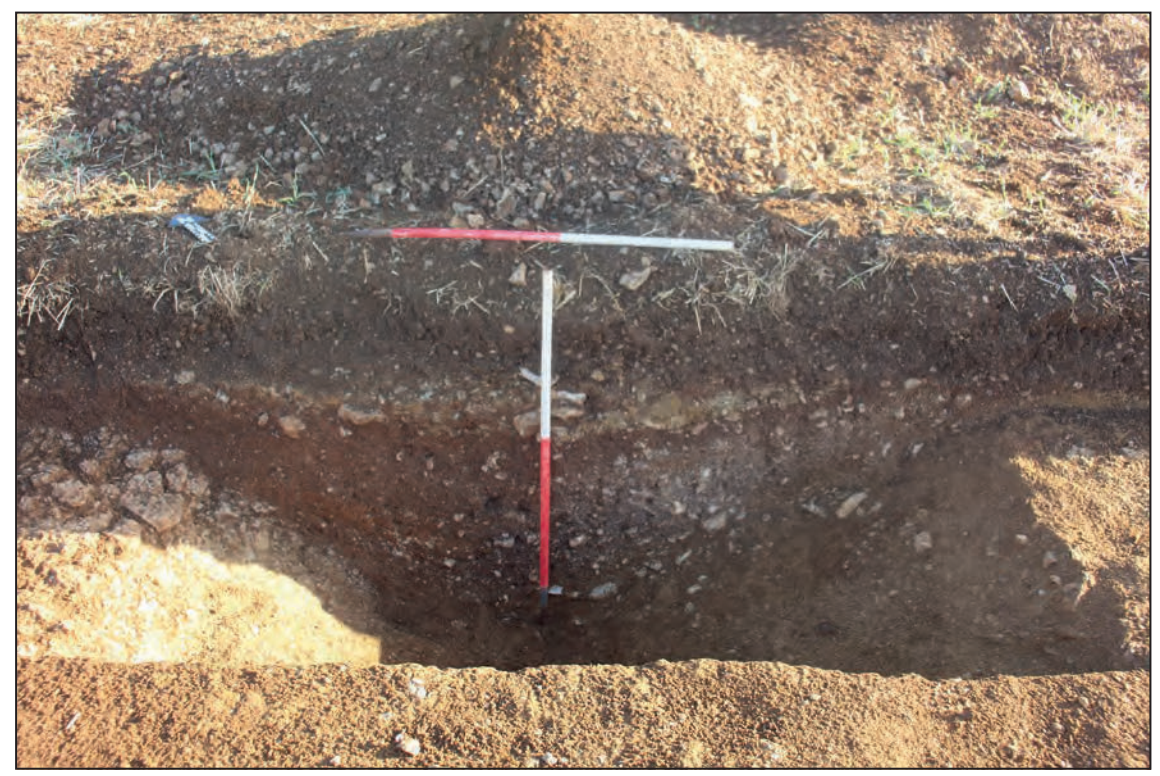

Ditch 2503, looking north-east (1m scales)

 Andover 01264 347630
 Cirencester 01285 771022
 Milton Keynes 01908 564660
 Suffolk 01449 900120
 www.cotswoldarchaeology.co.uk
 enquiries@cotswoldarchaeology.co.uk

PROJECT TITLE
Mallard Pass Solar Farm DCO,
Essendine, Rutland & Lincolnshire

FIGURE TITLE
**Area M7 (Rutland), Trench 25: plan,
section and photographs**

DRAWN BY	RW	PROJECT NO.	MK0789	FIGURE NO.
CHECKED BY	DJB	DATE	07/02/2023	36
APPROVED BY	AW	SCALE@A3	1:200, 1:20	



Trench 27

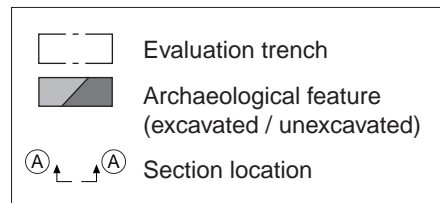
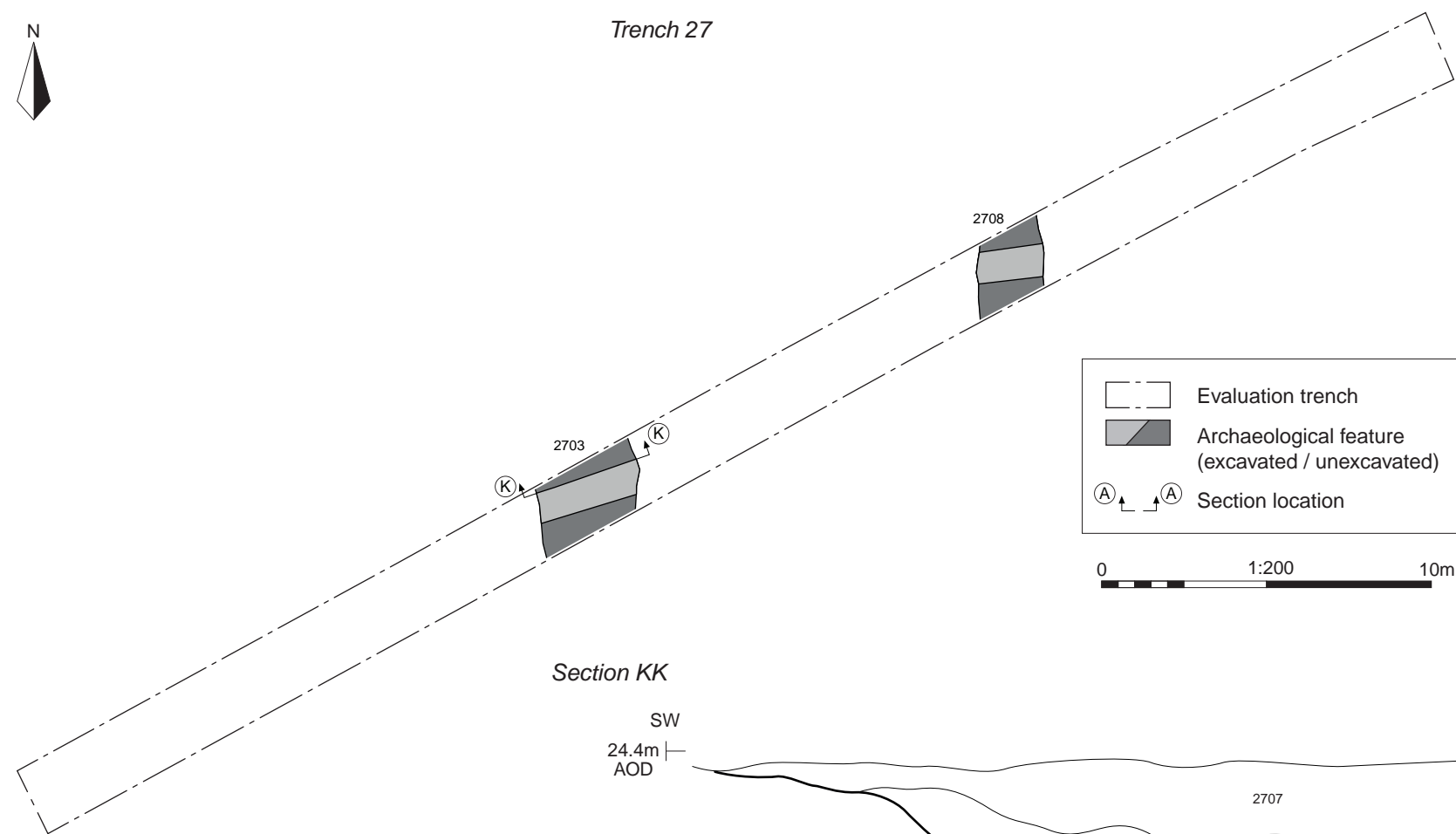

0 1:200 10m

Section KK

SW
24.4m
AOD

NE

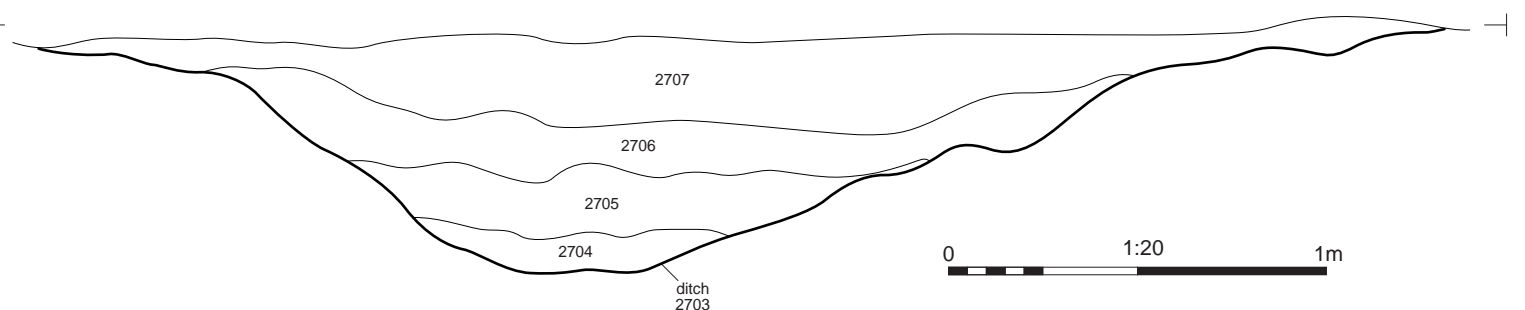

0 1:20 1m

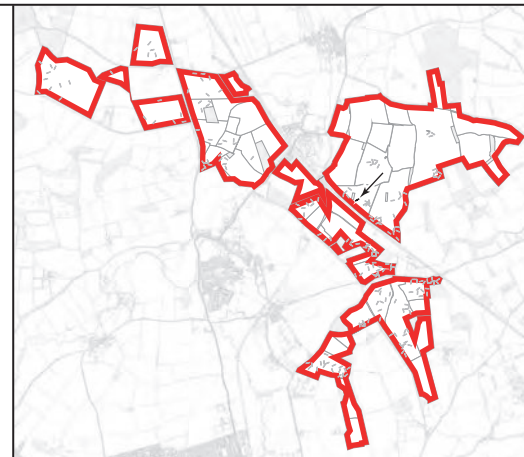

Trench 27, looking south-west (1m scales)



Ditch 2703, looking north (1m scale)

Cotswold Archaeology
 Andover 01264 347630
 Cirencester 01285 771022
 Milton Keynes 01908 564660
 Suffolk 01449 900120
 www.cotswoldarchaeology.co.uk
 enquiries@cotswoldarchaeology.co.uk

PROJECT TITLE
**Mallard Pass Solar Farm DCO,
 Essendine, Rutland & Lincolnshire**

FIGURE TITLE
**Area M7 (Rutland), Trench 27: plan,
 section and photographs**

DRAWN BY	RW	PROJECT NO.	MK0789	FIGURE NO.
CHECKED BY	DJB	DATE	07/02/2023	37
APPROVED BY	AW	SCALE@A3	1:200, 1:20	

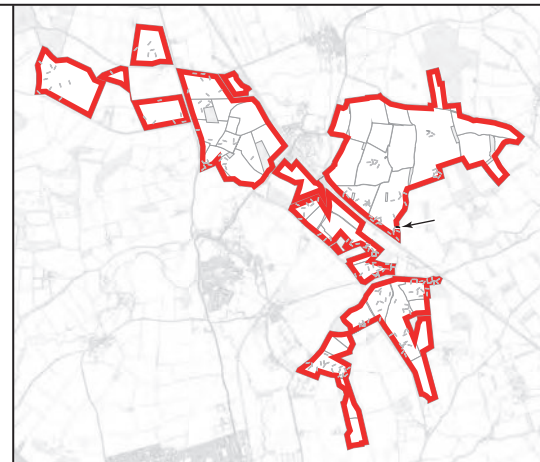
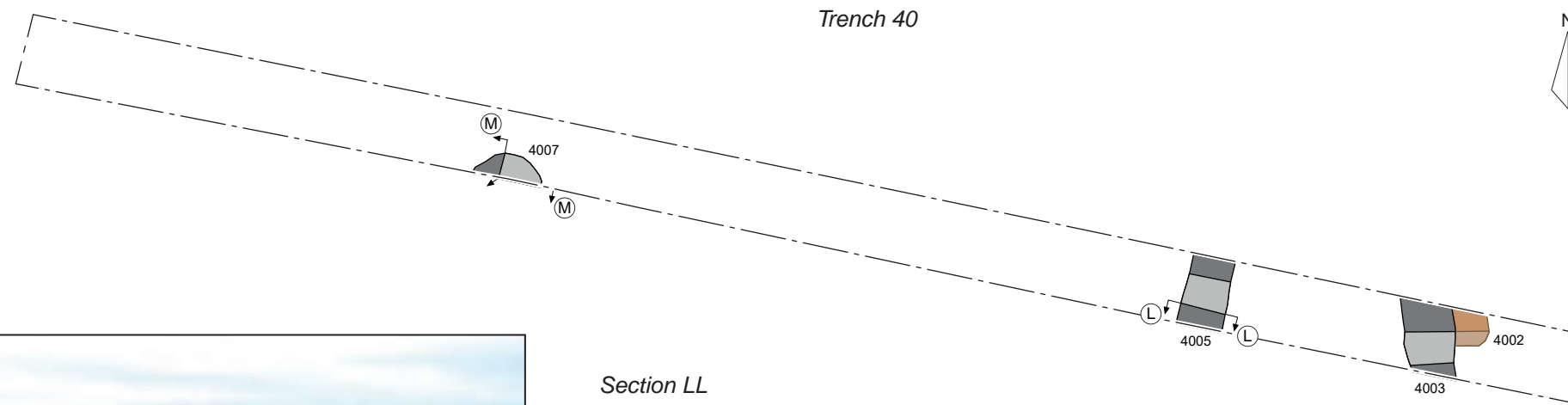
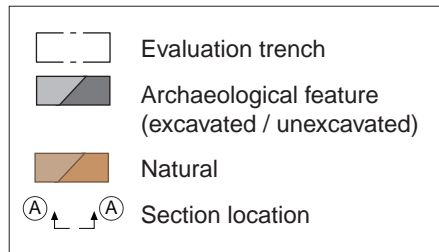

Trench 40, looking south-east (1m scales)

Section LL

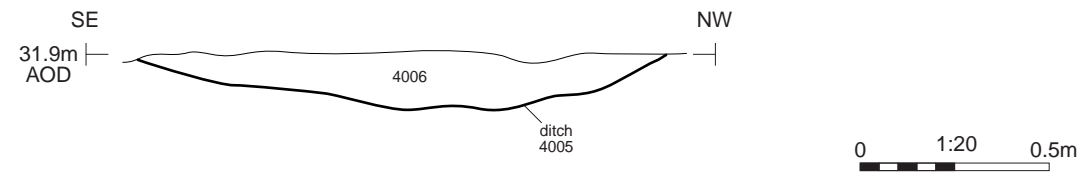

Section MM

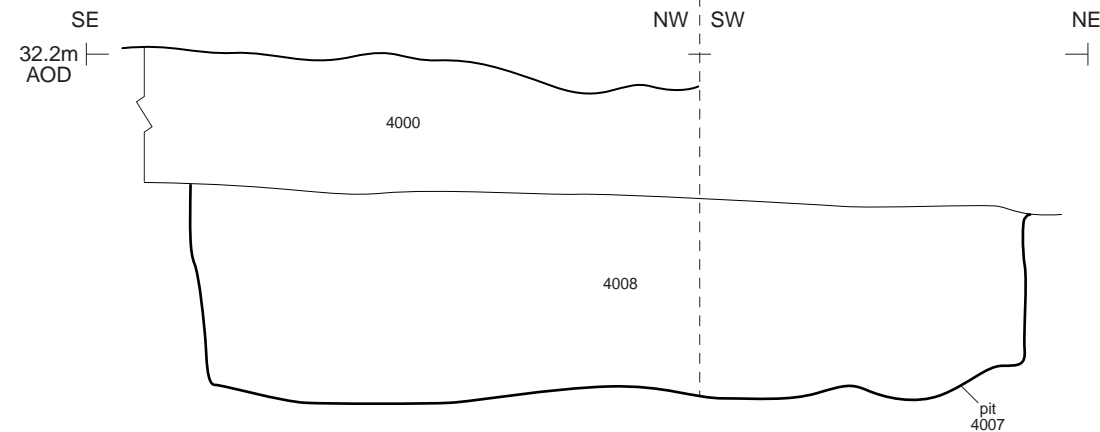

Ditch 4005, looking south-west (1m scale)



Pit 4007, looking south-west (1m scale)

Andover 01264 347630
 Cirencester 01285 771022
 Milton Keynes 01908 564660
 Suffolk 01449 900120
 www.cotswoldarchaeology.co.uk
 enquiries@cotswoldarchaeology.co.uk

PROJECT TITLE
 Mallard Pass Solar Farm DCO,
 Essendine, Rutland & Lincolnshire

FIGURE TITLE
 Area M10 (Rutland), Trench 40: plan,
 section and photographs

DRAWN BY RW PROJECT NO. MK0789 FIGURE NO.
 CHECKED BY DJB DATE 07/02/2023
 APPROVED BY AW SCALE@A3 1:200, 1:20 38

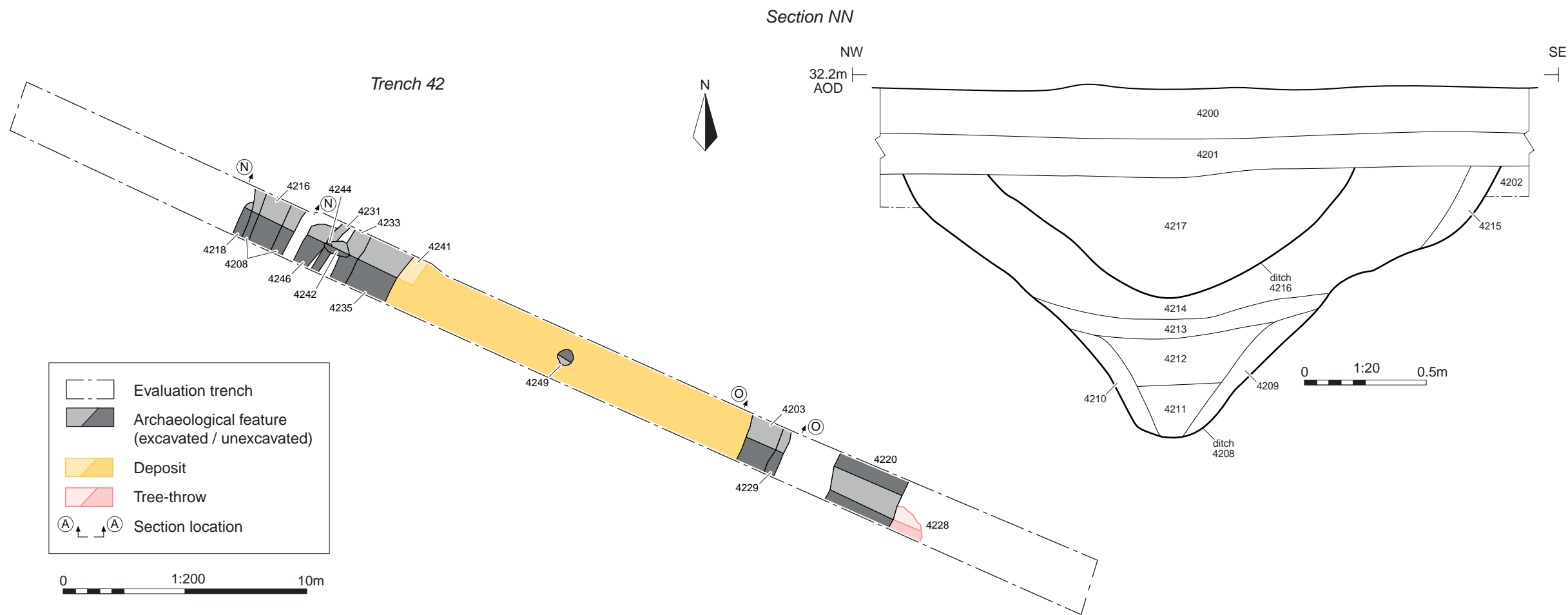

Trench 42, looking north-west (1m scales)



Ditch 4208, looking north-east (1m scale)



Cotswold Archaeology
 Andover 01264 347630
 Cirencester 01285 771022
 Milton Keynes 01908 564660
 Suffolk 01449 900120
www.cotswoldarchaeology.co.uk
enquiries@cotswoldarchaeology.co.uk

PROJECT TITLE
Mallard Pass Solar Farm DCO,
 Essendine, Rutland & Lincolnshire

FIGURE TITLE
Area M10 (Rutland), Trench 42: plan,
section and photographs

DRAWN BY	RW	PROJECT NO.	MK0789	FIGURE NO.
CHECKED BY	DJB	DATE	07/02/2023	39
APPROVED BY	AW	SCALE@A3	1:200, 1:20	

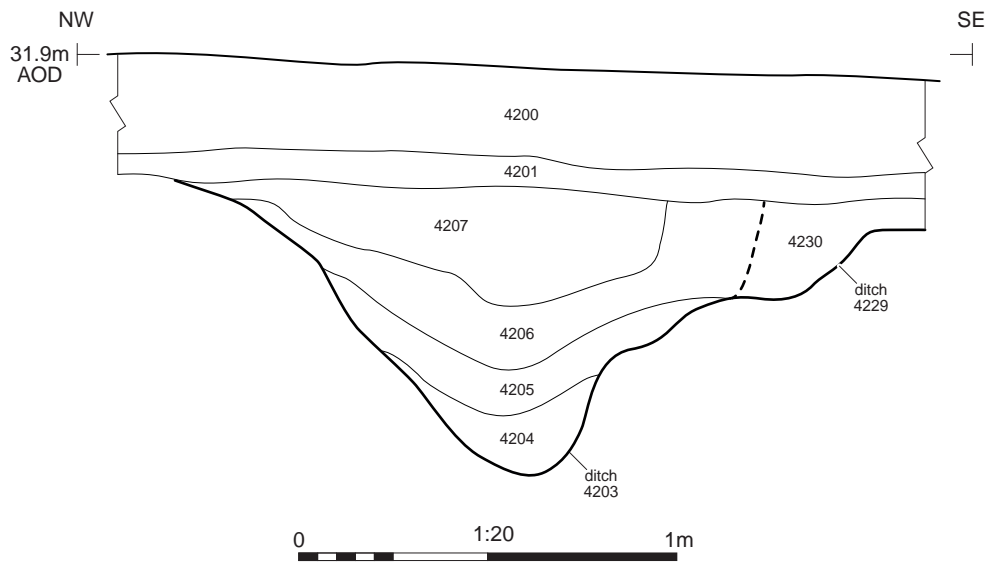
Section OO



Ditches 4203 (centre) and 4229 (far-right), looking north-east (1m scale)



Andover 01264 347630
 Cirencester 01285 771022
 Milton Keynes 01908 564660
 Suffolk 01449 900120
www.cotswoldarchaeology.co.uk
enquiries@cotswoldarchaeology.co.uk

PROJECT TITLE

Mallard Pass Solar Farm DCO,
 Essendine, Rutland & Lincolnshire

FIGURE TITLE

**Area M10 (Rutland), Trench 42: section
 and photograph**

DRAWN BY RW PROJECT NO. MK0789
 CHECKED BY DJB DATE 07/02/2023
 APPROVED BY AW SCALE@A4 1:20

FIGURE NO.

40



Trench 44, looking south-east (1m scales)



Pit 4407, looking north-east (0.5m scale)



Pit 4411, looking south-east (0.5m scale)

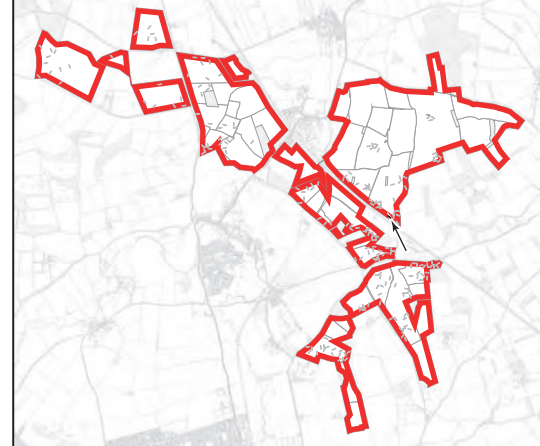
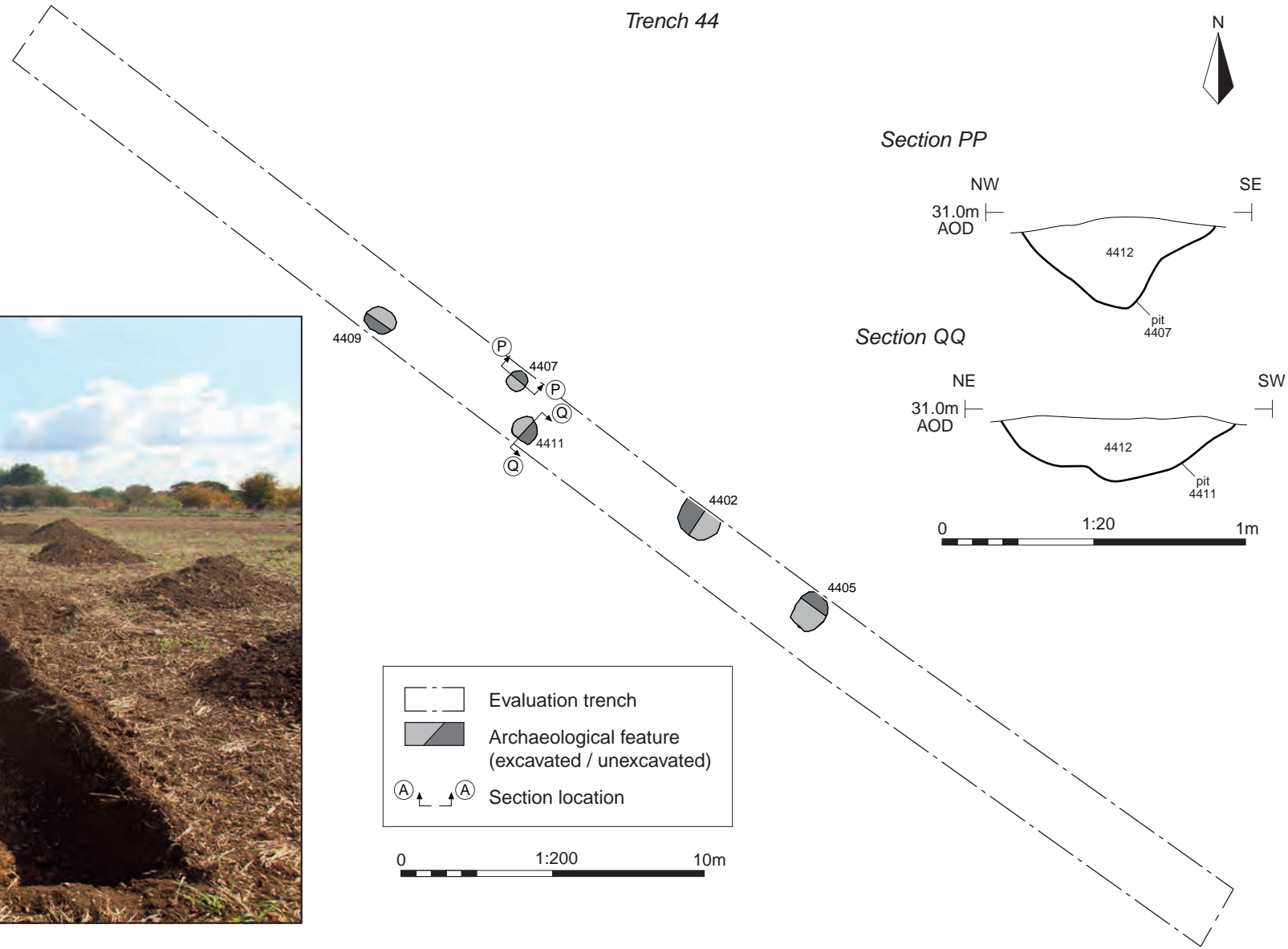

Andover 01264 347630
 Cirencester 01285 771022
 Milton Keynes 01908 564660
 Suffolk 01449 900120
 www.cotswoldarchaeology.co.uk
 enquiries@cotswoldarchaeology.co.uk

PROJECT TITLE
 Mallard Pass Solar Farm DCO,
 Essendine, Rutland & Lincolnshire

FIGURE TITLE
 Area M10 (Rutland), Trench 44: plan,
 sections and photographs

DRAWN BY	RW	PROJECT NO.	MK0789	FIGURE NO.
CHECKED BY	DJB	DATE	07/02/2023	41
APPROVED BY	AW	SCALE@A3	1:200, 1:20	

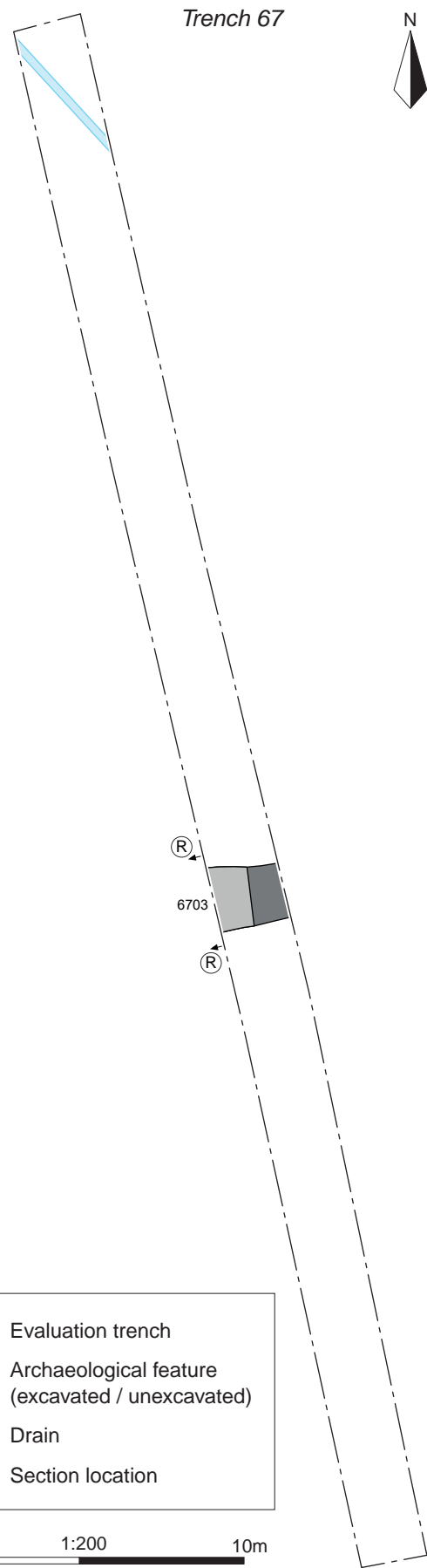

Section RR

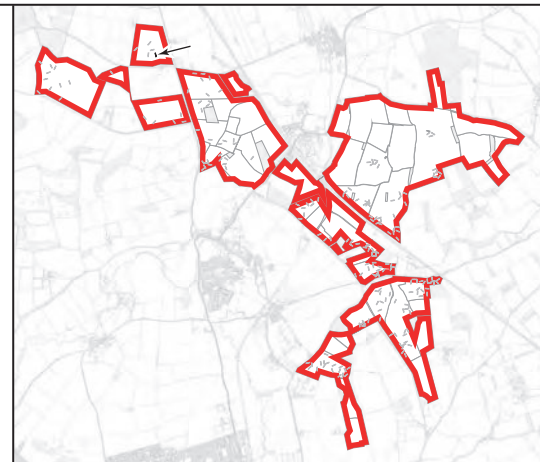
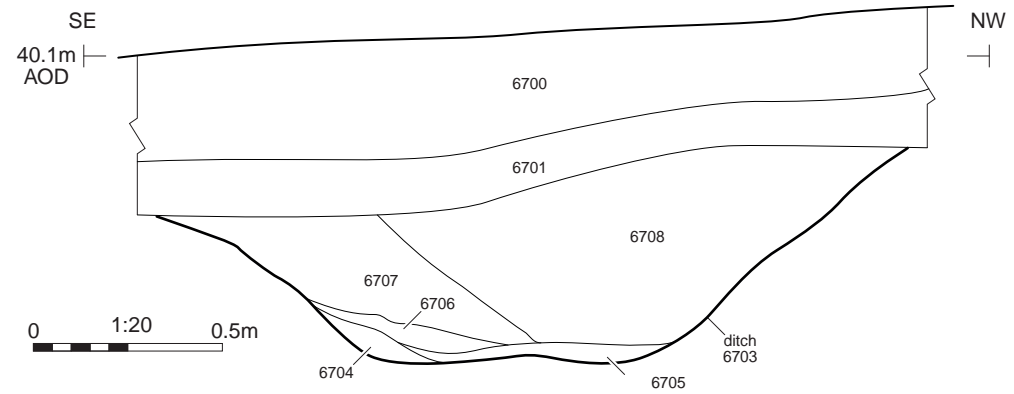

Trench 67, looking north-west (1m scales)



Ditch 6703, looking west (1m scale)

Cotswold Archaeology
 Andover 01264 347630
 Cirencester 01285 771022
 Milton Keynes 01908 564660
 Suffolk 01449 900120
 www.cotswoldarchaeology.co.uk
 enquiries@cotswoldarchaeology.co.uk

PROJECT TITLE
Mallard Pass Solar Farm DCO,
Essendine, Rutland & Lincolnshire

FIGURE TITLE
Area P1 (Rutland), Trench 67: plan,
section and photographs

DRAWN BY	RW	PROJECT NO.	MK0789	FIGURE NO.
CHECKED BY	DJB	DATE	07/02/2023	42
APPROVED BY	AW	SCALE@A3	1:200, 1:20	

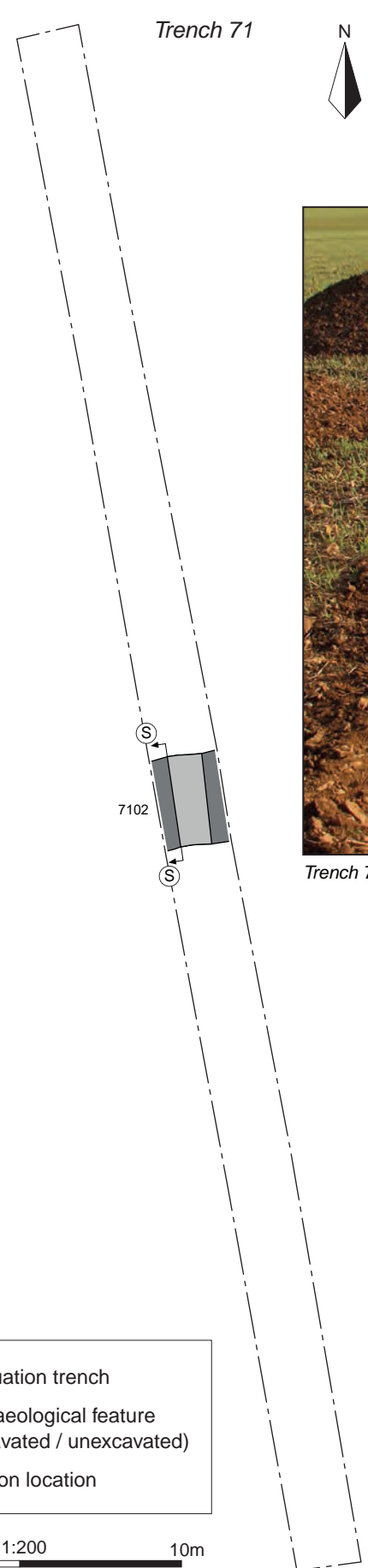

Trench 71, looking south-east (1m scales)

Section SS

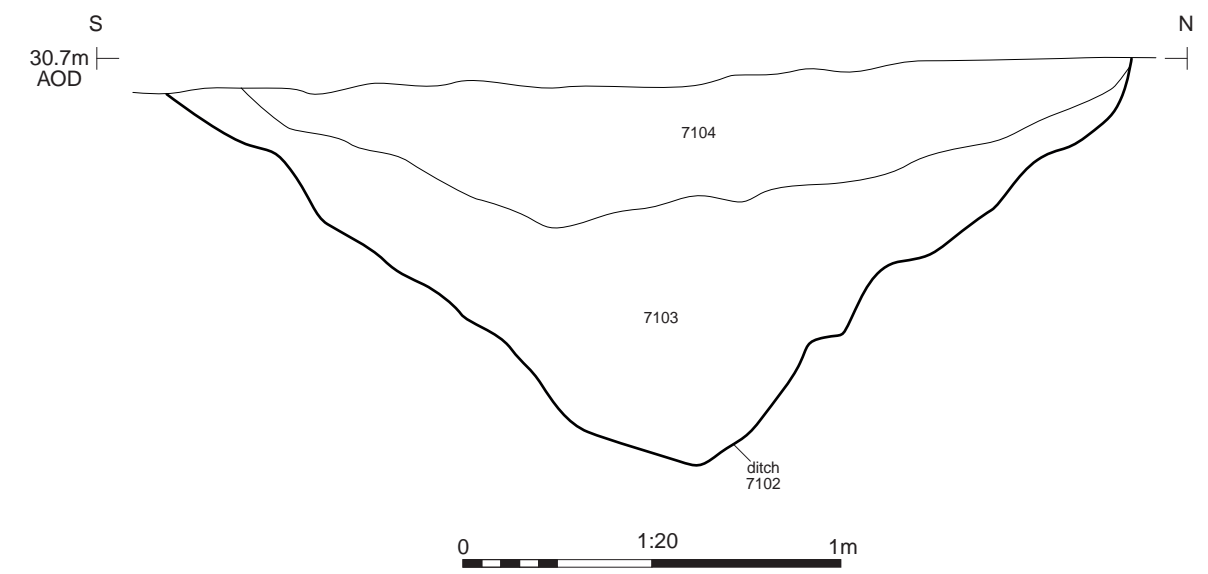

Ditch 7102, looking west (1m scales)

Evaluation trench
 Archaeological feature (excavated / unexcavated)
 Section location

Cotswold Archaeology
 Andover 01264 347630
 Cirencester 01285 771022
 Milton Keynes 01908 564660
 Suffolk 01449 900120
www.cotswoldarchaeology.co.uk
enquiries@cotswoldarchaeology.co.uk





PROJECT TITLE
 Mallard Pass Solar Farm DCO,
 Essendine, Rutland & Lincolnshire
FIGURE TITLE
 Area P2 (Rutland), Trench 71: plan,
 section and photographs

DRAWN BY	RW	PROJECT NO.	MK0789	FIGURE NO.
CHECKED BY	DJB	DATE	07/02/2023	43
APPROVED BY	AW	SCALE@A3	1:200, 1:20	

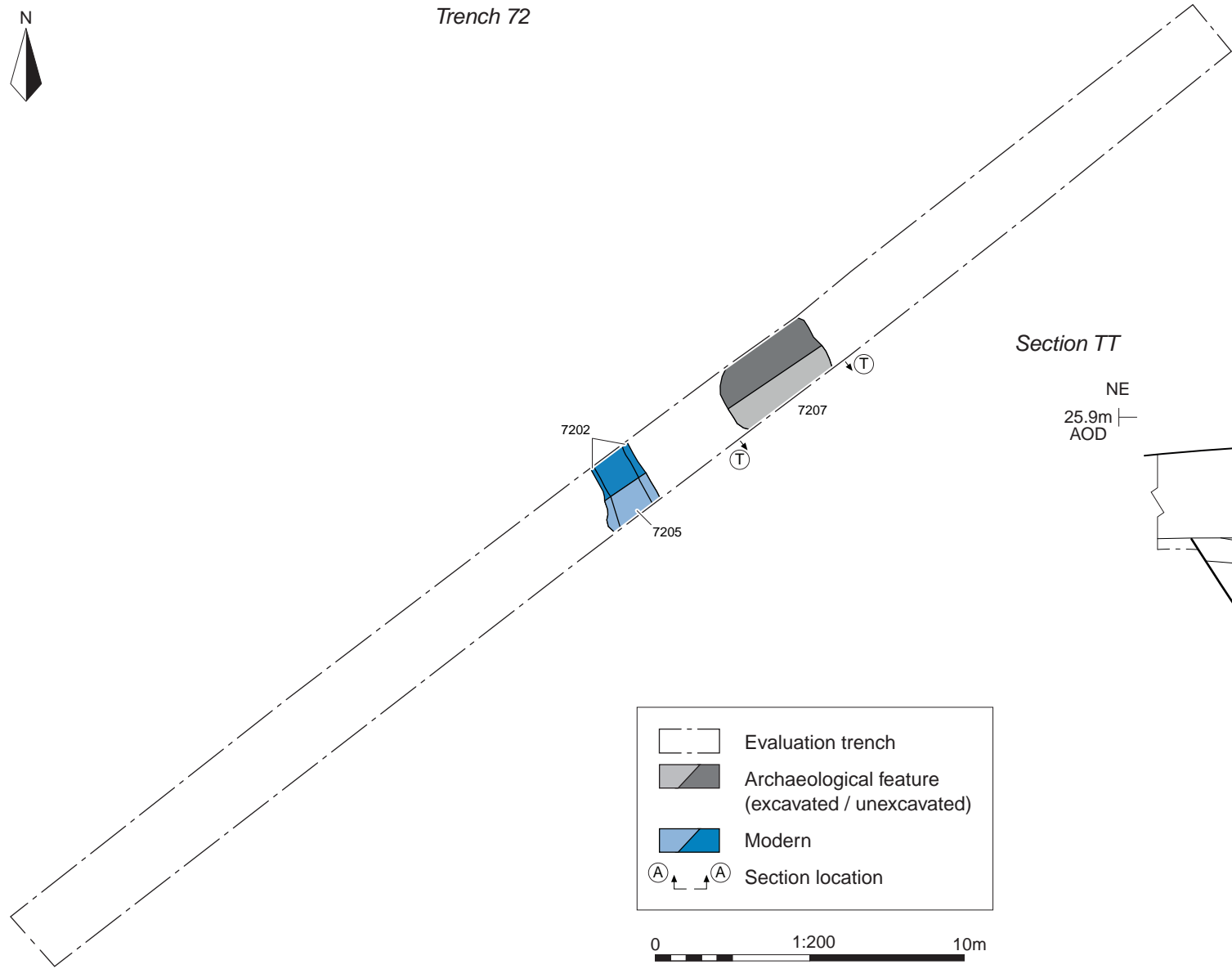

Trench 72



-  Evaluation trench
-  Archaeological feature (excavated / unexcavated)
-  Modern
-  Section location

0 1:200 10m

Section TT

NE
25.9m
AOD

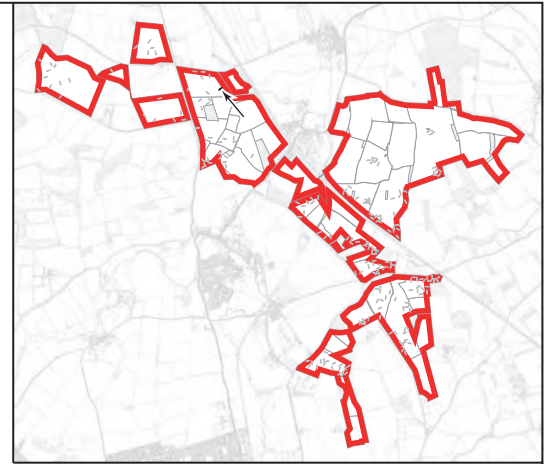
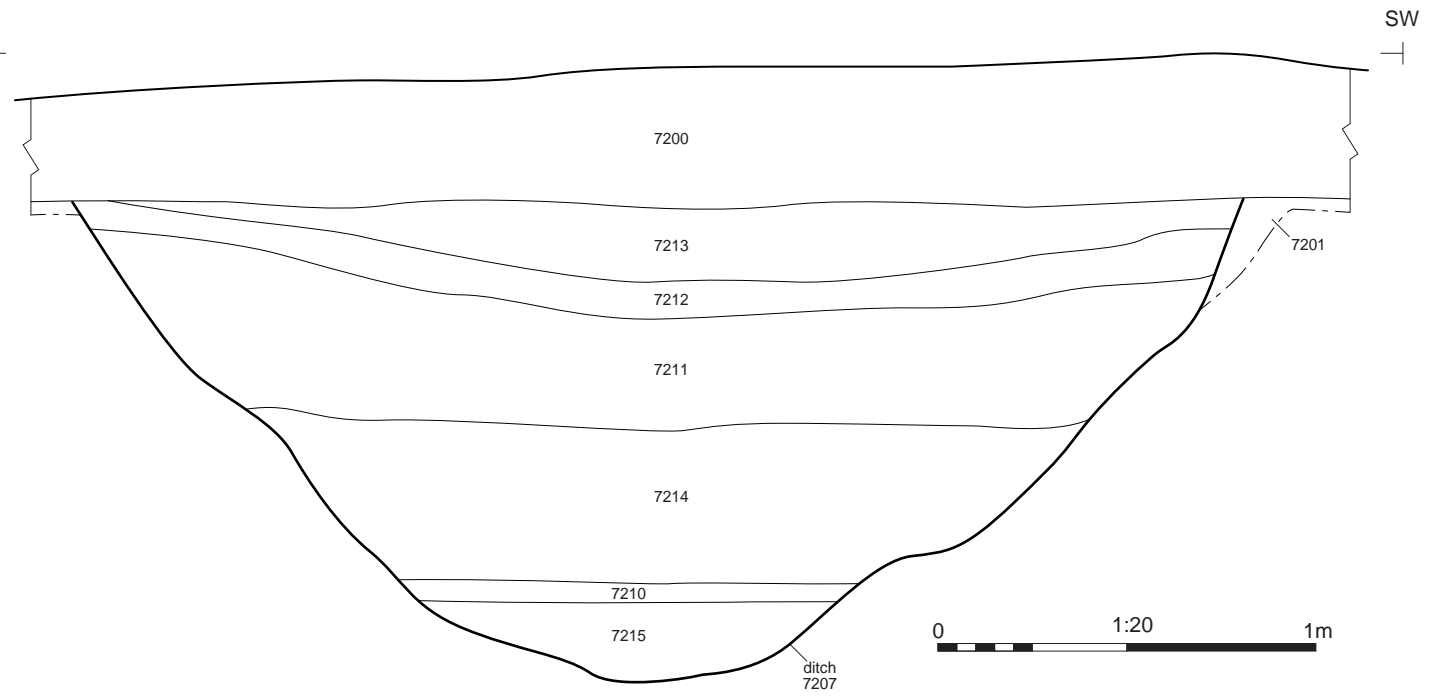

Trench 72, looking south-west (1m scales)



Ditch 7207, looking north-west (1m scale)

 Cotswold Archaeology
 Andover 01264 347630
 Cirencester 01285 771022
 Milton Keynes 01908 564660
 Suffolk 01449 900120
www.cotswoldarchaeology.co.uk
enquiries@cotswoldarchaeology.co.uk

PROJECT TITLE
Mallard Pass Solar Farm DCO,
Essendine, Rutland & Lincolnshire

FIGURE TITLE
Area P2 (Rutland), Trench 72: plan,
sections and photographs

DRAWN BY	RW	PROJECT NO.	MK0789	FIGURE NO.
CHECKED BY	DJB	DATE	07/02/2023	44
APPROVED BY	AW	SCALE@A3	1:200, 1:20	



Trench 86

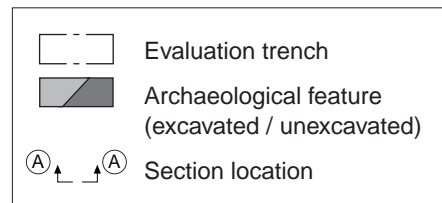
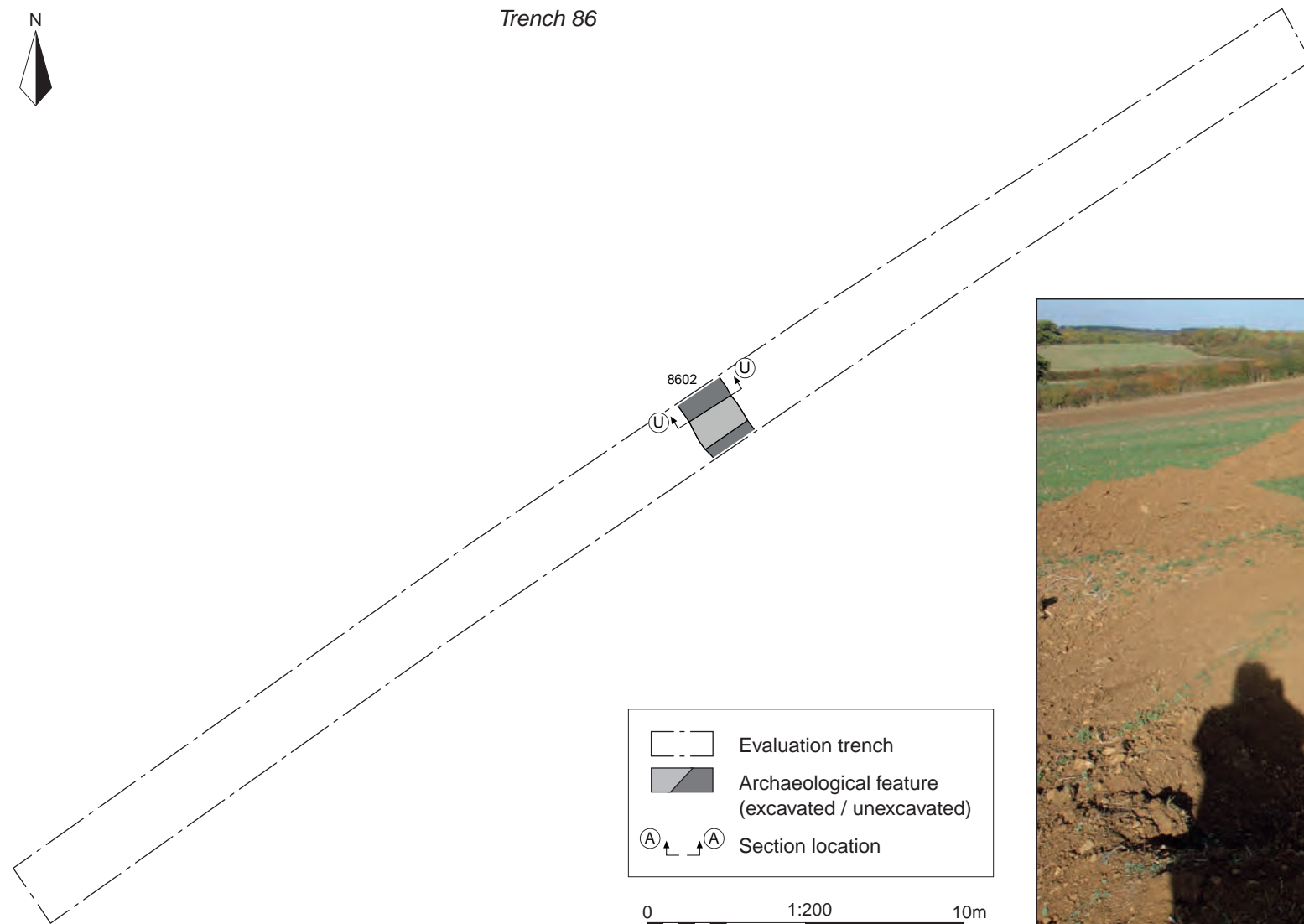

0 1:200 10m



Trench 86, looking north-east (1m scales)

Section UU



Ditch 8602, looking north-west (1m scale)

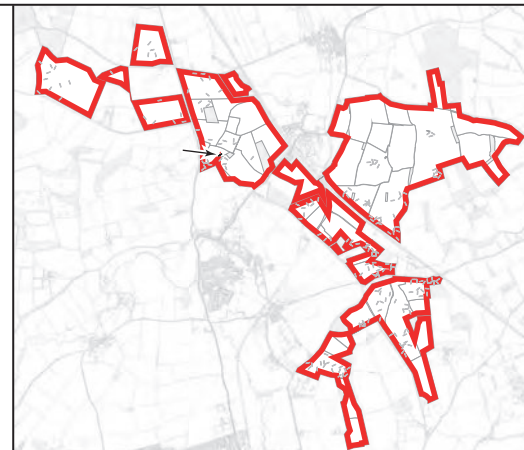



Cotswold Archaeology
 Andover 01264 347630
 Cirencester 01285 771022
 Milton Keynes 01908 564660
 Suffolk 01449 900120
www.cotswoldarchaeology.co.uk
enquiries@cotswoldarchaeology.co.uk

PROJECT TITLE
 Mallard Pass Solar Farm DCO,
 Essendine, Rutland & Lincolnshire

FIGURE TITLE
 Area P11 (Rutland), Trench 86: plan,
 section and photographs

DRAWN BY	RW	PROJECT NO.	MK0789	FIGURE NO.
CHECKED BY	DJB	DATE	07/02/2023	45
APPROVED BY	AW	SCALE@A3	1:200, 1:20	

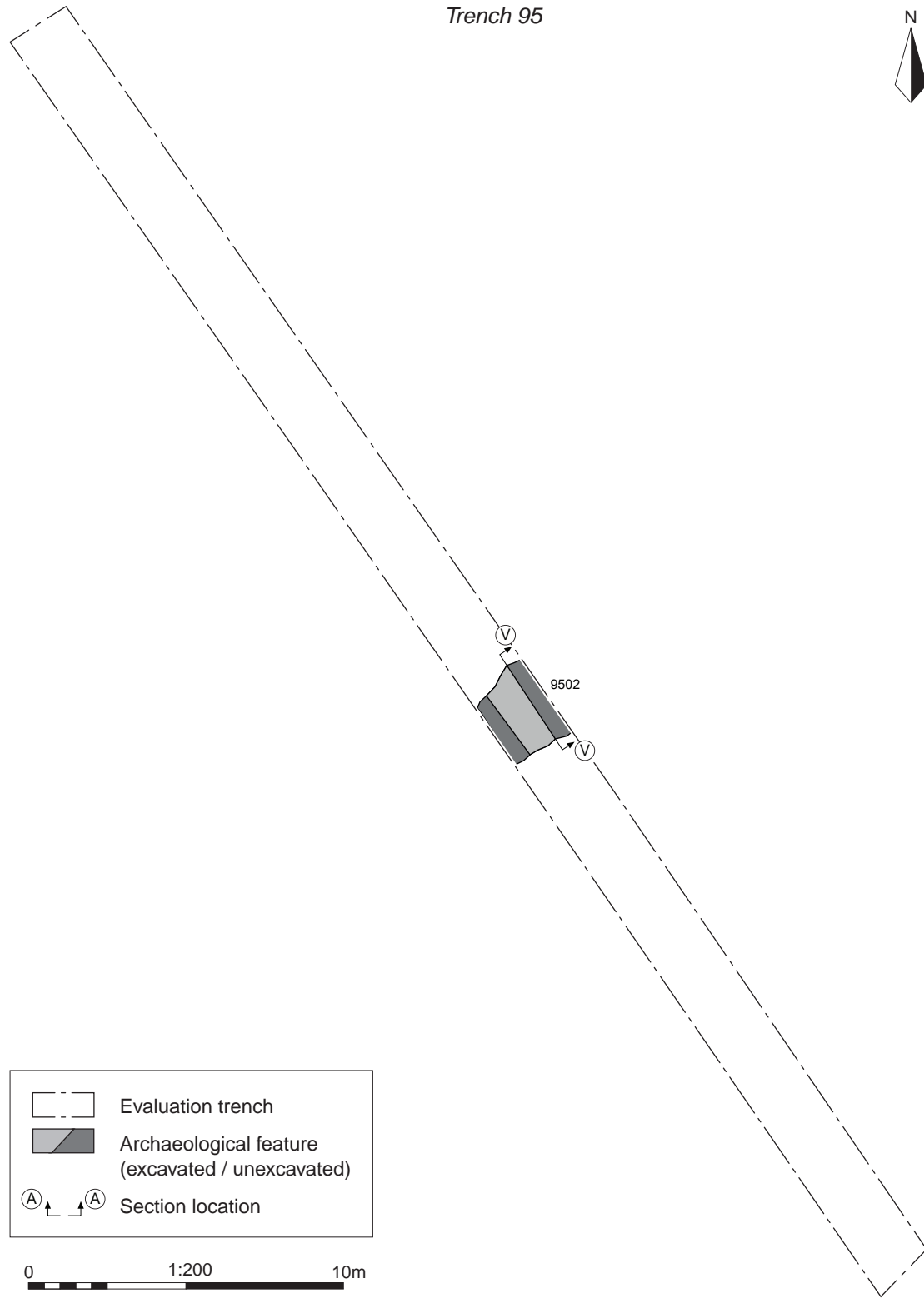
Trench 95



Trench 95, looking north-west (1m scales)



Ditch 9502, looking north-east (1m scale)

Section VV

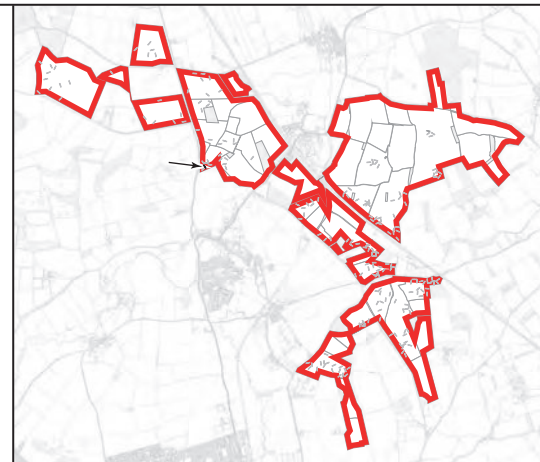
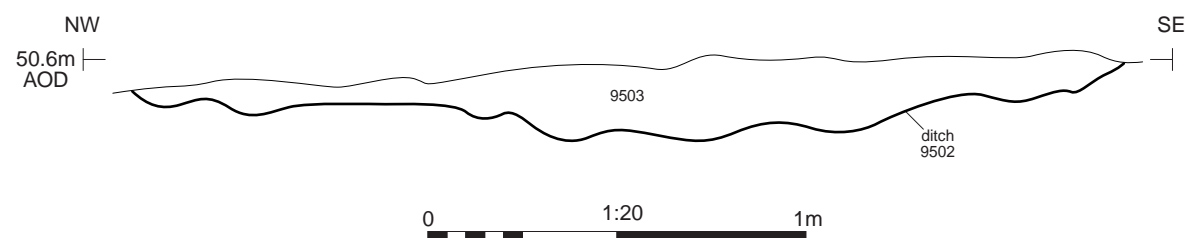

Andover 01264 347630
 Cirencester 01285 771022
 Milton Keynes 01908 564660
 Suffolk 01449 900120
www.cotswoldarchaeology.co.uk
enquiries@cotswoldarchaeology.co.uk

PROJECT TITLE
 Mallard Pass Solar Farm DCO,
 Essendine, Rutland & Lincolnshire

FIGURE TITLE
 Area P12 (Rutland), Trench 95: plan,
 section and photographs

DRAWN BY	RW	PROJECT NO.	MK0789	FIGURE NO.
CHECKED BY	DJB	DATE	07/02/2023	46
APPROVED BY	AW	SCALE@A3	1:200, 1:20	

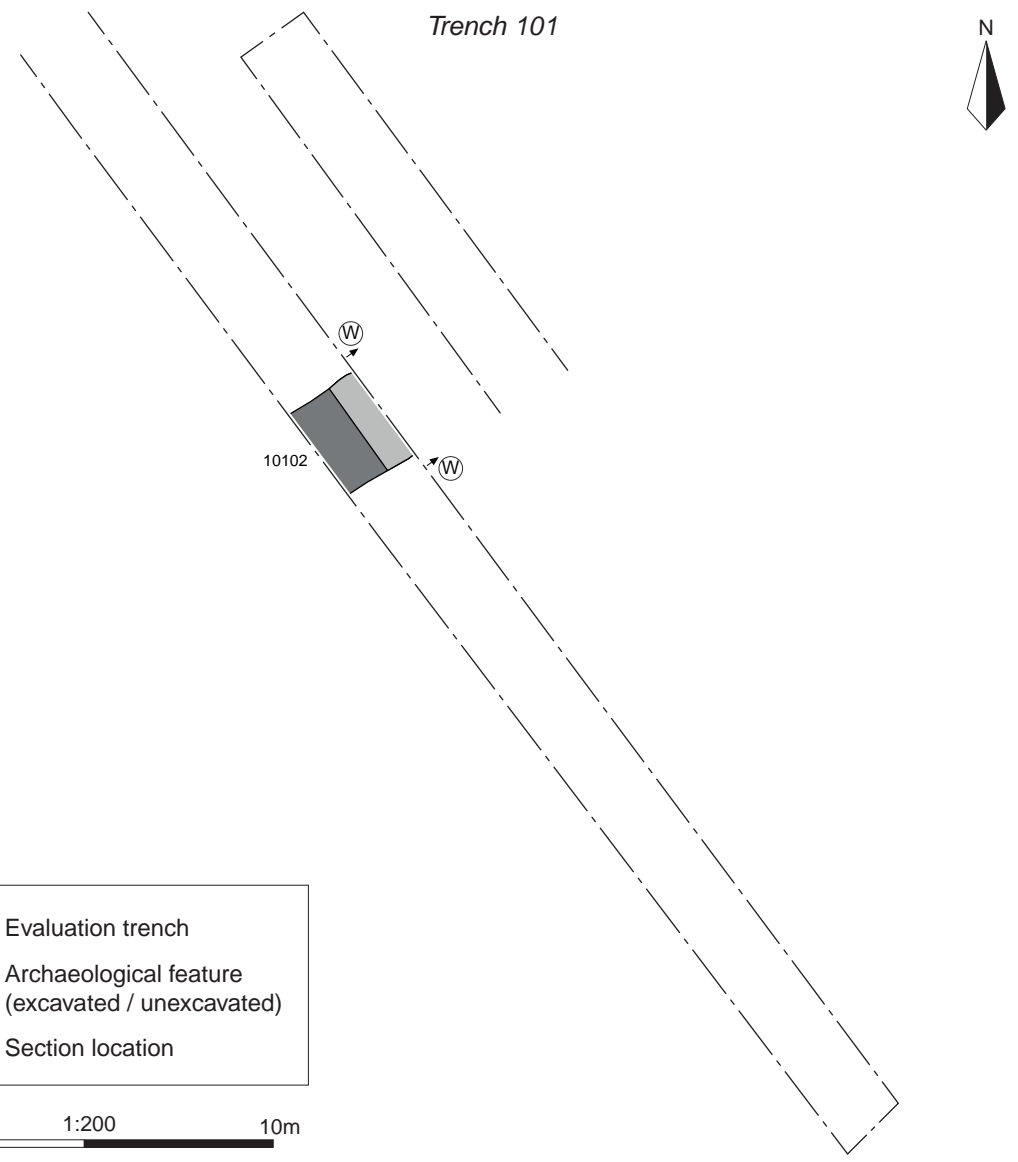

Evaluation trench
 Archaeological feature (excavated / unexcavated)
 Section location

0 1:200 10m

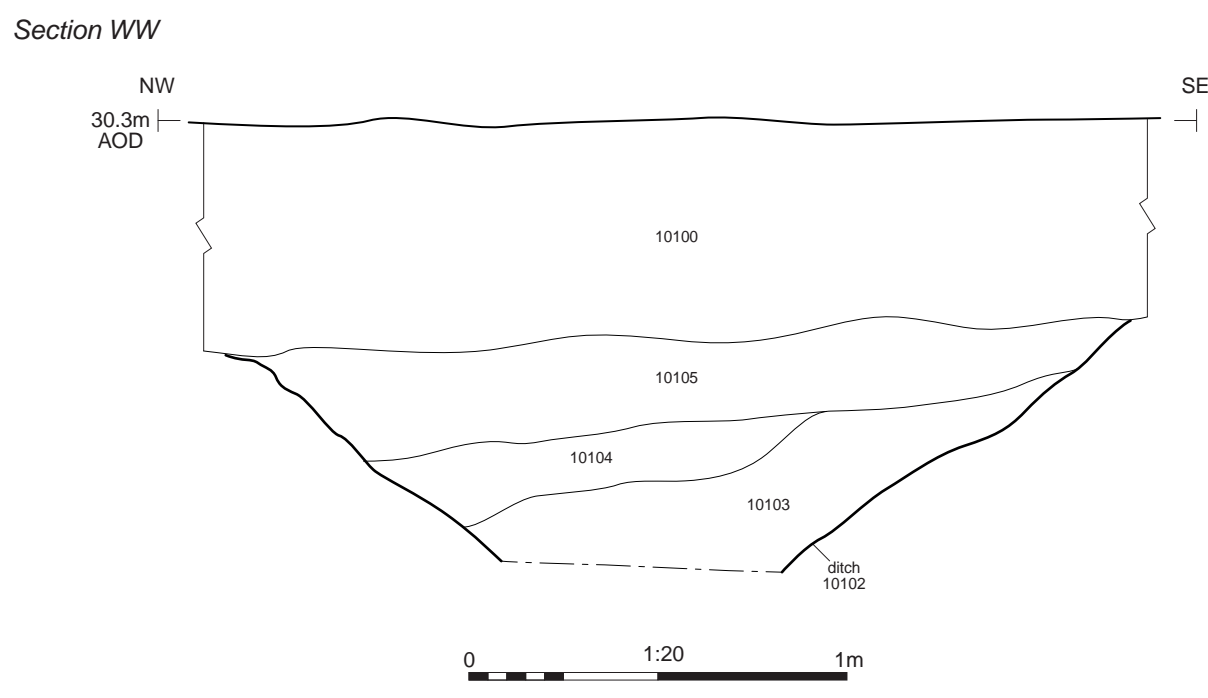

Trench 101, looking south-east (1m scales)



Ditch 10102, looking north-east (2m scale)

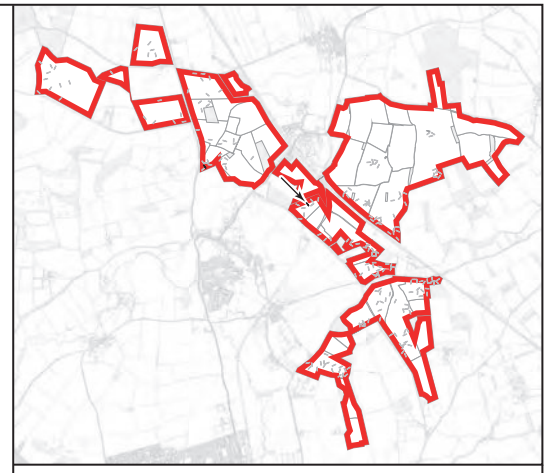

Cotswold Archaeology
 Andover 01264 347630
 Cirencester 01285 771022
 Milton Keynes 01908 564660
 Suffolk 01449 900120
 www.cotswoldarchaeology.co.uk
 enquiries@cotswoldarchaeology.co.uk

PROJECT TITLE
 Mallard Pass Solar Farm DCO,
 Essendine, Rutland & Lincolnshire

FIGURE TITLE
 Area PF1 (Rutland), Trench 101: plan,
 section and photographs

DRAWN BY	RW	PROJECT NO.	MK0789	FIGURE NO.
CHECKED BY	DJB	DATE	07/02/2023	47
APPROVED BY	AW	SCALE@A3	1:200, 1:20	



Trench 103

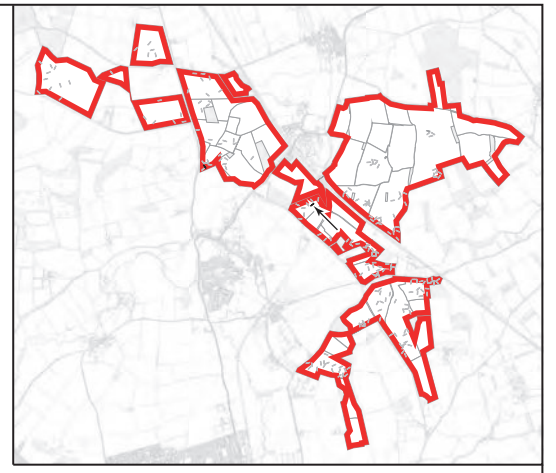
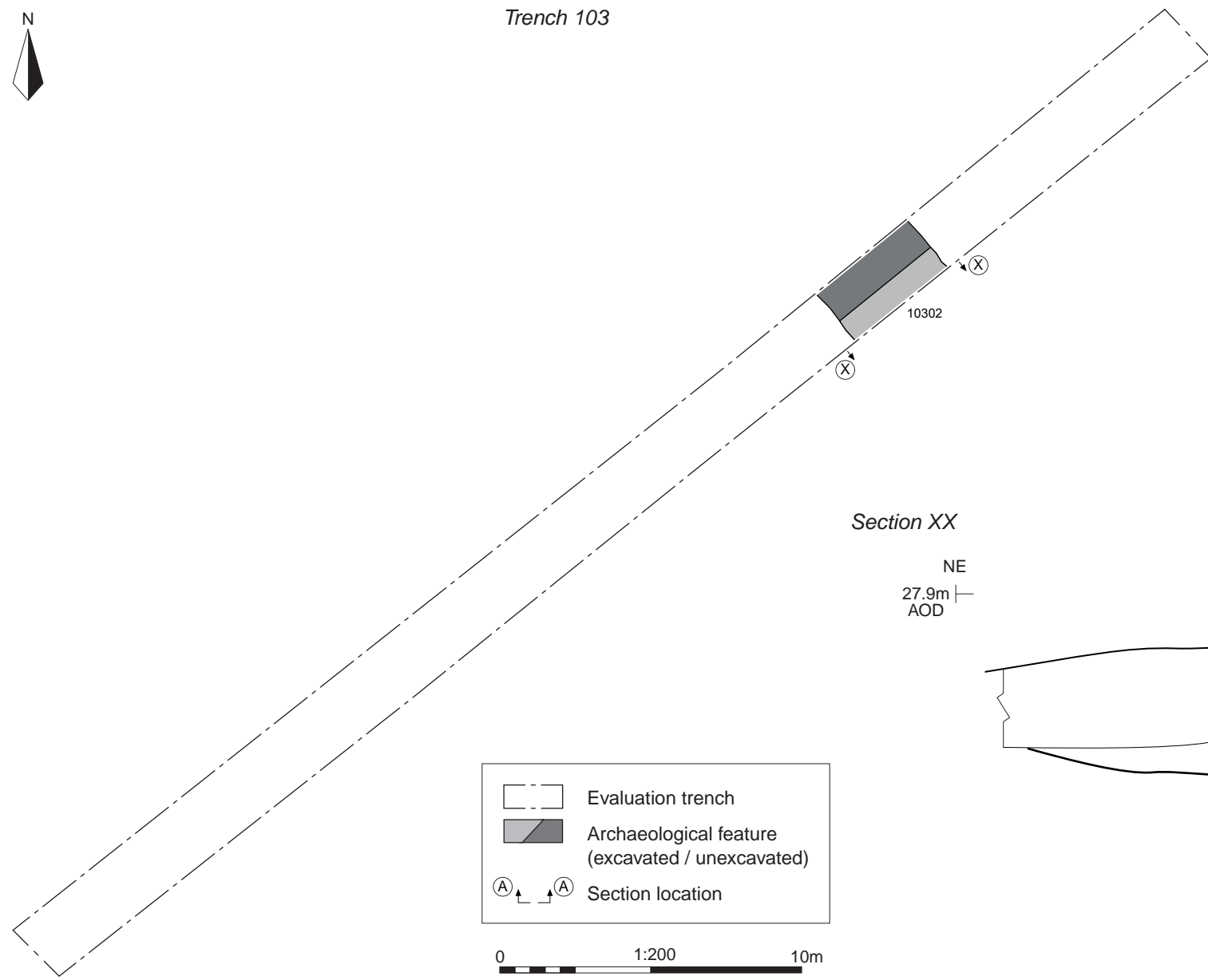

Section XX

NE
27.9m
AOD

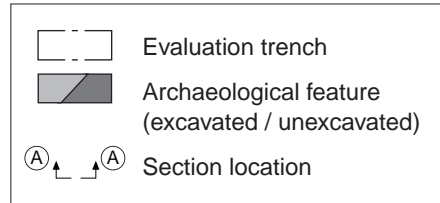
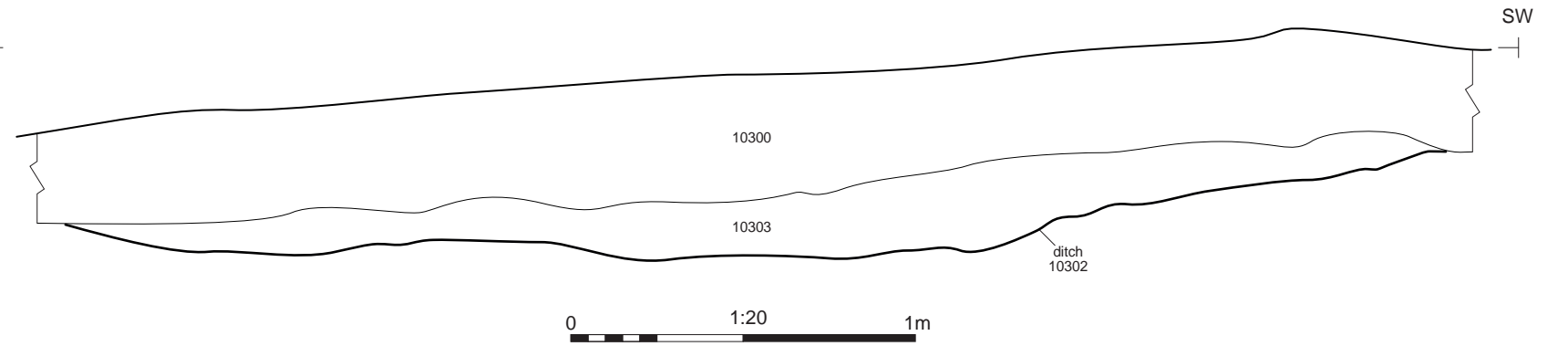

Trench 103, looking north-east (1m scales)



Ditch 10302, looking south-east (2m scale)

Cotswold Archaeology
 Andover 01264 347630
 Cirencester 01285 771022
 Milton Keynes 01908 564660
 Suffolk 01449 900120
 www.cotswoldarchaeology.co.uk
 enquiries@cotswoldarchaeology.co.uk

PROJECT TITLE
**Mallard Pass Solar Farm DCO,
 Essendine, Rutland & Lincolnshire**

FIGURE TITLE
**Area PF1 (Rutland), Trench 103: plan,
 section and photographs**

DRAWN BY	RW	PROJECT NO.	MK0789	FIGURE NO.
CHECKED BY	DJB	DATE	07/02/2023	48
APPROVED BY	AW	SCALE@A3	1:200, 1:20	

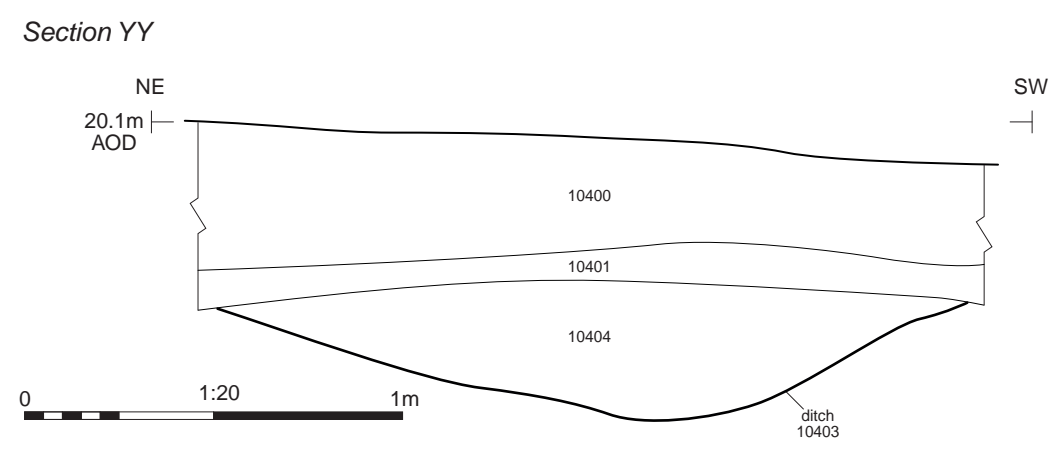
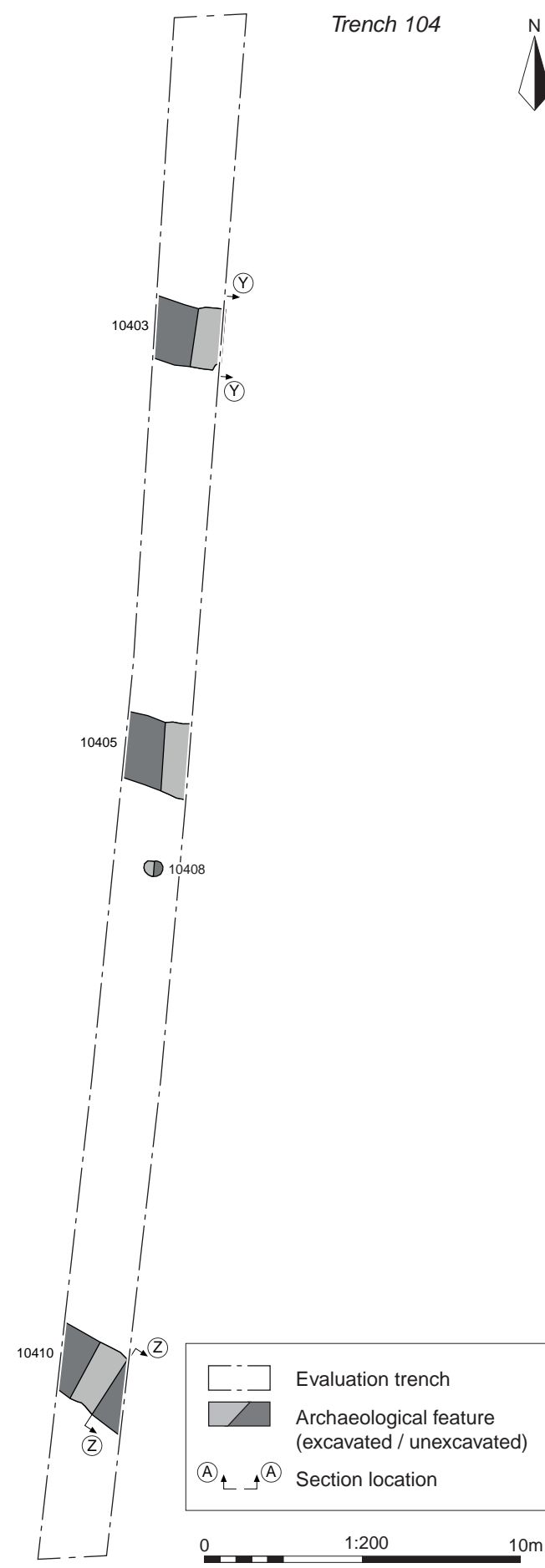

Trench 104, looking north (1m scales)



Ditch 10403, looking east (1m scale)

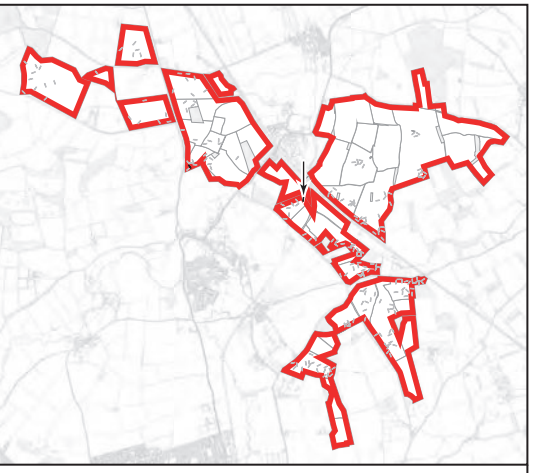

Cotswold Archaeology

Andover 01264 347630
 Cirencester 01285 771022
 Milton Keynes 01908 564660
 Suffolk 01449 900120
 www.cotswoldarchaeology.co.uk
 enquiries@cotswoldarchaeology.co.uk

PROJECT TITLE
 Mallard Pass Solar Farm DCO,
 Essendine, Rutland & Lincolnshire

FIGURE TITLE
 Area PF1 (Rutland), Trench 104: plan,
 section and photographs

DRAWN BY	RW	PROJECT NO.	MK0789	FIGURE NO.
CHECKED BY	DJB	DATE	07/02/2023	49
APPROVED BY	AW	SCALE@A3	1:200, 1:20	

Section ZZ

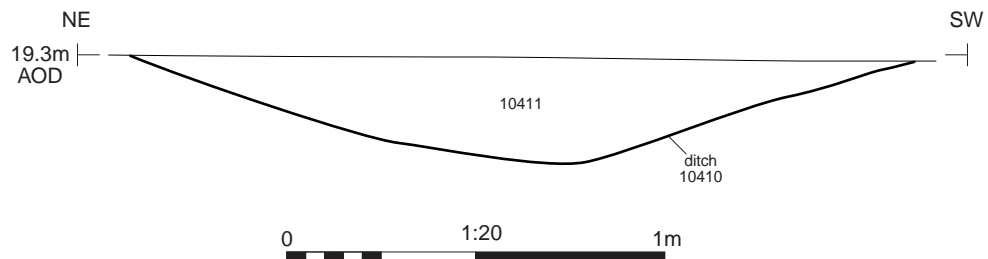

Ditch 10410, looking south-east (1m scale)



Andover 01264 347630
Cirencester 01285 771022
Milton Keynes 01908 564660
Suffolk 01449 900120
www.cotswoldarchaeology.co.uk
enquiries@cotswoldarchaeology.co.uk

PROJECT TITLE

Mallard Pass Solar Farm DCO,
Essendine, Rutland & Lincolnshire

FIGURE TITLE

**Area PF1 (Rutland), Trench 104: section
and photograph**

DRAWN BY RW PROJECT NO. MK0789
CHECKED BY DJB DATE 07/02/2023
APPROVED BY AW SCALE@A4 1:20

FIGURE NO.

50



Trench 111

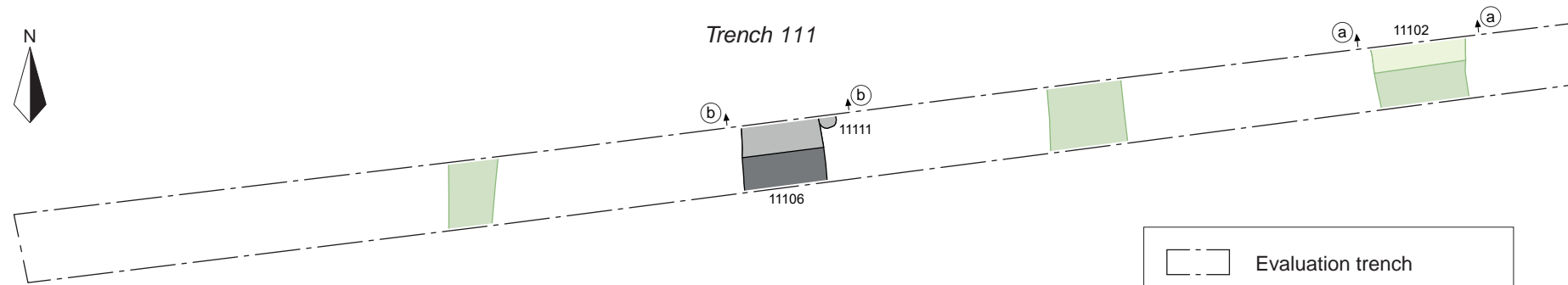

Section aa

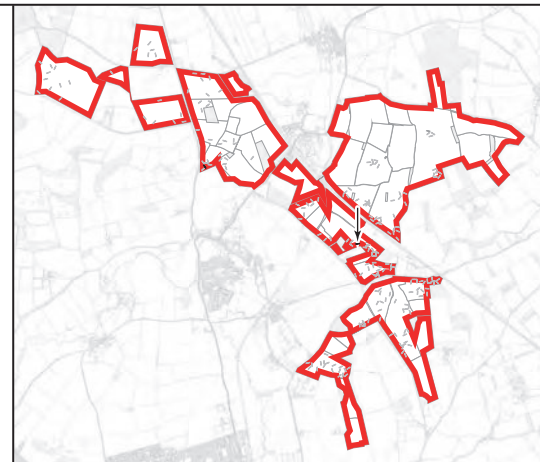
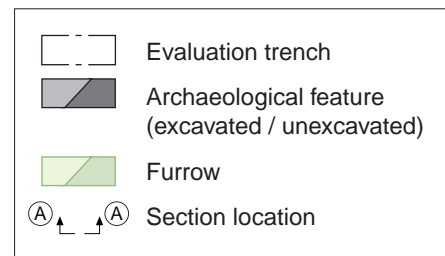
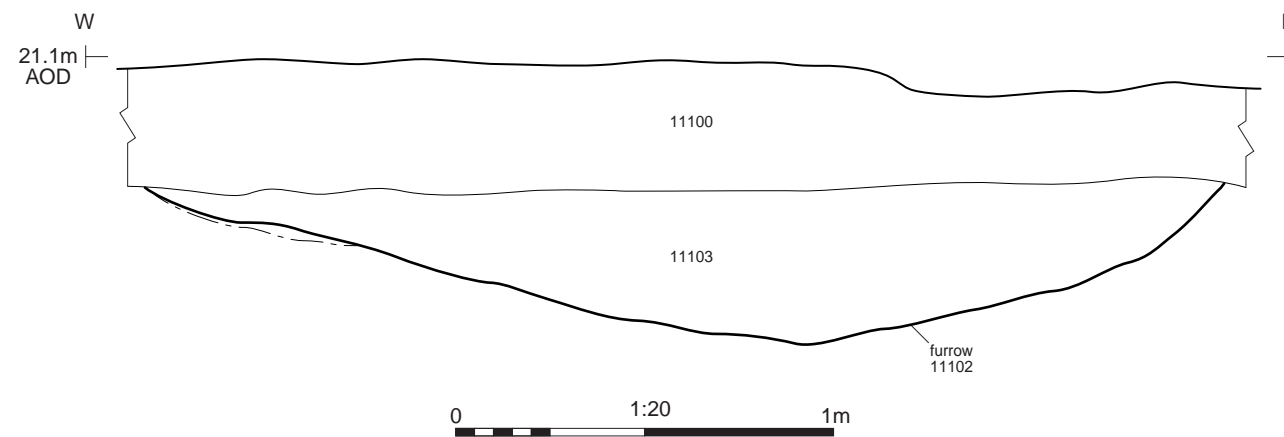

Trench 111, looking east (1m scales)



Furrow 11102, looking north (2m scale)



Cotswold Archaeology
 Andover 01264 347630
 Cirencester 01285 771022
 Milton Keynes 01908 564660
 Suffolk 01449 900120
 www.cotswoldarchaeology.co.uk
 enquiries@cotswoldarchaeology.co.uk

PROJECT TITLE
 Mallard Pass Solar Farm DCO,
 Essendine, Rutland & Lincolnshire

FIGURE TITLE
 Area PF4 (Rutland), Trench 111: plan,
 section and photographs

DRAWN BY	RW	PROJECT NO.	MK0789	FIGURE NO.
CHECKED BY	DJB	DATE	07/02/2023	51
APPROVED BY	AW	SCALE@A3	1:200, 1:20	

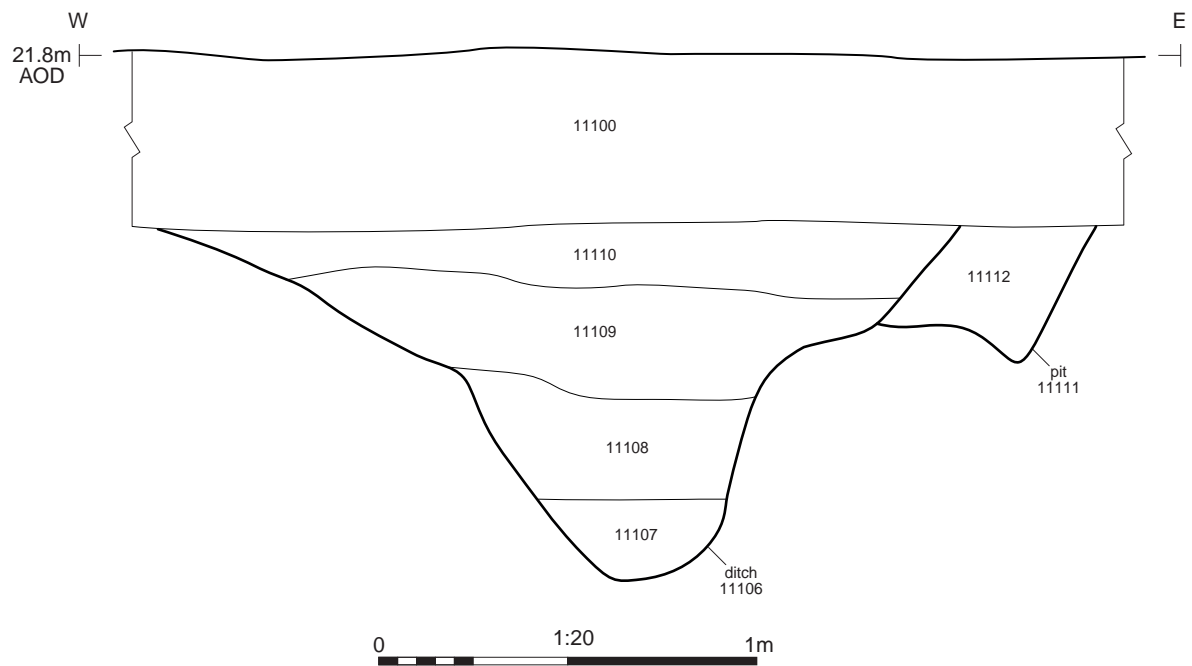
Section bb



Ditch 11106 (centre) and pit 11111 (right), looking north (1m scale)



Andover 01264 347630
 Cirencester 01285 771022
 Milton Keynes 01908 564660
 Suffolk 01449 900120
www.cotswoldarchaeology.co.uk
enquiries@cotswoldarchaeology.co.uk

PROJECT TITLE

Mallard Pass Solar Farm DCO,
 Essendine, Rutland & Lincolnshire

FIGURE TITLE

Area PF4 (Rutland), Trench 111: section
 and photograph

DRAWN BY RW PROJECT NO. MK0789
 CHECKED BY DJB DATE 07/02/2023
 APPROVED BY AW SCALE@A4 1:20



FIGURE NO.

52

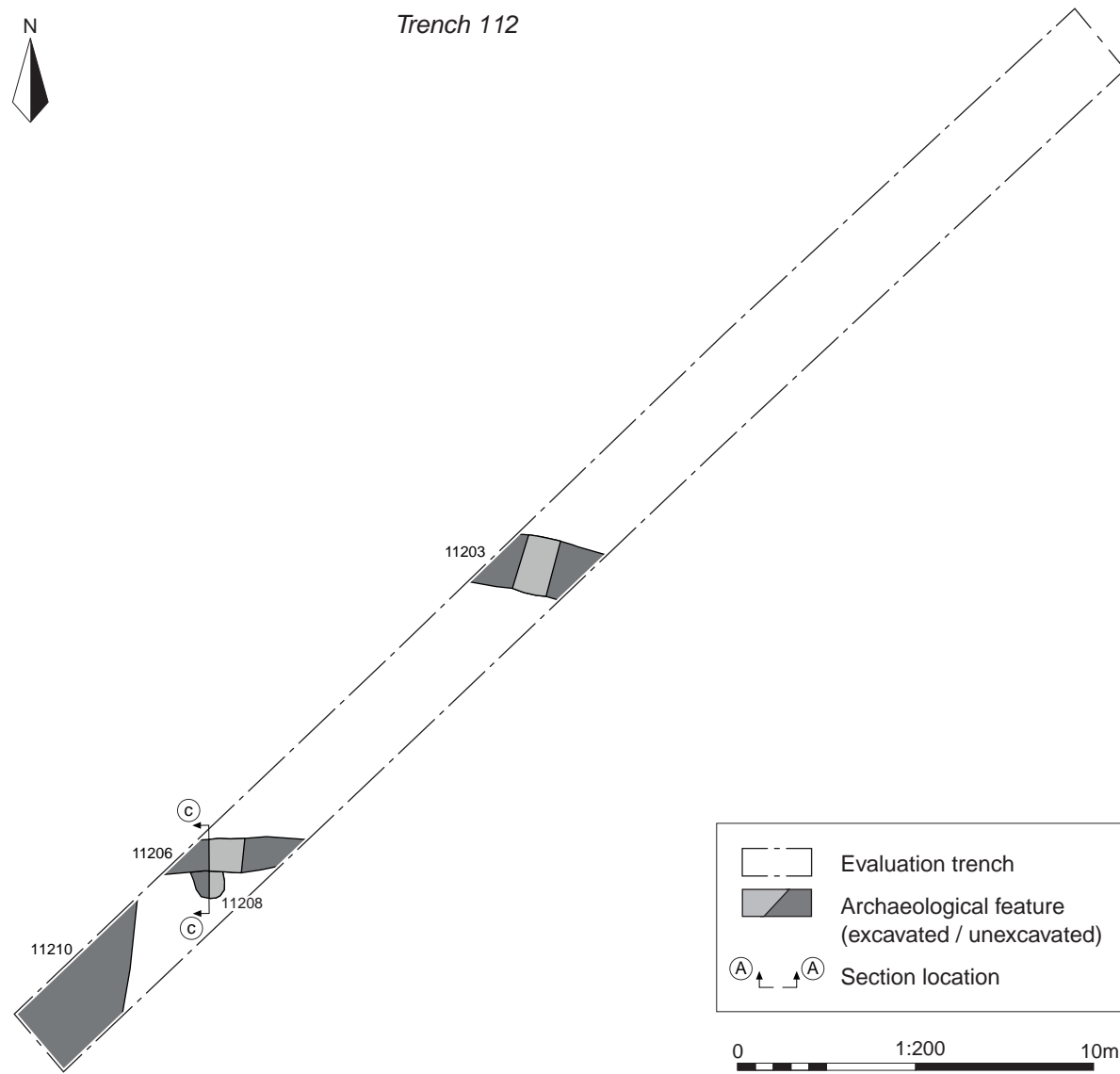

Trench 112



-  Evaluation trench
-  Archaeological feature (excavated / unexcavated)
-  Section location

0 1:200 10m

Section cc

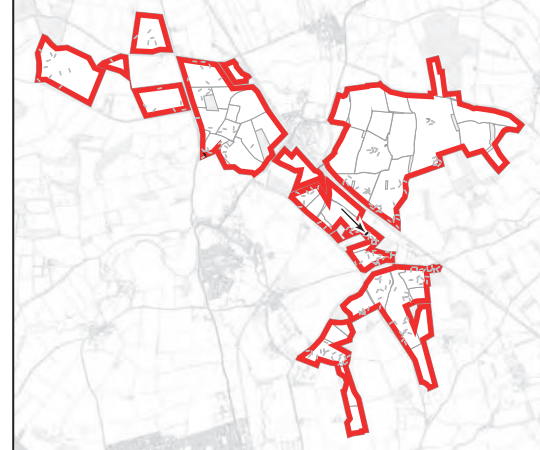
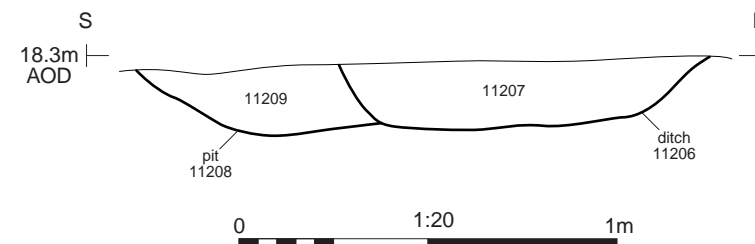

Trench 112, looking north-east (1m scales)



Pit 11208 (left) and ditch 11206 (right), looking west (1m scale)

 Andover 01264 347630
 Cirencester 01285 771022
 Milton Keynes 01908 564660
 Suffolk 01449 900120
www.cotswoldarchaeology.co.uk
enquiries@cotswoldarchaeology.co.uk

PROJECT TITLE
 Mallard Pass Solar Farm DCO,
 Essendine, Rutland & Lincolnshire

FIGURE TITLE
 Area PF5 (Rutland), Trench 112: plan,
 section and photographs

DRAWN BY	RW	PROJECT NO.	MK0789	FIGURE NO.
CHECKED BY	DJB	DATE	07/02/2023	53
APPROVED BY	AW	SCALE@A3	1:200, 1:20	

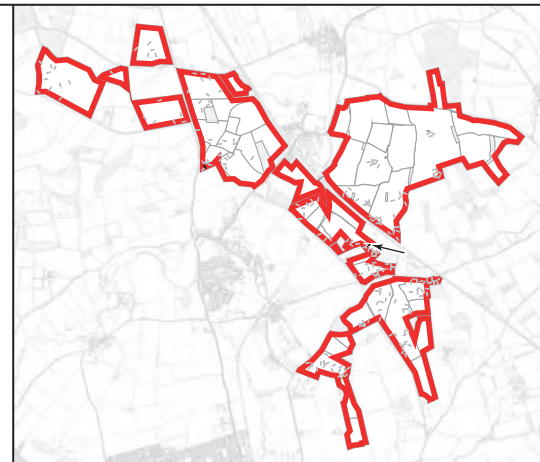
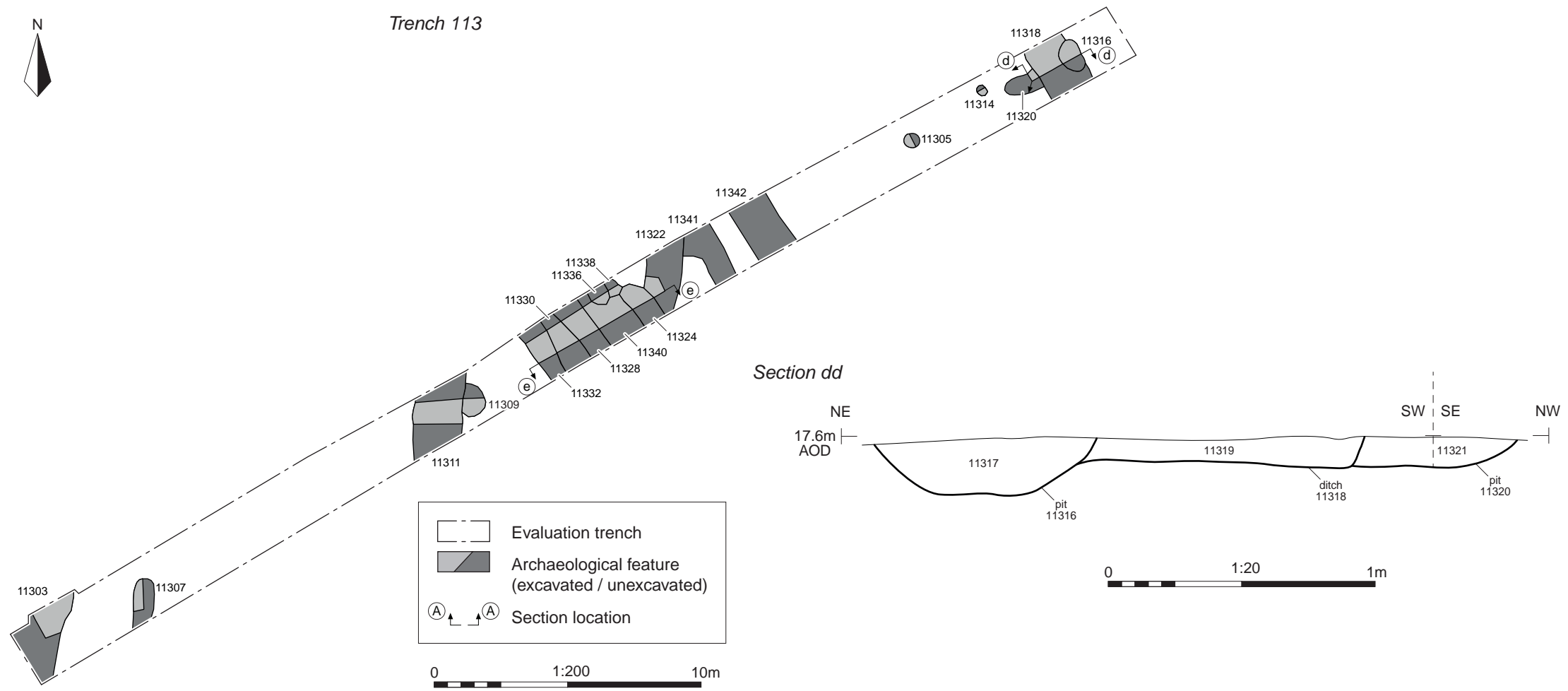

Trench 113, looking north-east (1m scales)



Pit 11316 (left), ditch 11318 (centre) and pit 11320 (right), looking south-east (1m scale)

Andover 01264 347630
 Cirencester 01285 771022
 Milton Keynes 01908 564660
 Suffolk 01449 900120
 www.cotswoldarchaeology.co.uk
 enquiries@cotswoldarchaeology.co.uk

PROJECT TITLE
 Mallard Pass Solar Farm DCO,
 Essendine, Rutland & Lincolnshire

FIGURE TITLE
 Area PF5 (Rutland), Trench 113: plan,
 section and photographs

DRAWN BY RW PROJECT NO. MK0789 FIGURE NO.
 CHECKED BY DJB DATE 07/02/2023
 APPROVED BY AW SCALE@A3 1:200, 1:20 54

Section ee

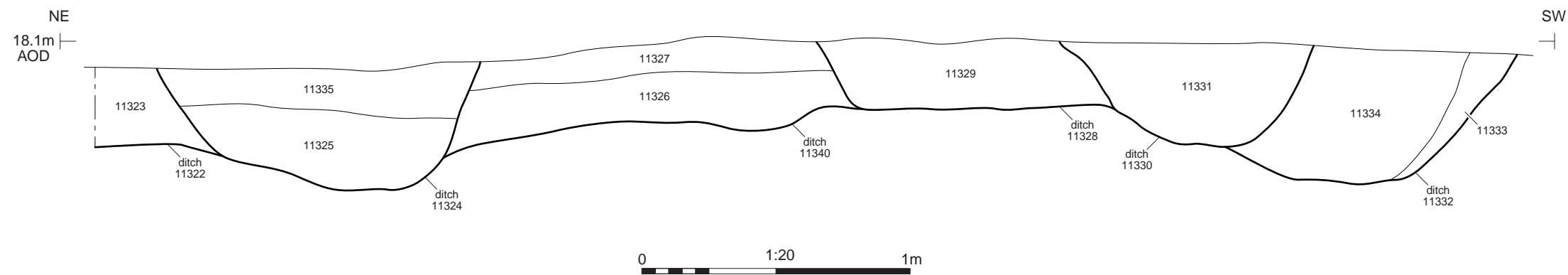

Ditches 11322, 11324, 11340, 11328, 11330 and 11332 (left to right), looking south-east (1m scales)

Cotswold Archaeology
 Andover 01264 347630
 Cirencester 01285 771022
 Milton Keynes 01908 564660
 Suffolk 01449 900120
www.cotswoldarchaeology.co.uk
enquiries@cotswoldarchaeology.co.uk

PROJECT TITLE
 Mallard Pass Solar Farm DCO,
 Essendine, Rutland & Lincolnshire

FIGURE TITLE
 Area PF5 (Rutland), Trench 113:
 section and photograph

DRAWN BY	RW	PROJECT NO.	MK0789	FIGURE NO.
CHECKED BY	DJB	DATE	07/02/2023	55
APPROVED BY	AW	SCALE@A3	1:20	

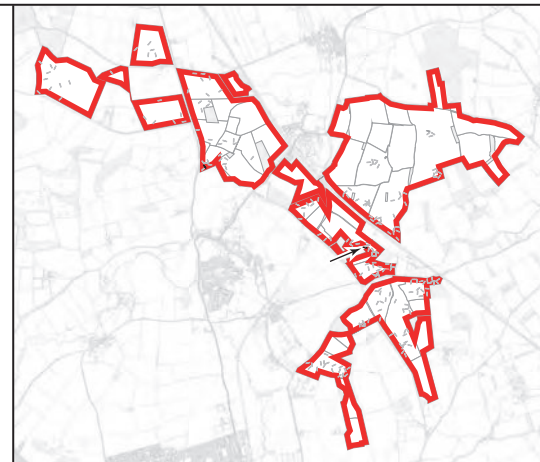
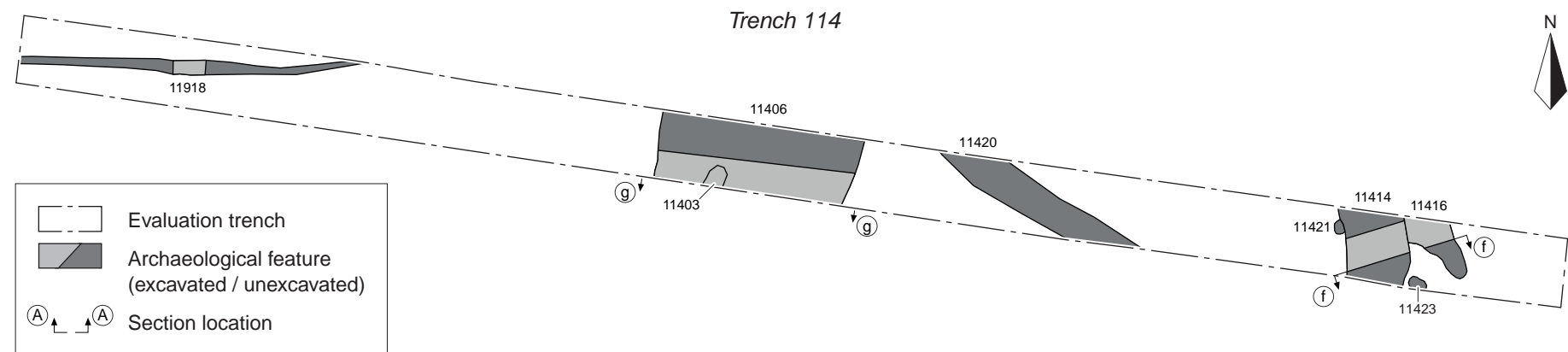

Section ff

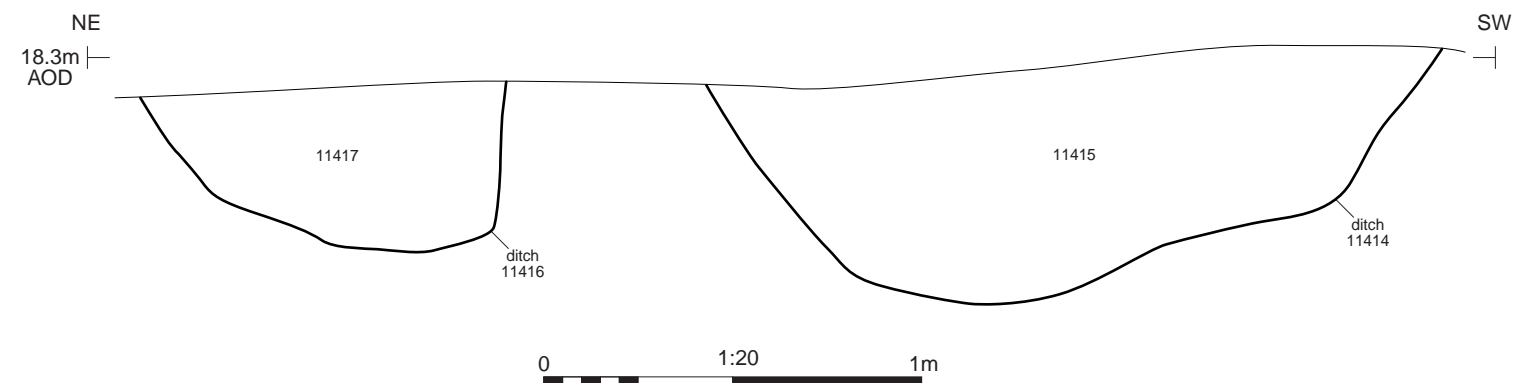

Trench 114, looking west (1m scales)



Ditches 11416 (left) and 11414 (right), looking south-east (0.5m and 1m scale)

Cotswold Archaeology
 Andover 01264 347630
 Cirencester 01285 771022
 Milton Keynes 01908 564660
 Suffolk 01449 900120
 www.cotswoldarchaeology.co.uk
 enquiries@cotswoldarchaeology.co.uk

PROJECT TITLE
 Mallard Pass Solar Farm DCO,
 Essendine, Rutland & Lincolnshire

FIGURE TITLE
 Area PF5 (Rutland), Trench 114: plan,
 section and photographs

DRAWN BY	RW	PROJECT NO.	MK0789	FIGURE NO.
CHECKED BY	DJB	DATE	07/02/2023	56
APPROVED BY	AW	SCALE@A3	1:200, 1:20	

Section gg

E
19.0m
AOD

W

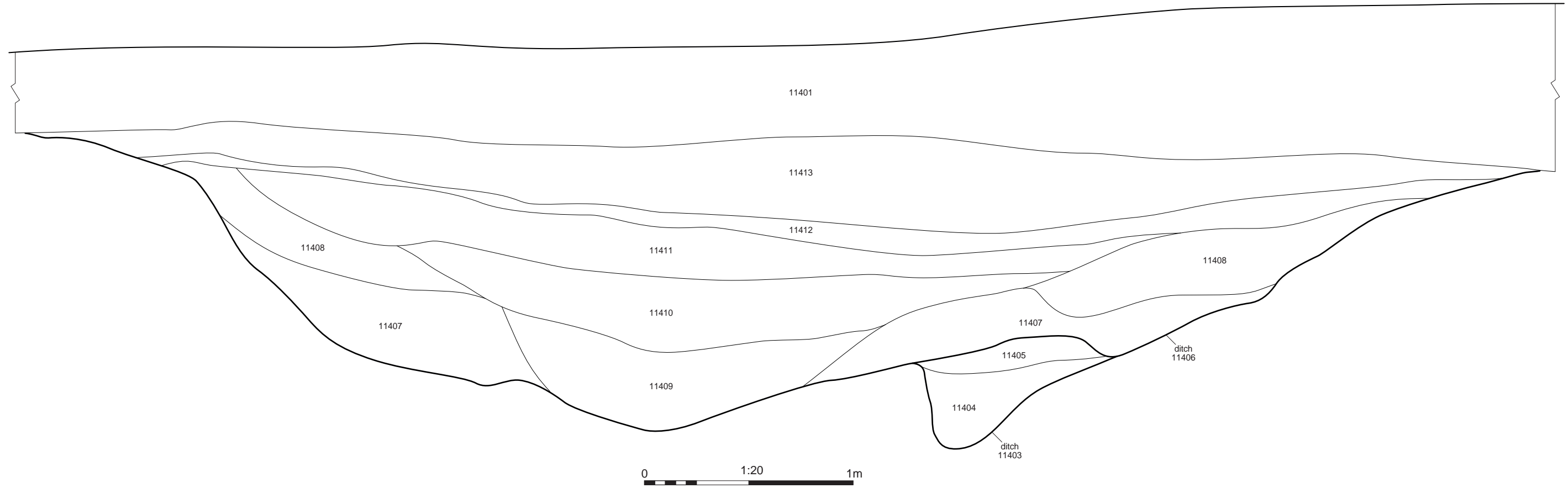

Ditches 11403 and 11406, looking south-east (1m scales)

Cotswold Archaeology
 Andover 01264 347630
 Cirencester 01285 771022
 Milton Keynes 01908 564660
 Suffolk 01449 900120
 www.cotswoldarchaeology.co.uk
 enquiries@cotswoldarchaeology.co.uk

PROJECT TITLE
**Mallard Pass Solar Farm DCO,
 Essendine, Rutland & Lincolnshire**

FIGURE TITLE
**Area PF5 (Rutland), Trench 114:
 section and photograph**

DRAWN BY	RW	PROJECT NO.	MK0789	FIGURE NO.
CHECKED BY	DJB	DATE	07/02/2023	57
APPROVED BY	AW	SCALE@A3	1:20	



Trench 115

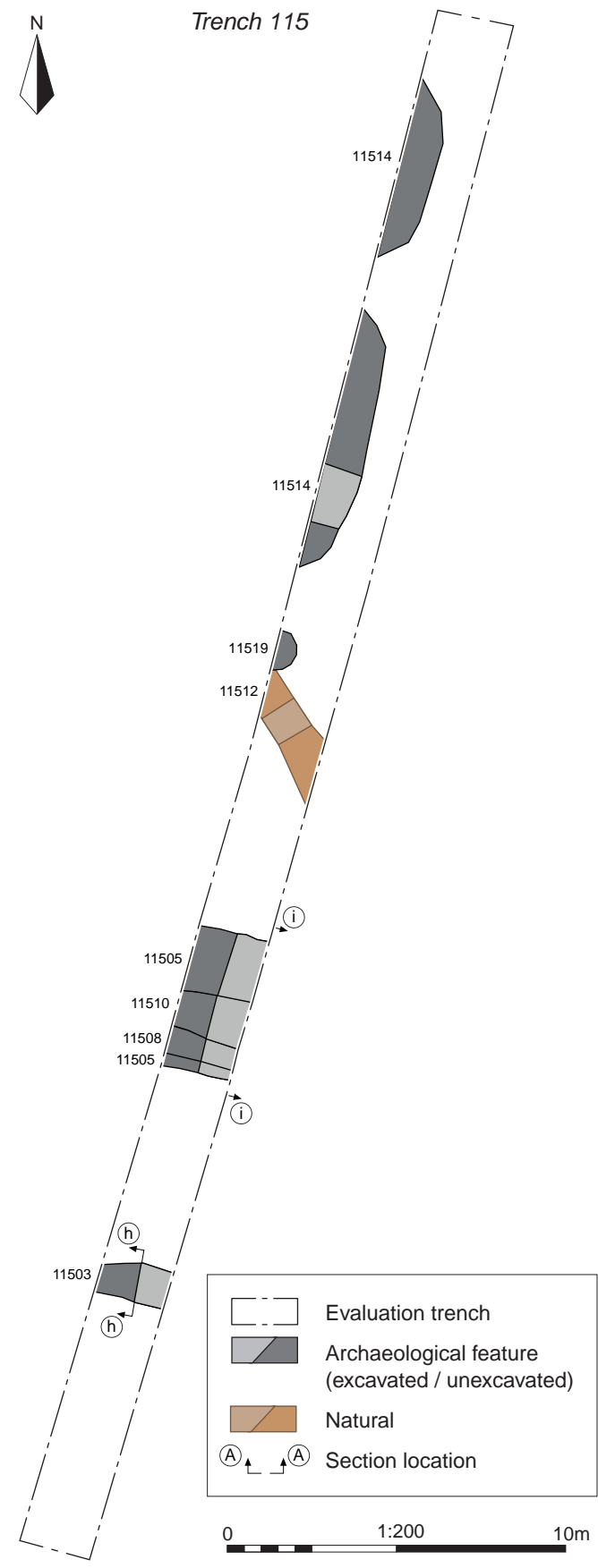

Section hh

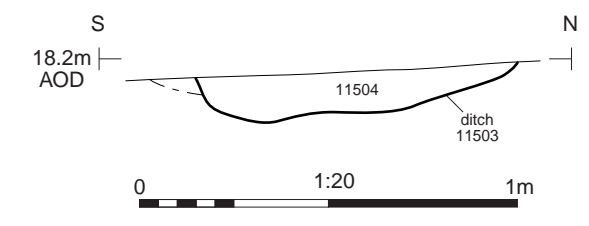

Trench 115, looking south-west (1m scales)



Ditch 11503, looking west (0.5m scale)

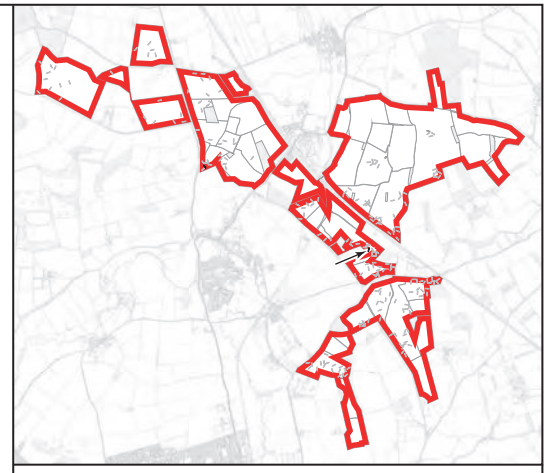



 Andover 01264 347630
 Cirencester 01285 771022
 Milton Keynes 01908 564660
 Suffolk 01449 900120
www.cotswoldarchaeology.co.uk
enquiries@cotswoldarchaeology.co.uk

PROJECT TITLE
Mallard Pass Solar Farm DCO,
Essendine, Rutland & Lincolnshire

FIGURE TITLE
Area PF5 (Rutland), Trench 115: plan,
section and photographs

DRAWN BY	RW	PROJECT NO.	MK0789	FIGURE NO.
CHECKED BY	DJB	DATE	07/02/2023	58
APPROVED BY	AW	SCALE@A3	1:200, 1:20	

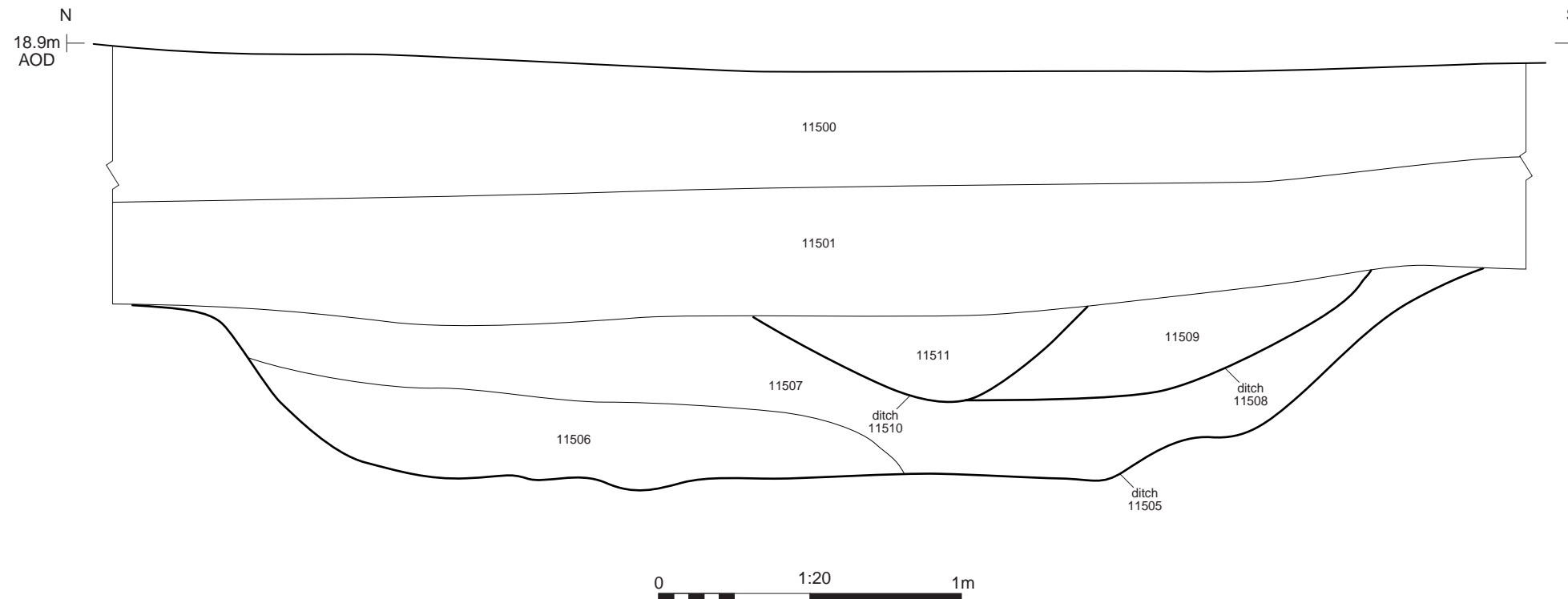
Section ii



Ditches 11505, 11508 and 11510, looking east (1m scale)

Cotswold Archaeology
 Andover 01264 347630
 Cirencester 01285 771022
 Milton Keynes 01908 564660
 Suffolk 01449 900120
www.cotswoldarchaeology.co.uk
enquiries@cotswoldarchaeology.co.uk

PROJECT TITLE
 Mallard Pass Solar Farm DCO,
 Essendine, Rutland & Lincolnshire

FIGURE TITLE
 Area PF5 (Rutland), Trench 115:
 section and photograph

DRAWN BY	RW	PROJECT NO.	MK0789	FIGURE NO.
CHECKED BY	DJB	DATE	07/02/2023	59
APPROVED BY	AW	SCALE@A3	1:20	

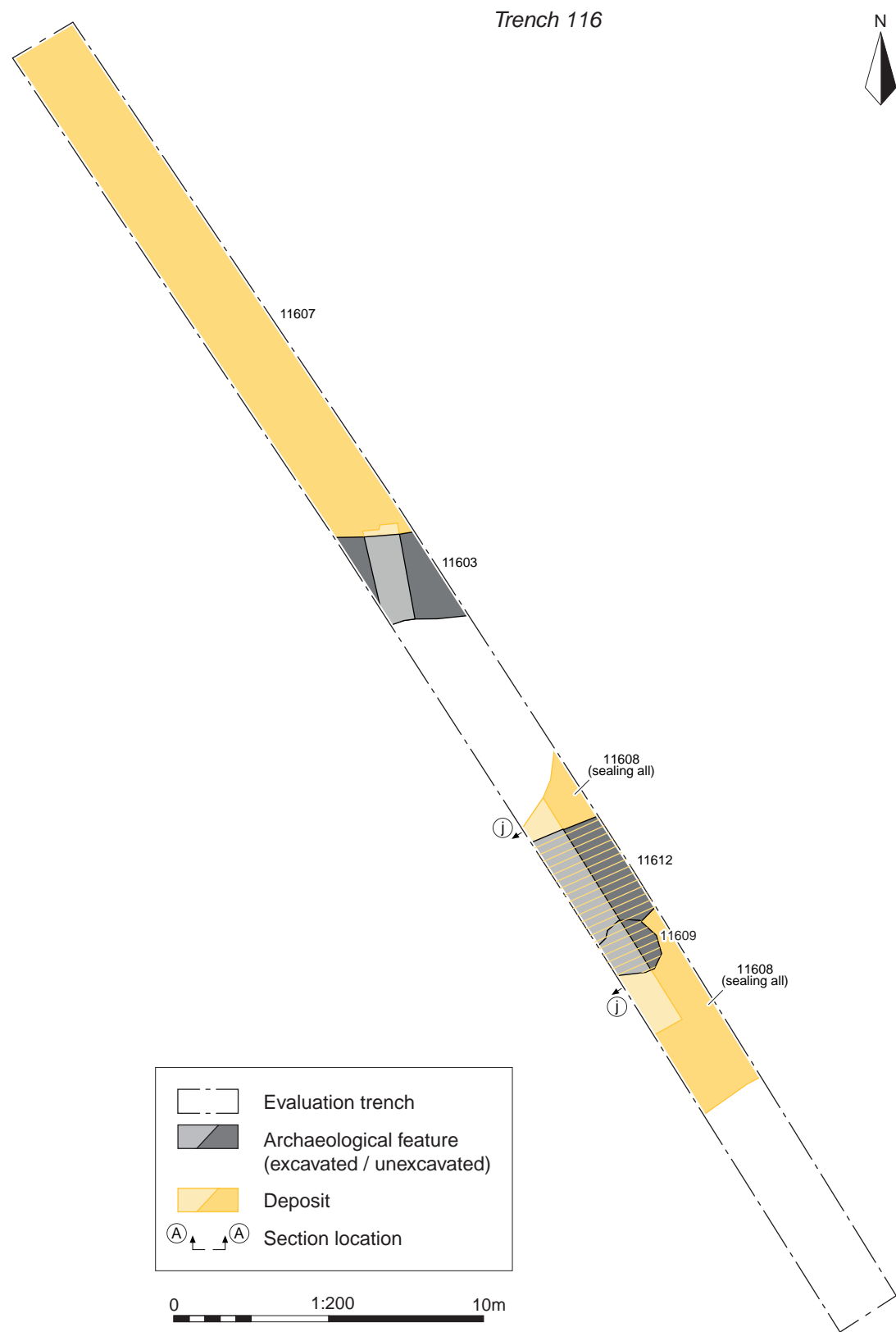

Trench 116, looking south-east (1m scales)

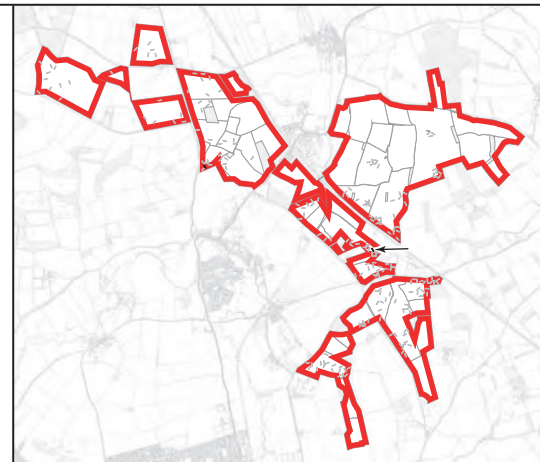

[Cotswold Archaeology](http://www.cotswoldarchaeology.co.uk)
 Andover 01264 347630
 Cirencester 01285 771022
 Milton Keynes 01908 564660
 Suffolk 01449 900120
 www.cotswoldarchaeology.co.uk
 enquiries@cotswoldarchaeology.co.uk

PROJECT TITLE
**Mallard Pass Solar Farm DCO,
 Essendine, Rutland & Lincolnshire**

FIGURE TITLE
**Area PF5 (Rutland), Trench 116: plan
 and photograph**

DRAWN BY	RW	PROJECT NO.	MK0789	FIGURE NO.
CHECKED BY	DJB	DATE	07/02/2023	60
APPROVED BY	AW	SCALE@A3	1:200	

Section *jj*

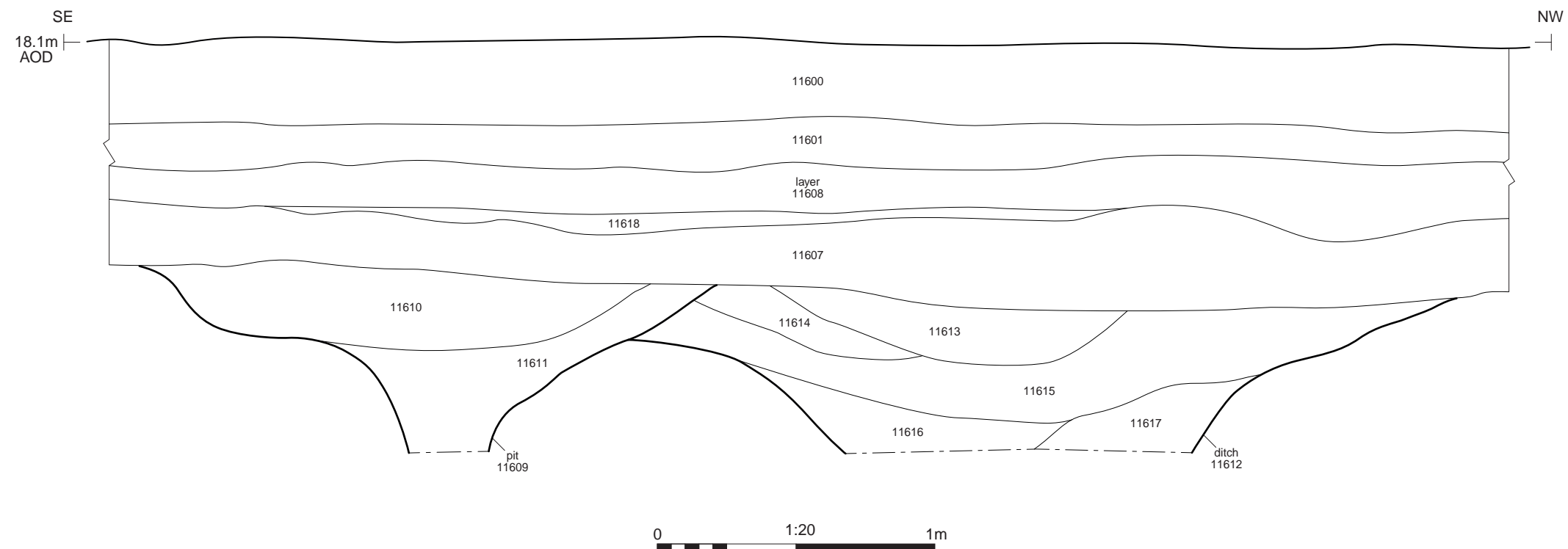

Pit 11609 (upper-left) and ditch 11612 (centre) sealed by 11608, looking south-west (2m scale)

Cotswold Archaeology
 Andover 01264 347630
 Cirencester 01285 771022
 Milton Keynes 01908 564660
 Suffolk 01449 900120
www.cotswoldarchaeology.co.uk
enquiries@cotswoldarchaeology.co.uk

PROJECT TITLE
 Mallard Pass Solar Farm DCO,
 Essendine, Rutland & Lincolnshire

FIGURE TITLE
 Area PF5 (Rutland), Trench 116:
 section and photograph

DRAWN BY	RW	PROJECT NO.	MK0789	FIGURE NO.
CHECKED BY	DJB	DATE	07/02/2023	61
APPROVED BY	AW	SCALE@A3	1:20	

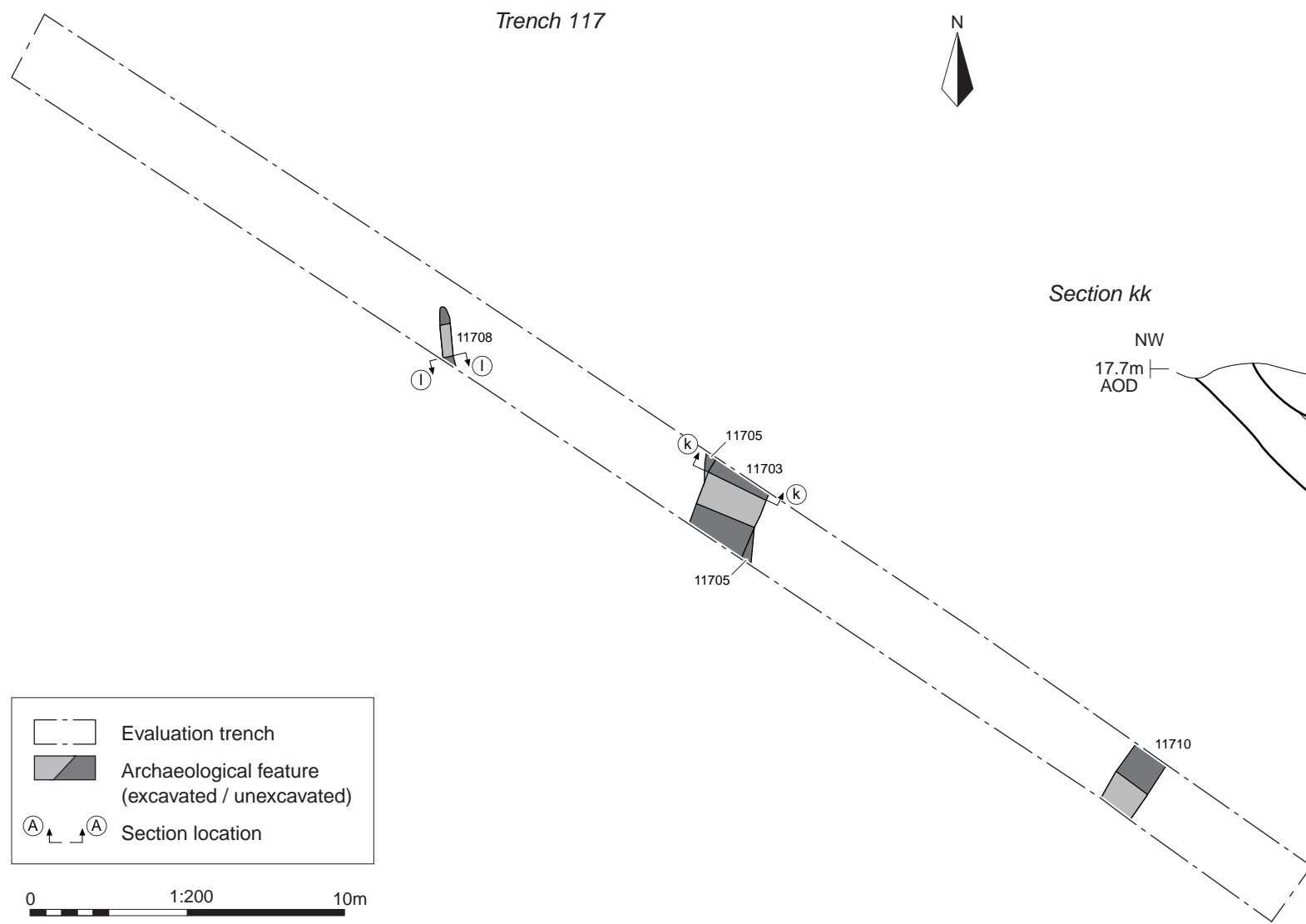

Section kk

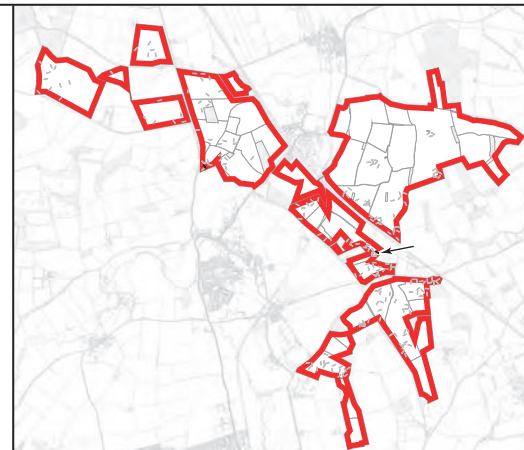
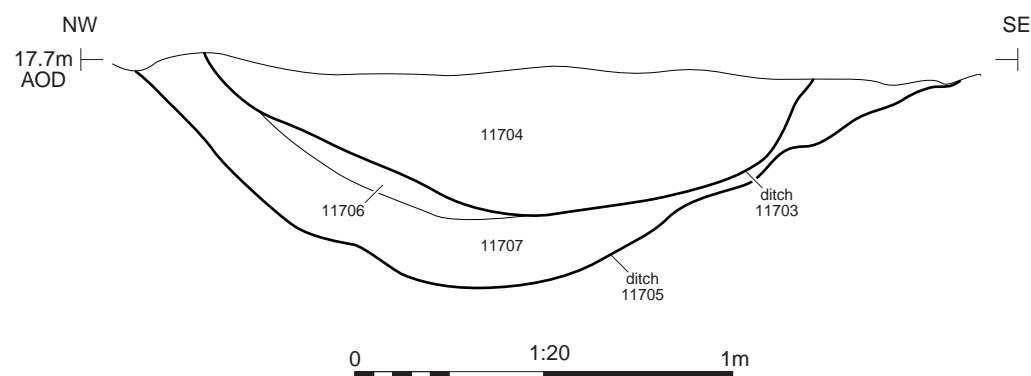

Trench 117, looking south-east (1m scales)



Ditches 11705 and 11703, looking north-east (2m scale)

Cotswold Archaeology

Andover 01264 347630
 Cirencester 01285 771022
 Milton Keynes 01908 564660
 Suffolk 01449 900120
 www.cotswoldarchaeology.co.uk
 enquiries@cotswoldarchaeology.co.uk

PROJECT TITLE
 Mallard Pass Solar Farm DCO,
 Essendine, Rutland & Lincolnshire

FIGURE TITLE
 Area PF7 (Rutland), Trench 117: plan,
 section and photographs

Section II

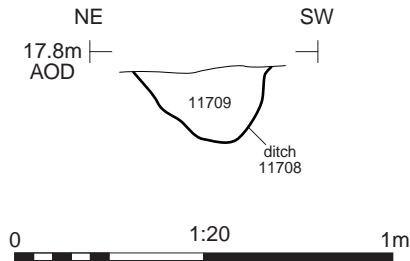

Ditch 11706, looking south (0.2m scale)



Andover 01264 347630
Cirencester 01285 771022
Milton Keynes 01908 564660
Suffolk 01449 900120
www.cotswoldarchaeology.co.uk
enquiries@cotswoldarchaeology.co.uk

PROJECT TITLE

Mallard Pass Solar Farm DCO,
Essendine, Rutland & Lincolnshire

FIGURE TITLE

Area PF7 (Rutland), Trench 117: section
and photograph

DRAWN BY RW PROJECT NO. MK0789
CHECKED BY DJB DATE 07/02/2023
APPROVED BY AW SCALE@A4 1:20

FIGURE NO.

63

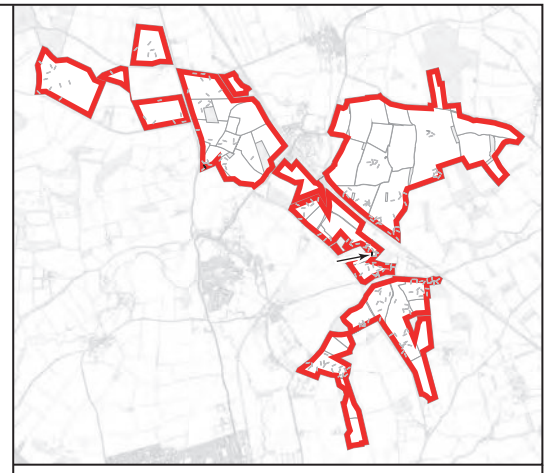
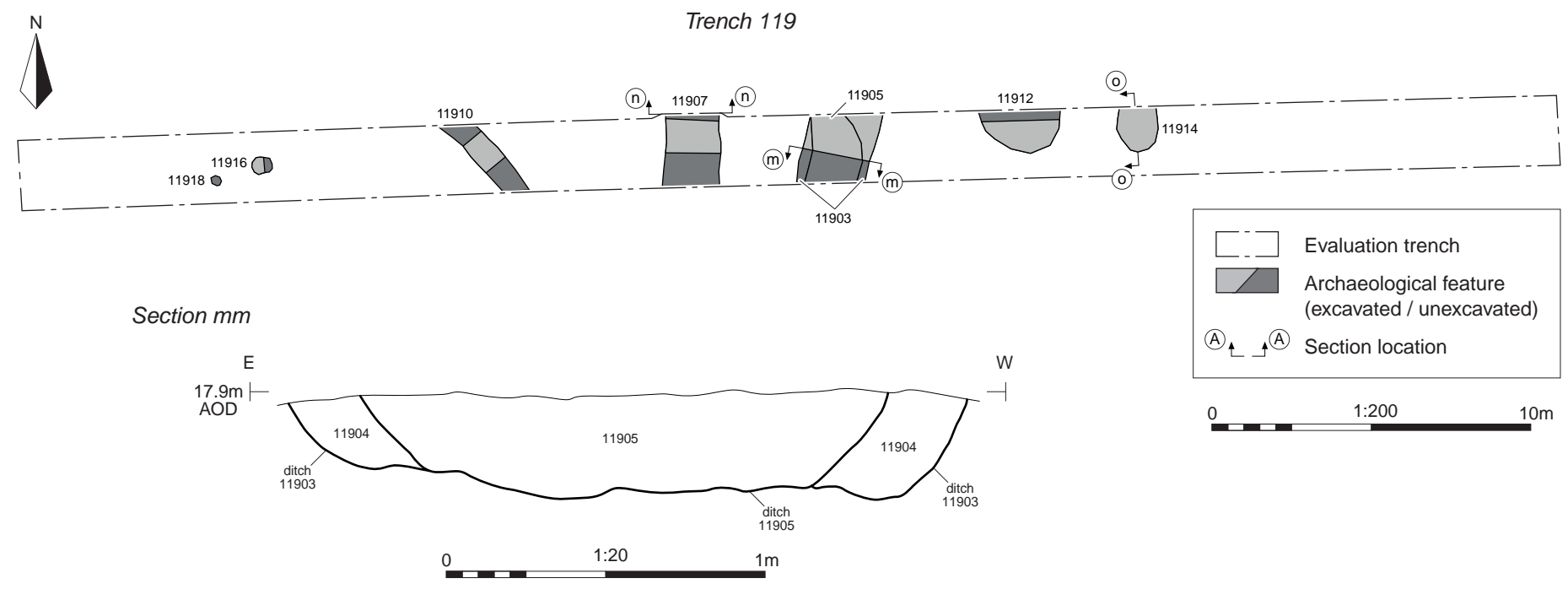

Trench 119, looking east (1m scales)



Ditches 11903 and 11905, looking south (1m scale)

Andover 01264 347630
 Cirencester 01285 771022
 Milton Keynes 01908 564660
 Suffolk 01449 900120
 www.cotswoldarchaeology.co.uk
 enquiries@cotswoldarchaeology.co.uk

PROJECT TITLE
 Mallard Pass Solar Farm DCO,
 Essendine, Rutland & Lincolnshire

FIGURE TITLE
 Area PF7 (Rutland), Trench 119: plan,
 section and photographs

DRAWN BY RW PROJECT NO. MK0789 FIGURE NO.
 CHECKED BY DJB DATE 07/02/2023 64
 APPROVED BY AW SCALE@A3 1:200, 1:20

Section nn



Section oo

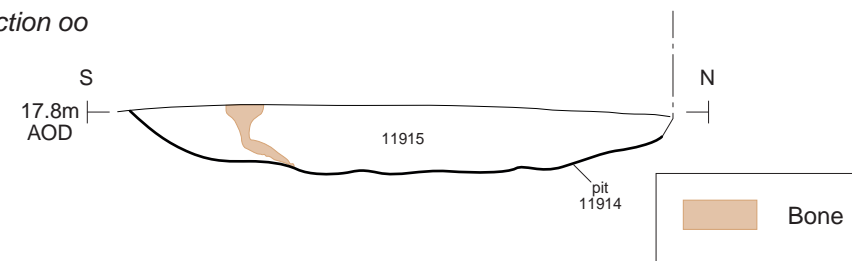

Dich 11907, looking north (1m scales)



Pit 11914, looking west (1m scale)

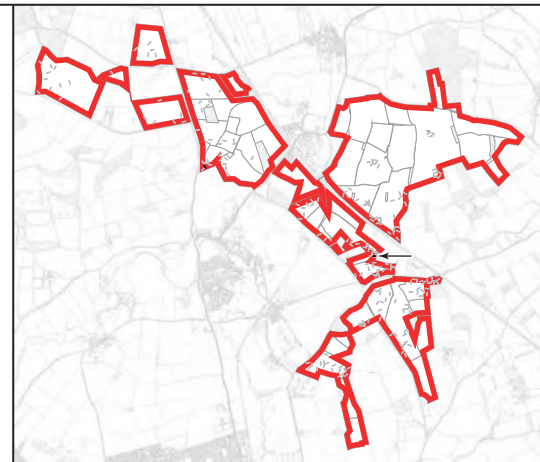
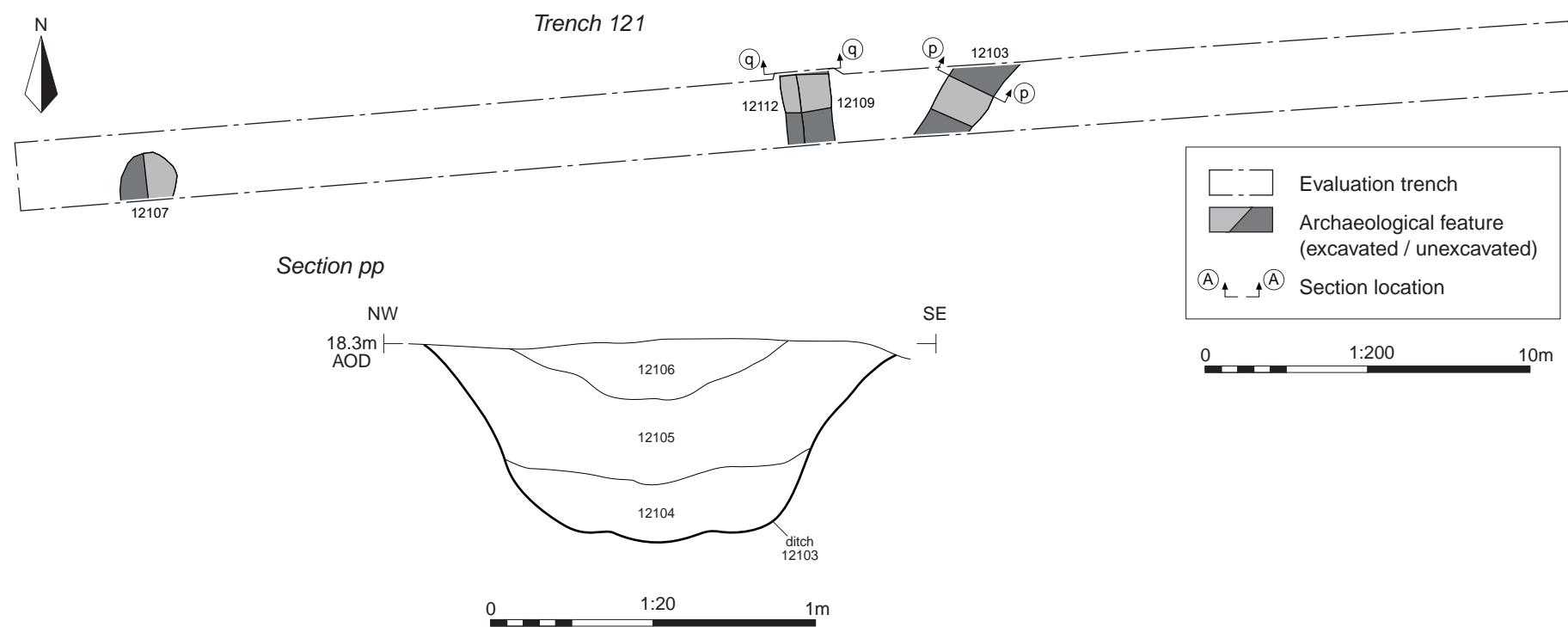

Trench 121, looking west (1m scales)



Ditch 12103, looking north-east (1m scale)

Andover 01264 347630
 Cirencester 01285 771022
 Milton Keynes 01908 564660
 Suffolk 01449 900120
 www.cotswoldarchaeology.co.uk
 enquiries@cotswoldarchaeology.co.uk

PROJECT TITLE
 Mallard Pass Solar Farm DCO,
 Essendine, Rutland & Lincolnshire

FIGURE TITLE
 Area PF7 (Rutland), Trench 121: plan,
 section and photographs

DRAWN BY	RW	PROJECT NO.	MK0789	FIGURE NO.
CHECKED BY	DJB	DATE	07/02/2023	66
APPROVED BY	AW	SCALE@A3	1:200, 1:20	

Section qq

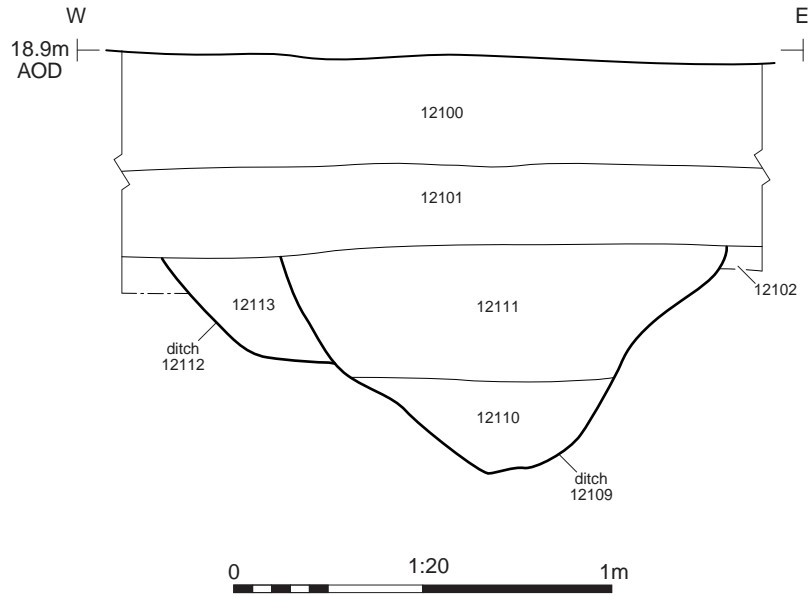

Ditches 12112 (left) and 12109 (right), looking north (1m scale)



Andover 01264 347630
 Cirencester 01285 771022
 Milton Keynes 01908 564660
 Suffolk 01449 900120
 www.cotswoldarchaeology.co.uk
 enquiries@cotswoldarchaeology.co.uk

PROJECT TITLE

Mallard Pass Solar Farm DCO,
 Essendine, Rutland & Lincolnshire

FIGURE TITLE

Area PF7 (Rutland), Trench 121: section
 and photograph

DRAWN BY RW PROJECT NO. MK0789
 CHECKED BY DJB DATE 07/02/2023
 APPROVED BY AW SCALE@A4 1:20

FIGURE NO.

67



Trench 129

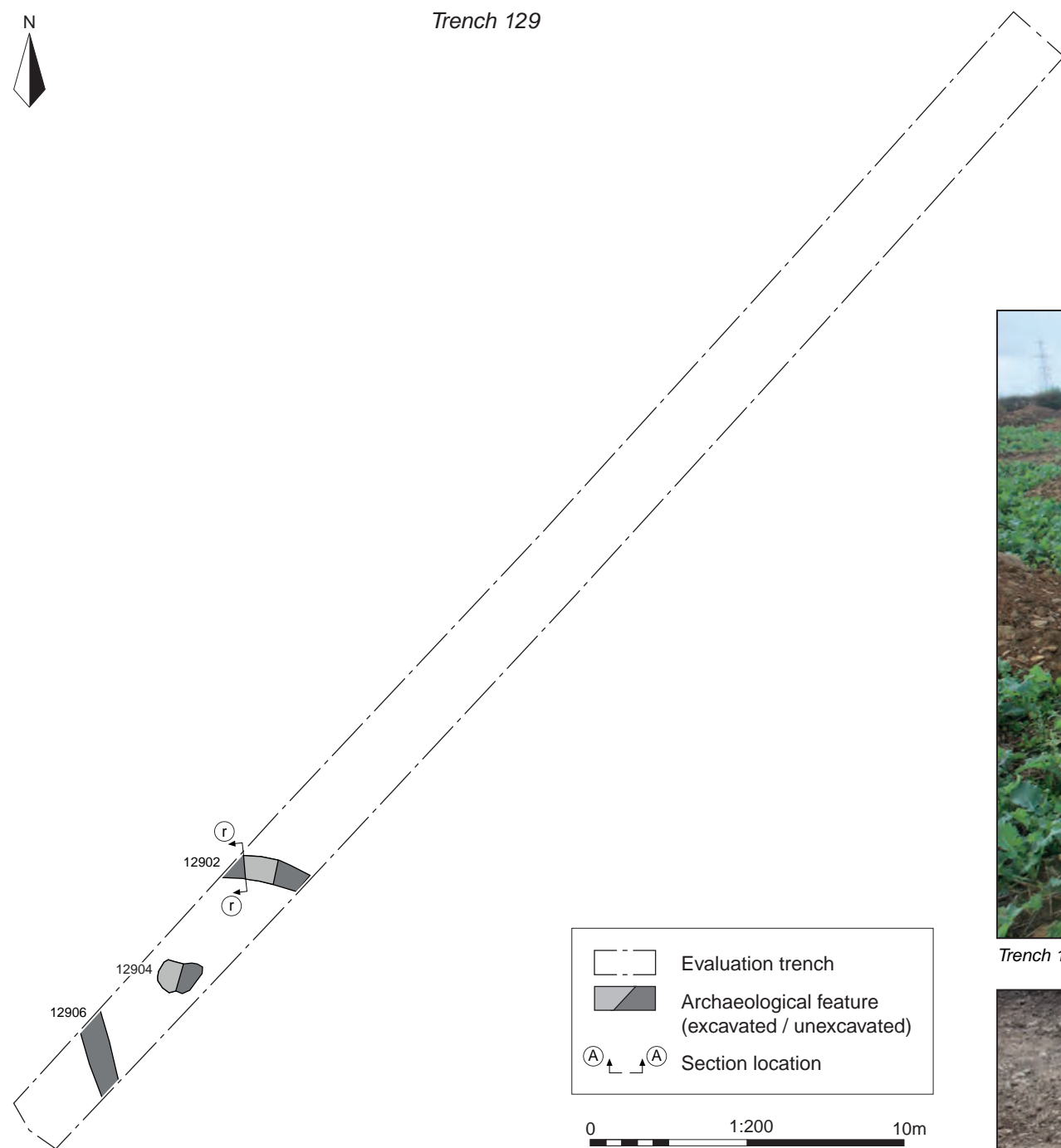

Legend:

- Evaluation trench
- Archaeological feature (excavated / unexcavated)
- Section location

0 1:200 10m

Section rr

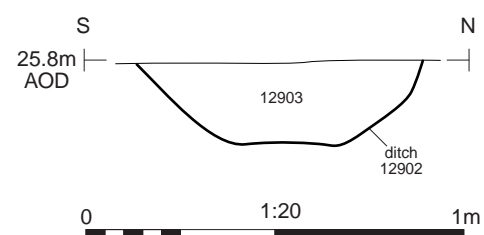

Trench 129, looking south-west (1m scales)



Ditch 12902, looking west (0.5m scale)

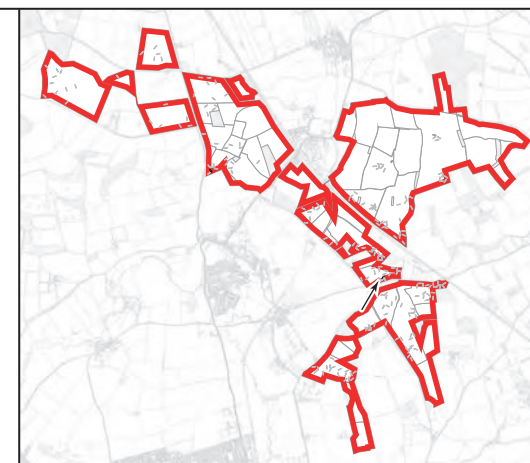

 Cotswold Archaeology

Andover 01264 347630
Cirencester 01285 771022
Milton Keynes 01908 564660
Suffolk 01449 900120
www.cotswoldarchaeology.co.uk
enquiries@cotswoldarchaeology.co.uk

PROJECT TITLE
Mallard Pass Solar Farm DCO,
Essendine, Rutland & Lincolnshire

FIGURE TITLE
Area PF8 (Rutland), Trench 129: plan,
section and photographs

DRAWN BY RW PROJECT NO. MK0789 FIGURE NO.
CHECKED BY DJB DATE 07/02/2023
APPROVED BY AW SCALE@A3 1:200, 1:20 68



Trench 130

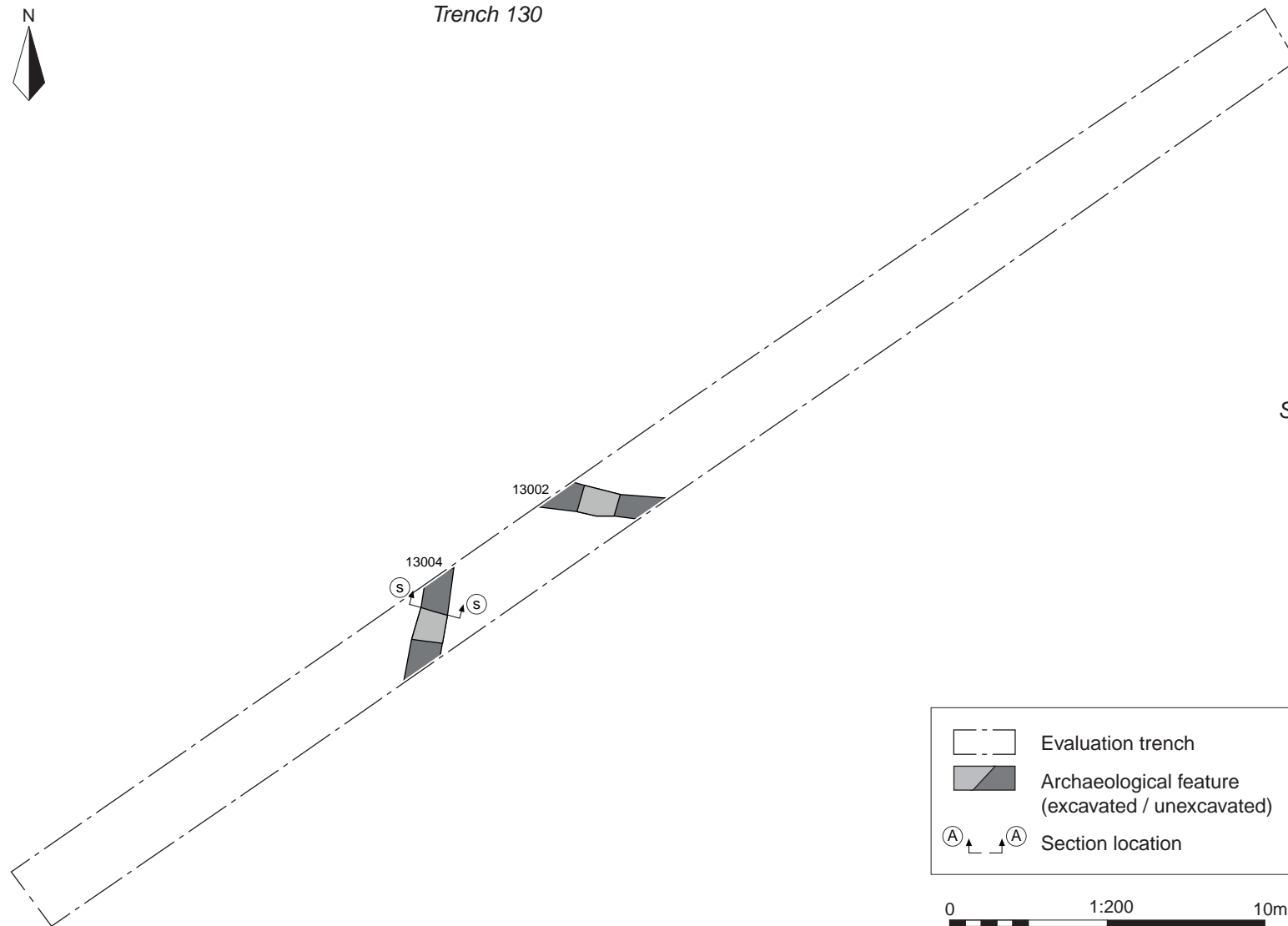

- Evaluation trench
- Archaeological feature (excavated / unexcavated)
- Section location

Section ss

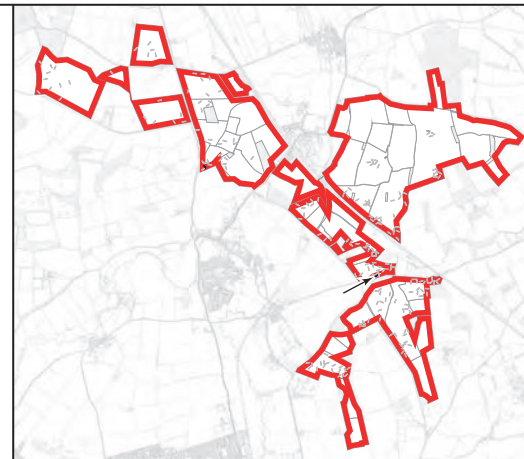
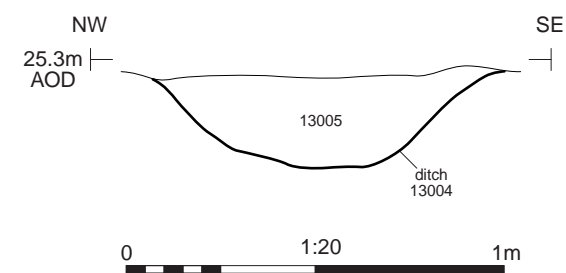

Trench 130, looking south-west (1m scales)



Ditch 13004, looking north (0.5m scale)

 Andover 01264 347630
 Cirencester 01285 771022
 Milton Keynes 01908 564660
 Suffolk 01449 900120
www.cotswoldarchaeology.co.uk
enquiries@cotswoldarchaeology.co.uk

PROJECT TITLE
 Mallard Pass Solar Farm DCO,
 Essendine, Rutland & Lincolnshire

FIGURE TITLE
 Area PF8 (Rutland), Trench 130: plan,
 section and photographs

DRAWN BY	RW	PROJECT NO.	MK0789	FIGURE NO.
CHECKED BY	DJB	DATE	07/02/2023	69
APPROVED BY	AW	SCALE@A3	1:200, 1:20	



Trench 136

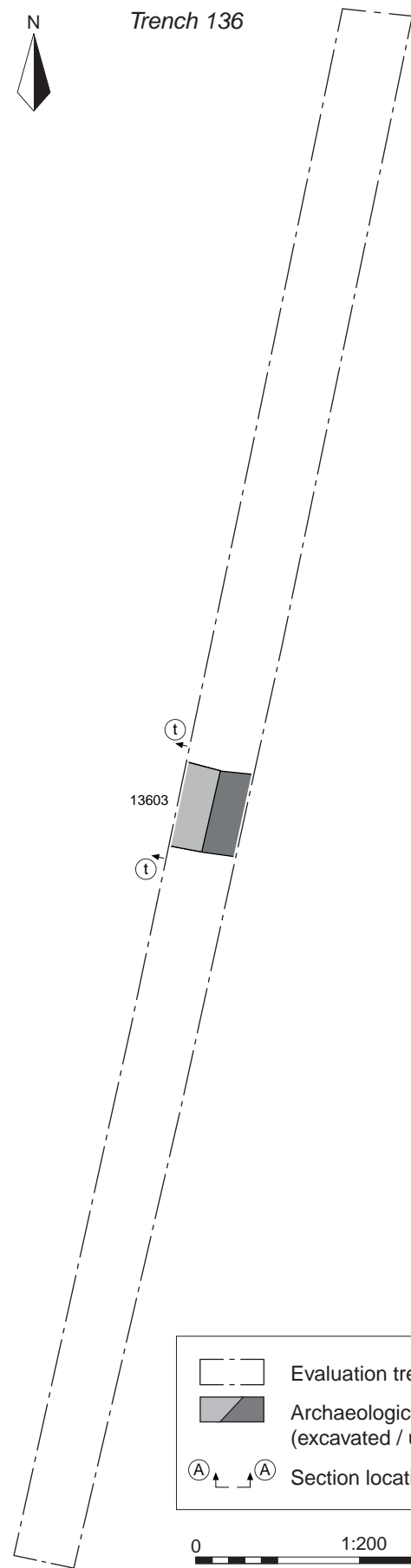

	Evaluation trench
	Archaeological feature (excavated / unexcavated)
	Section location

0 1:200 10m

Section tt

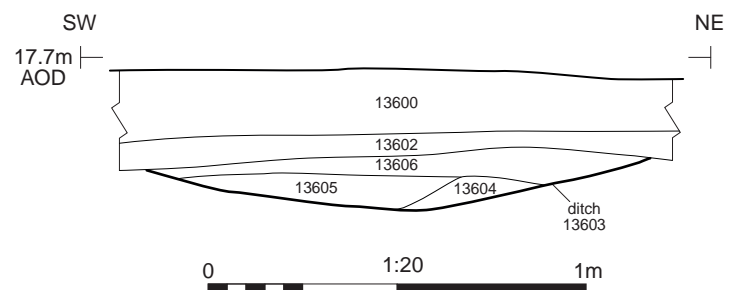

Trench 136, looking south-west (1m scales)



Ditch 13603, looking east (1m scale)

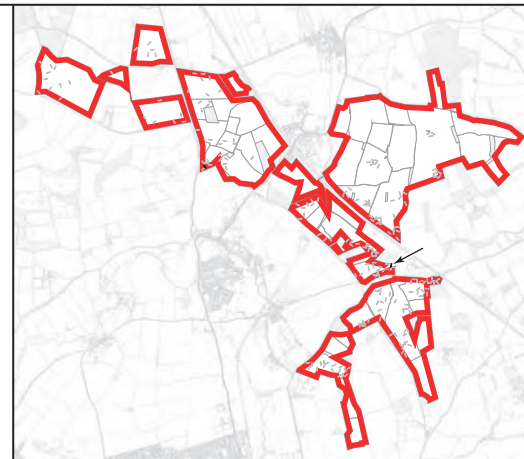

Cotswold Archaeology

Andover 01264 347630
 Cirencester 01285 771022
 Milton Keynes 01908 564660
 Suffolk 01449 900120
 www.cotswoldarchaeology.co.uk
 enquiries@cotswoldarchaeology.co.uk

PROJECT TITLE
Mallard Pass Solar Farm DCO,
Essendine, Rutland & Lincolnshire

FIGURE TITLE
Area PF8 (Lincolnshire), Trench 136:
plan, section and photographs



Trench 142

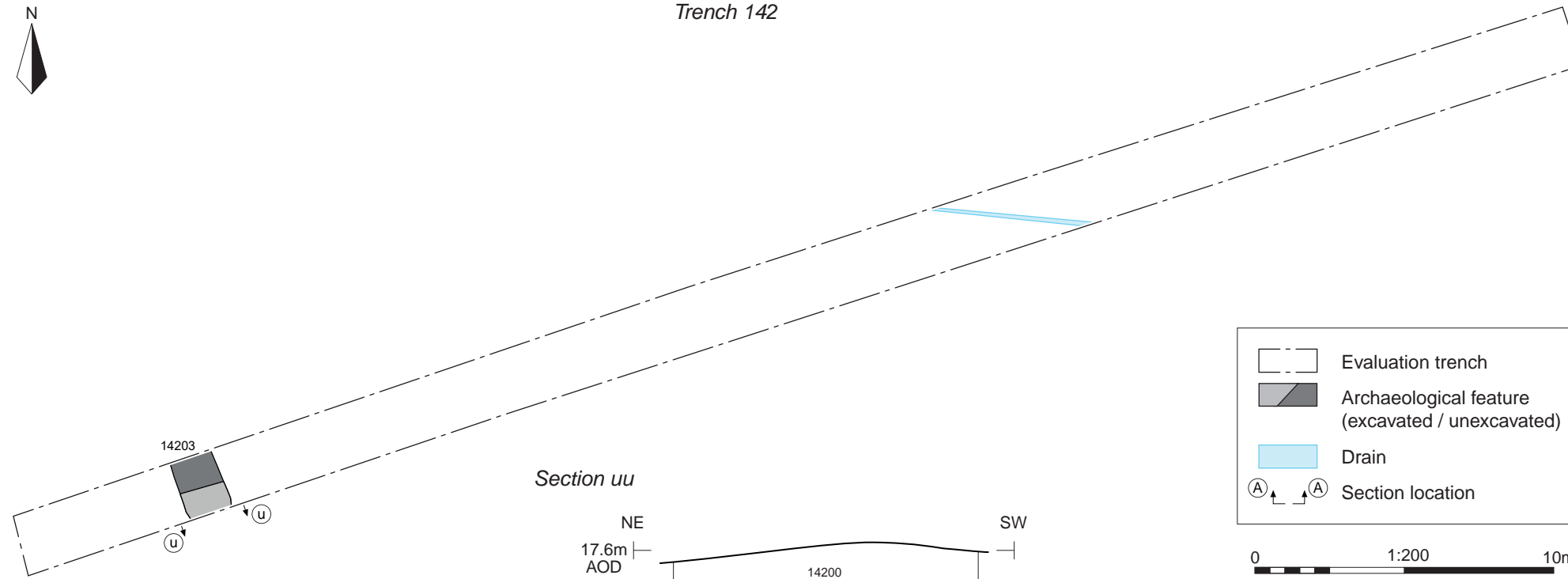

Section uu

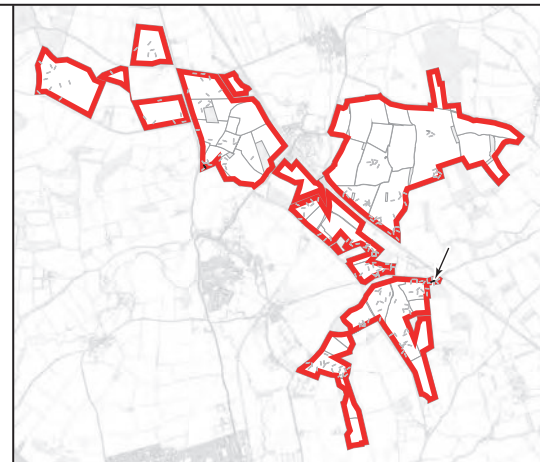
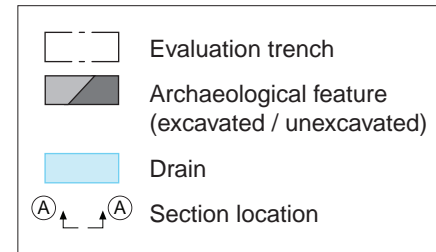
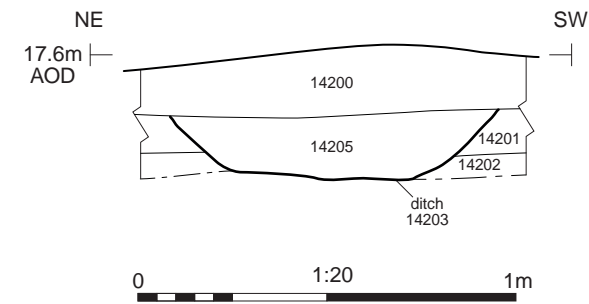

Trench 142, looking south-west (1m scales)



Ditch 14203, looking south-east (1m scale)

Cotswold Archaeology
 Andover 01264 347630
 Cirencester 01285 771022
 Milton Keynes 01908 564660
 Suffolk 01449 900120
 www.cotswoldarchaeology.co.uk
 enquiries@cotswoldarchaeology.co.uk

PROJECT TITLE
Mallard Pass Solar Farm DCO,
Essendine, Rutland & Lincolnshire

FIGURE TITLE
Area N11 (Lincolnshire), Trench 142:
plan, section and photographs

DRAWN BY	RW	PROJECT NO.	MK0789	FIGURE NO.
CHECKED BY	DJB	DATE	07/02/2023	71
APPROVED BY	AW	SCALE@A3	1:200, 1:20	

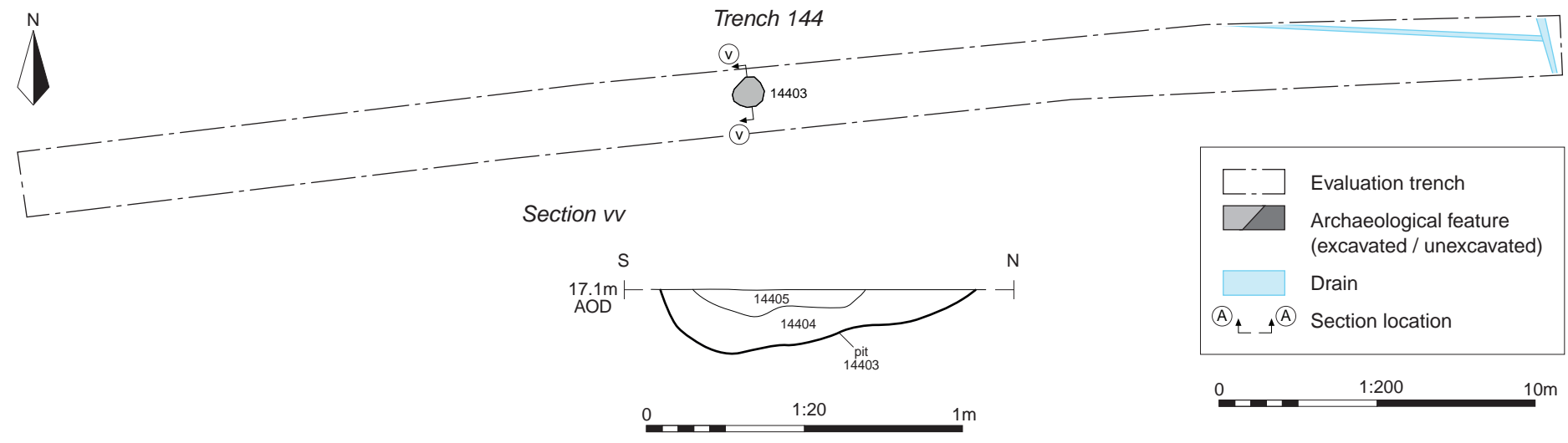
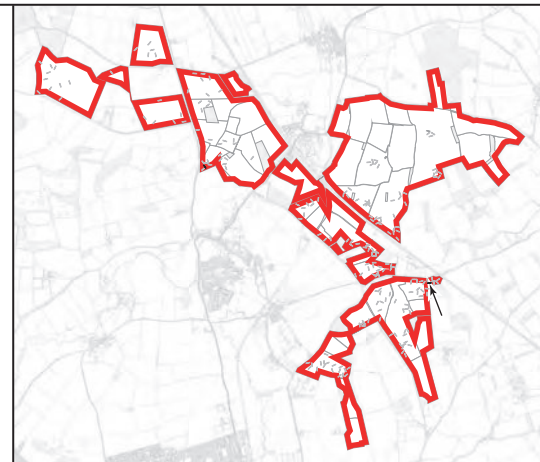

Trench 144, looking west (1m scales)



Pit 14403, looking west (0.5m scale)

 Andover 01264 347630
 Cirencester 01285 771022
 Milton Keynes 01908 564660
 Suffolk 01449 900120
 www.cotswoldarchaeology.co.uk
 enquiries@cotswoldarchaeology.co.uk

PROJECT TITLE
 Mallard Pass Solar Farm DCO,
 Essendine, Rutland & Lincolnshire

FIGURE TITLE
 Area N11 (Lincolnshire), Trench 144:
 plan, section and photographs

DRAWN BY	RW	PROJECT NO.	MK0789	FIGURE NO.
CHECKED BY	DJB	DATE	07/02/2023	72
APPROVED BY	AW	SCALE@A3	1:200, 1:20	

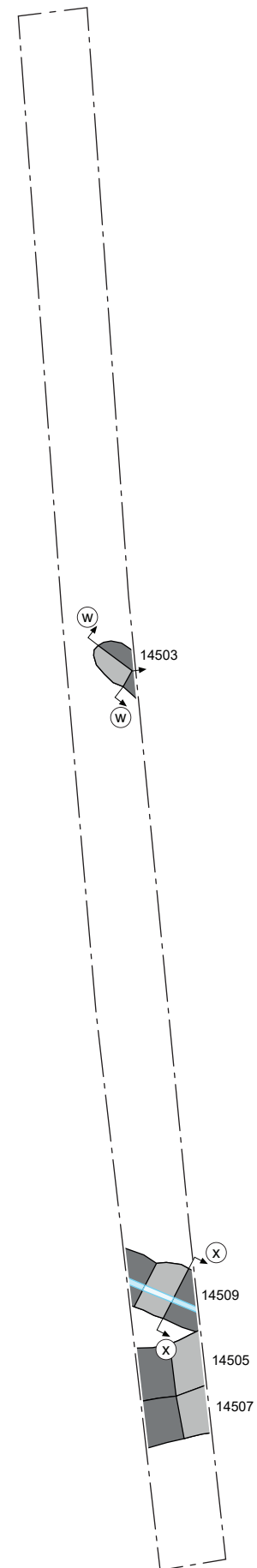

Trench 145

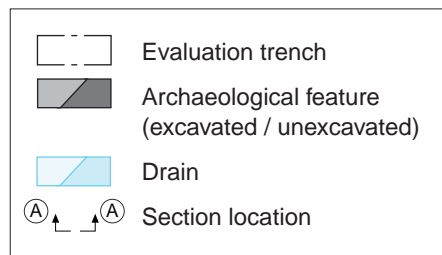

Section ww

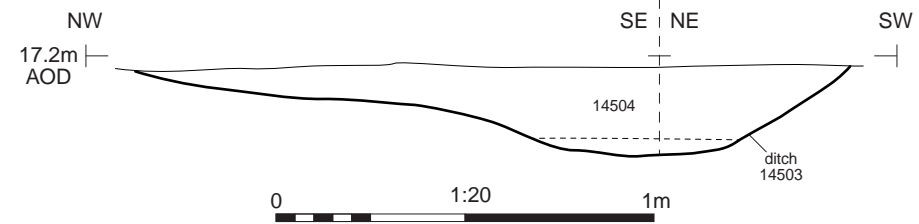

Trench 145, looking south (1m scales)



Ditch 14503, looking north-east (0.3m and 1m scale)

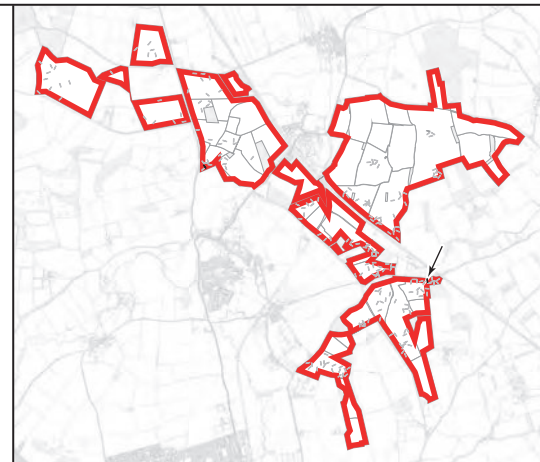

Andover 01264 347630
 Cirencester 01285 771022
 Milton Keynes 01908 564660
 Suffolk 01449 900120
 www.cotswoldarchaeology.co.uk
 enquiries@cotswoldarchaeology.co.uk

PROJECT TITLE
 Mallard Pass Solar Farm DCO,
 Essendine, Rutland & Lincolnshire

FIGURE TITLE
 Area N11 (Lincolnshire), Trench 145:
 plan, section and photographs

DRAWN BY	RW	PROJECT NO.	MK0789	FIGURE NO.
CHECKED BY	DJB	DATE	07/02/2023	73
APPROVED BY	AW	SCALE@A3	1:200, 1:20	

Section xx



Ditch 14509, looking south-east (1m scale)



Andover 01264 347630
Cirencester 01285 771022
Milton Keynes 01908 564660
Suffolk 01449 900120
www.cotswoldarchaeology.co.uk
enquiries@cotswoldarchaeology.co.uk

PROJECT TITLE

Mallard Pass Solar Farm DCO,
Essendine, Rutland & Lincolnshire

FIGURE TITLE

Area N11 (Lincolnshire), Trench 145:
section and photograph

DRAWN BY RW PROJECT NO. MK0789
CHECKED BY DJB DATE 07/02/2023
APPROVED BY AW SCALE@A4 1:20

FIGURE NO.

74

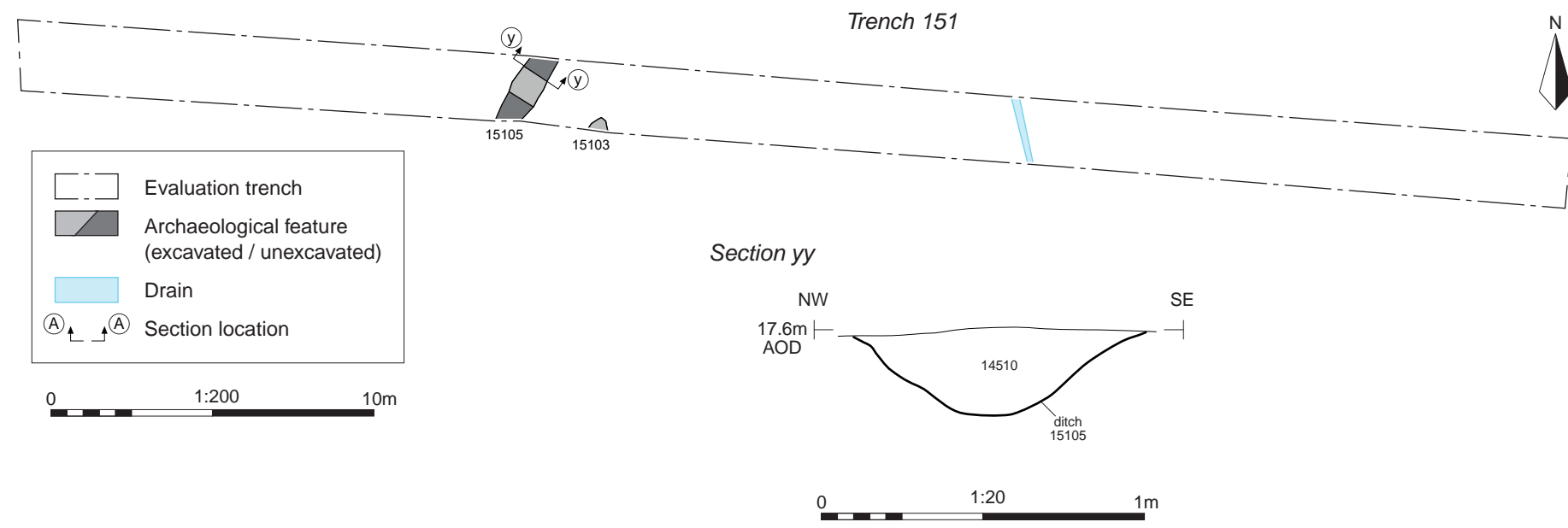
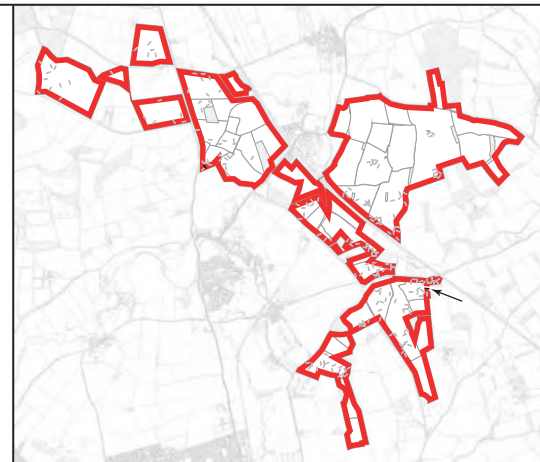

Trench 151, looking east (1m scales)



Ditch 15105, looking north-east (0.5m scale)

Cotswold Archaeology
 Andover 01264 347630
 Cirencester 01285 771022
 Milton Keynes 01908 564660
 Suffolk 01449 900120
 www.cotswoldarchaeology.co.uk
 enquiries@cotswoldarchaeology.co.uk

PROJECT TITLE
 Mallard Pass Solar Farm DCO,
 Essendine, Rutland & Lincolnshire

FIGURE TITLE
 Area N11 (Lincolnshire), Trench 151:
 plan, section and photographs

DRAWN BY	RW	PROJECT NO.	MK0789	FIGURE NO.
CHECKED BY	DJB	DATE	07/02/2023	75
APPROVED BY	AW	SCALE@A3	1:200, 1:20	



Trench 159

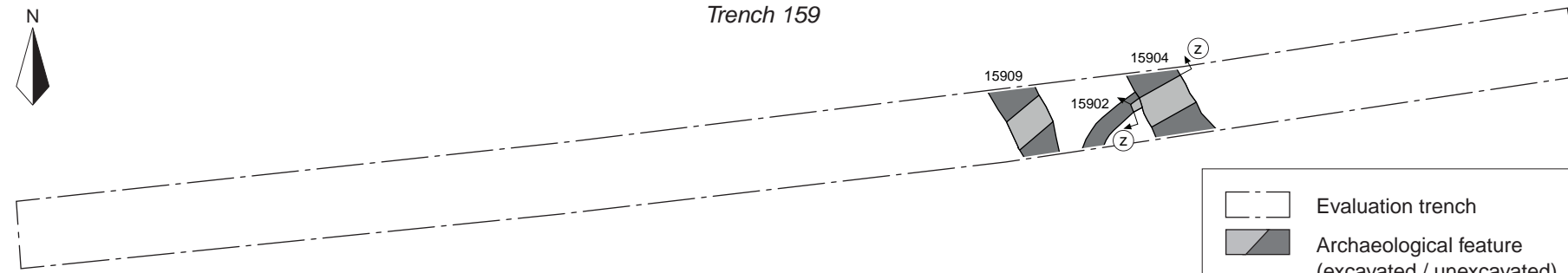

Evaluation trench
 Archaeological feature (excavated / unexcavated)
 Section location



Section zz

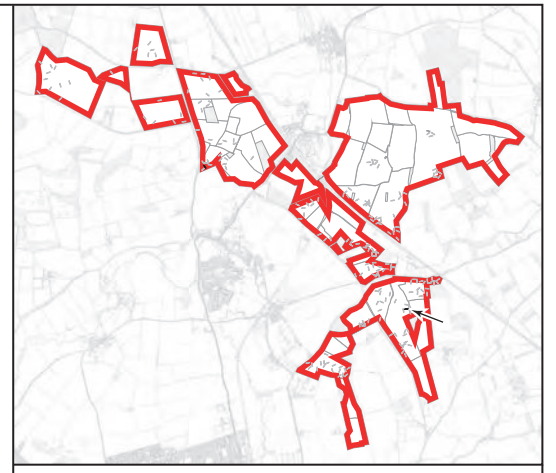
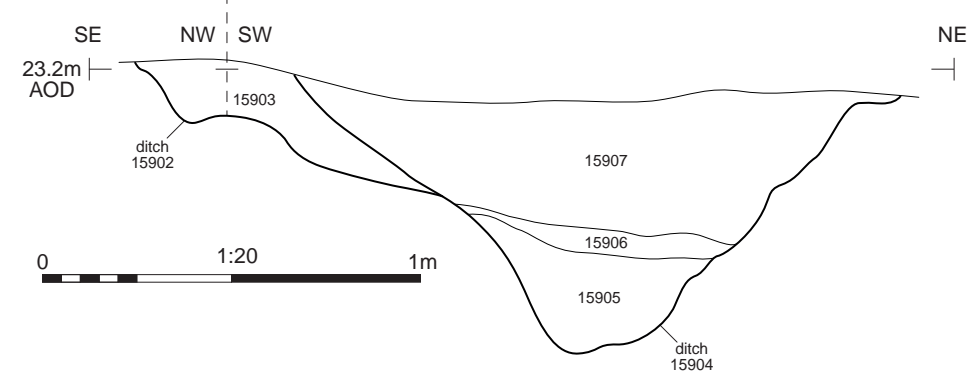

Trench 159, looking west (1m scales)



Ditches 15902 (upper-left) and 15904 (centre), looking north-west (0.2m and 1m scale)

Cotswold Archaeology
 Andover 01264 347630
 Cirencester 01285 771022
 Milton Keynes 01908 564660
 Suffolk 01449 900120
www.cotswoldarchaeology.co.uk
enquiries@cotswoldarchaeology.co.uk

PROJECT TITLE
Mallard Pass Solar Farm DCO,
Essendine, Rutland & Lincolnshire

FIGURE TITLE
Area N7 (Lincolnshire), Trench 159:
plan, section and photographs

DRAWN BY	RW	PROJECT NO.	MK0789	FIGURE NO.
CHECKED BY	DJB	DATE	07/02/2023	76
APPROVED BY	AW	SCALE@A3	1:200, 1:20	

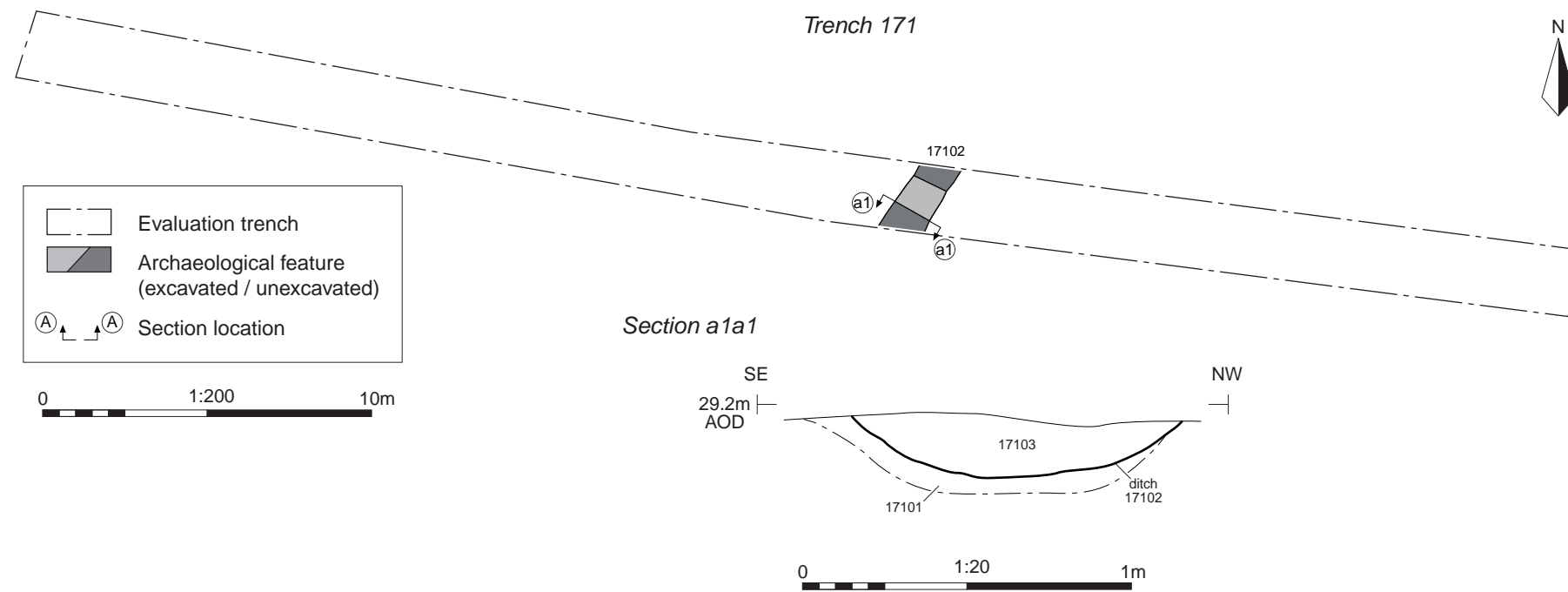
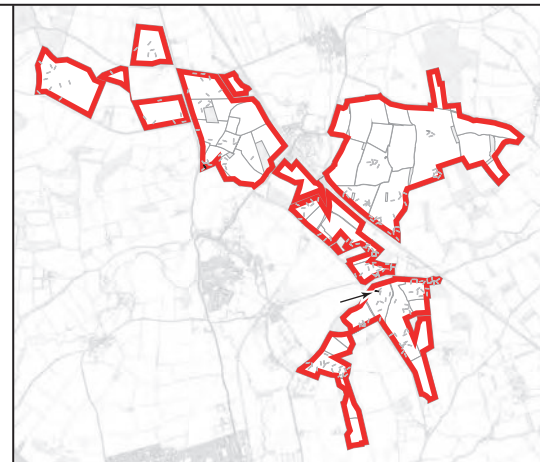

Trench 171, looking north-west (1m scales)



Ditch 17102, looking south-west (0.5m scale)

 Cotswold Archaeology
 Andover 01264 347630
 Cirencester 01285 771022
 Milton Keynes 01908 564660
 Suffolk 01449 900120
 www.cotswoldarchaeology.co.uk
 enquiries@cotswoldarchaeology.co.uk

PROJECT TITLE
 Mallard Pass Solar Farm DCO,
 Essendine, Rutland & Lincolnshire

FIGURE TITLE
 Area N7 (Lincolnshire), Trench 171:
 plan, section and photographs

DRAWN BY	RW	PROJECT NO.	MK0789	FIGURE NO.
CHECKED BY	DJB	DATE	07/02/2023	77
APPROVED BY	AW	SCALE@A3	1:200, 1:20	



Trench 177

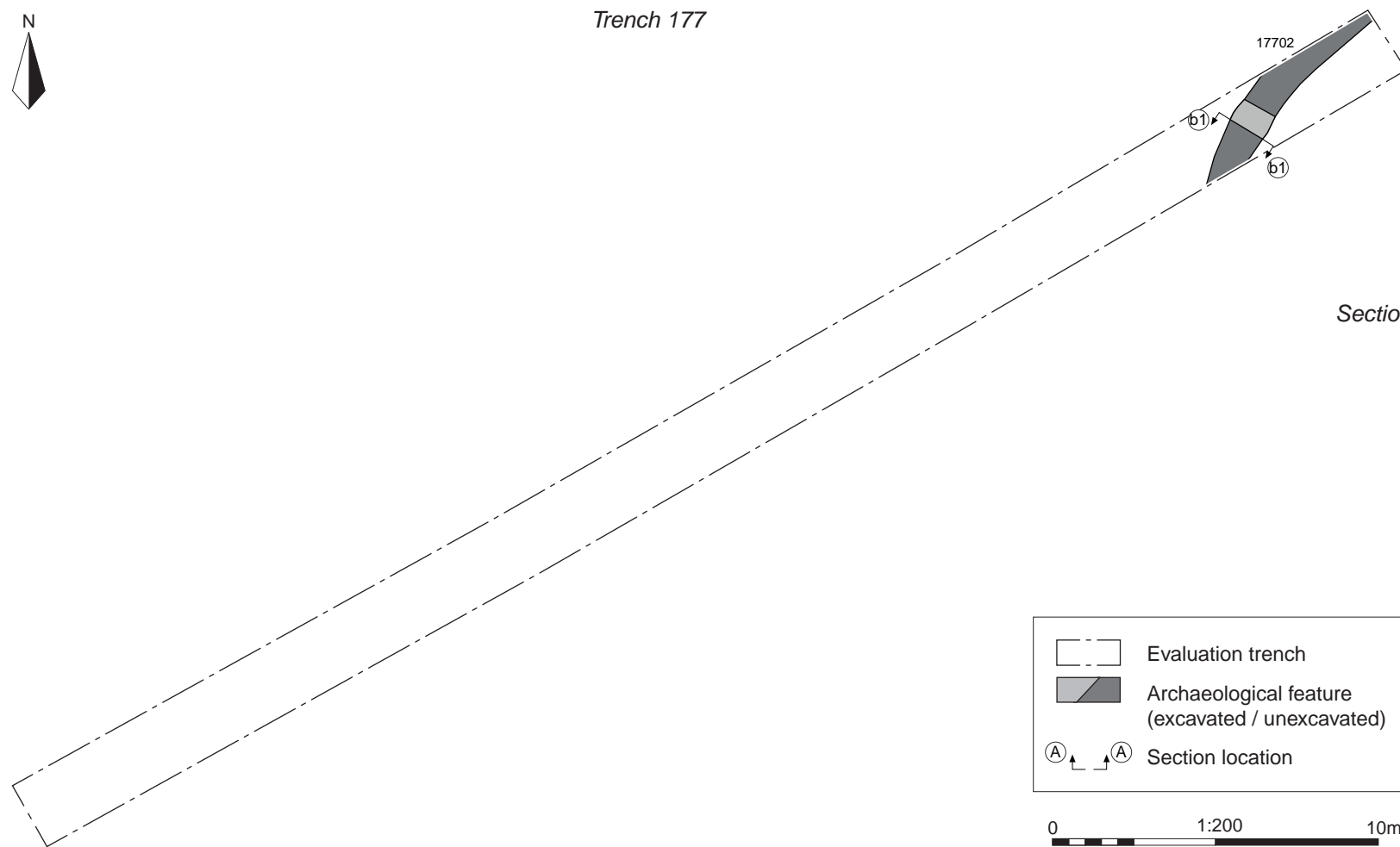

Section b1b1

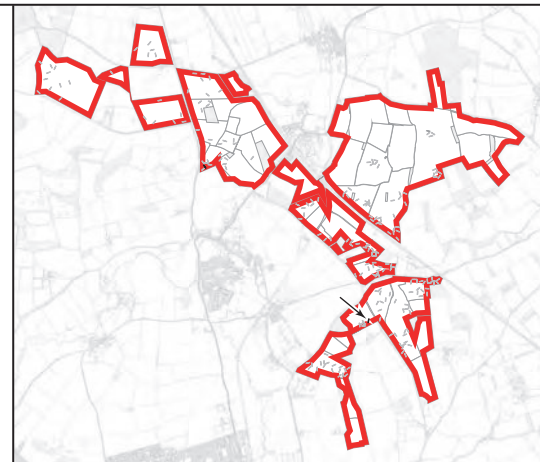
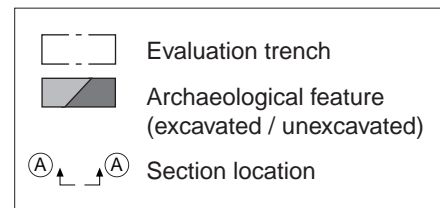
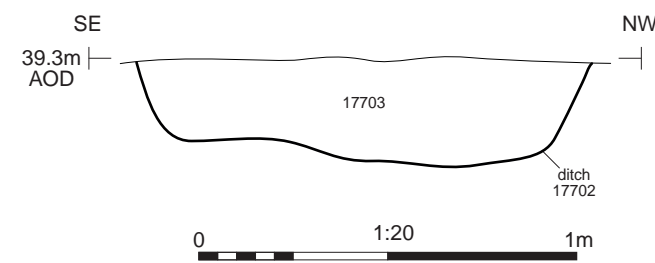

Trench 177, looking north-east (1m scales)



Ditch 17702, looking south-west (1m scale)

Cotswold Archaeology
 Andover 01264 347630
 Cirencester 01285 771022
 Milton Keynes 01908 564660
 Suffolk 01449 900120
 www.cotswoldarchaeology.co.uk
 enquiries@cotswoldarchaeology.co.uk

PROJECT TITLE
**Mallard Pass Solar Farm DCO,
 Essendine, Rutland & Lincolnshire**

FIGURE TITLE
**Area N6 (Lincolnshire), Trench 177:
 plan, section and photographs**

DRAWN BY	RW	PROJECT NO.	MK0789	FIGURE NO.
CHECKED BY	DJB	DATE	07/02/2023	78
APPROVED BY	AW	SCALE@A3	1:200, 1:20	



Trench 182

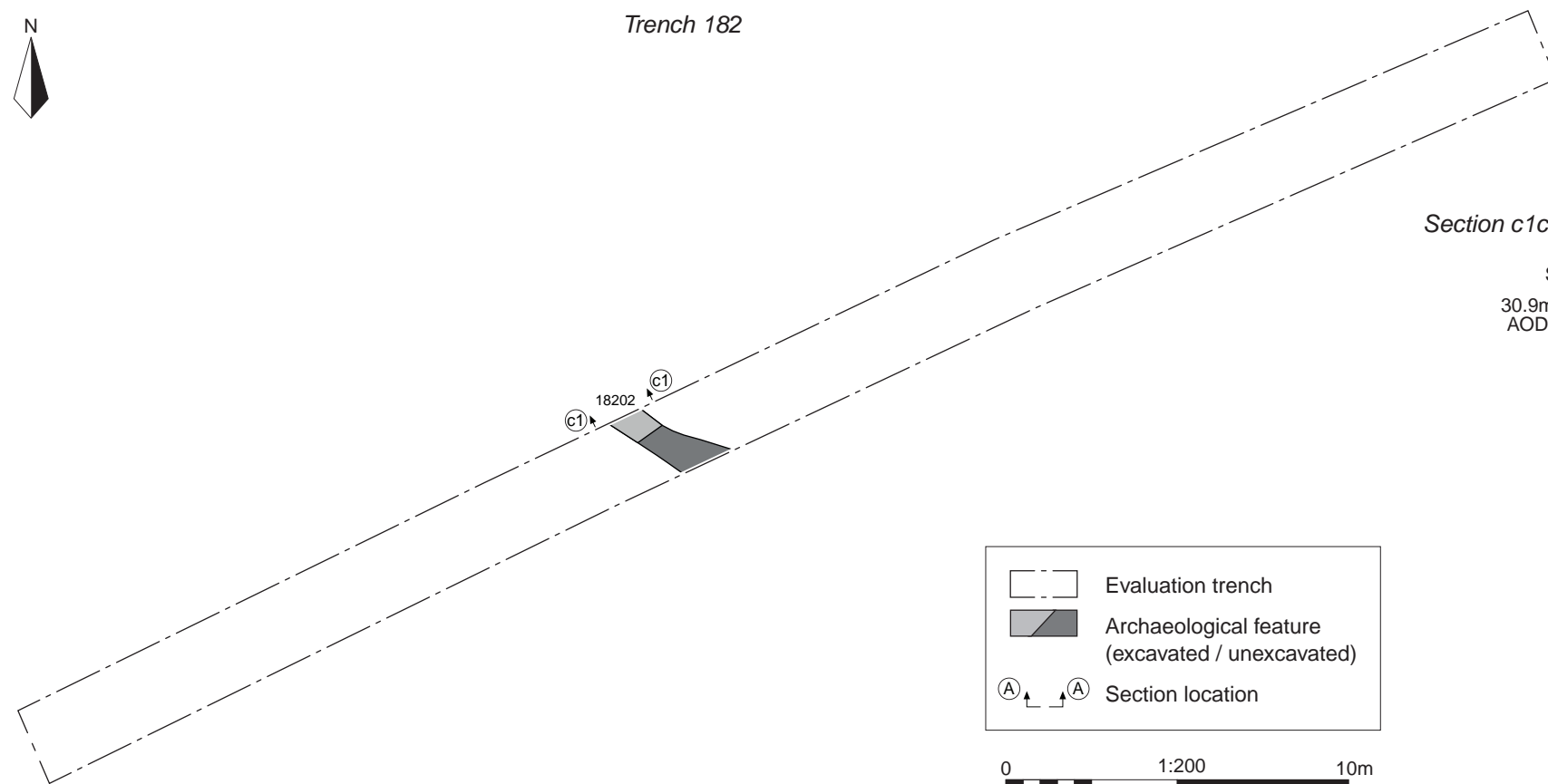

Section c1c1



Evaluation trench
 Archaeological feature (excavated / unexcavated)
 Section location

0 1:200 10m

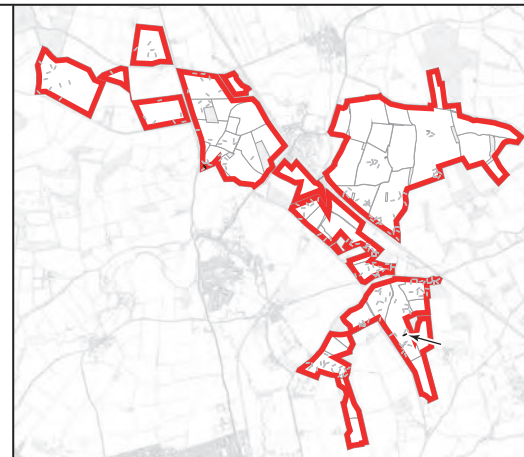

Trench 182, looking south-west (1m scales)



Ditch 18202, looking north-west (1m scale)

Cotswold Archaeology
 Andover 01264 347630
 Cirencester 01285 771022
 Milton Keynes 01908 564660
 Suffolk 01449 900120
www.cotswoldarchaeology.co.uk
enquiries@cotswoldarchaeology.co.uk

PROJECT TITLE
 Mallard Pass Solar Farm DCO,
 Essendine, Rutland & Lincolnshire

FIGURE TITLE
 Area N8 (Lincolnshire), Trench 182:
 plan, section and photographs

DRAWN BY RW PROJECT NO. MK0789 FIGURE NO.
 CHECKED BY DJB DATE 07/02/2023
 APPROVED BY AW SCALE@A3 1:200, 1:20 79

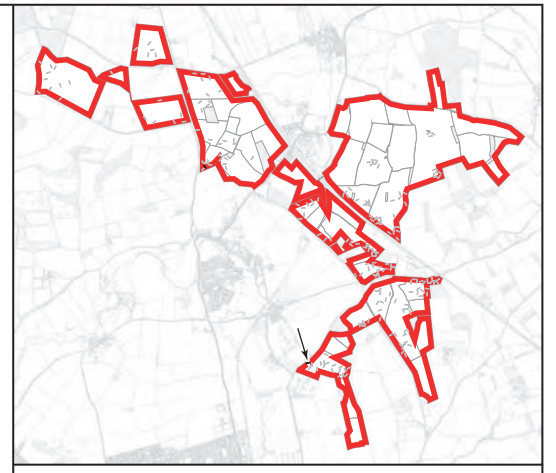
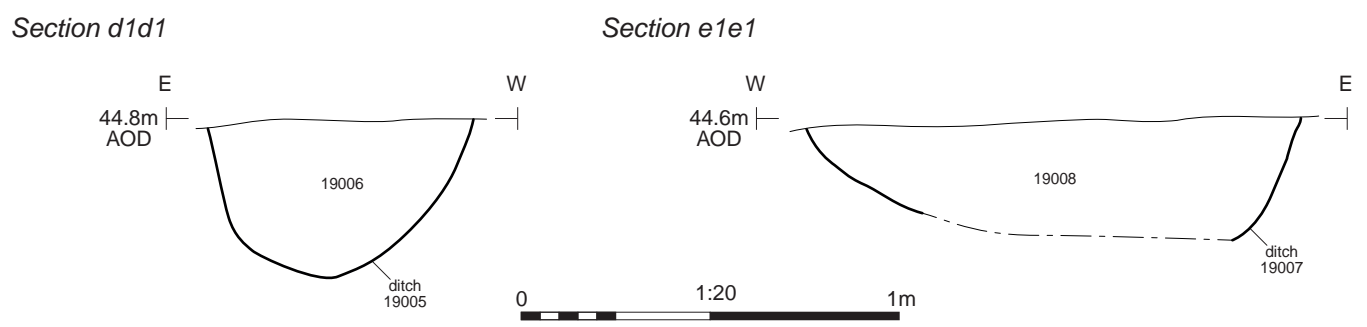
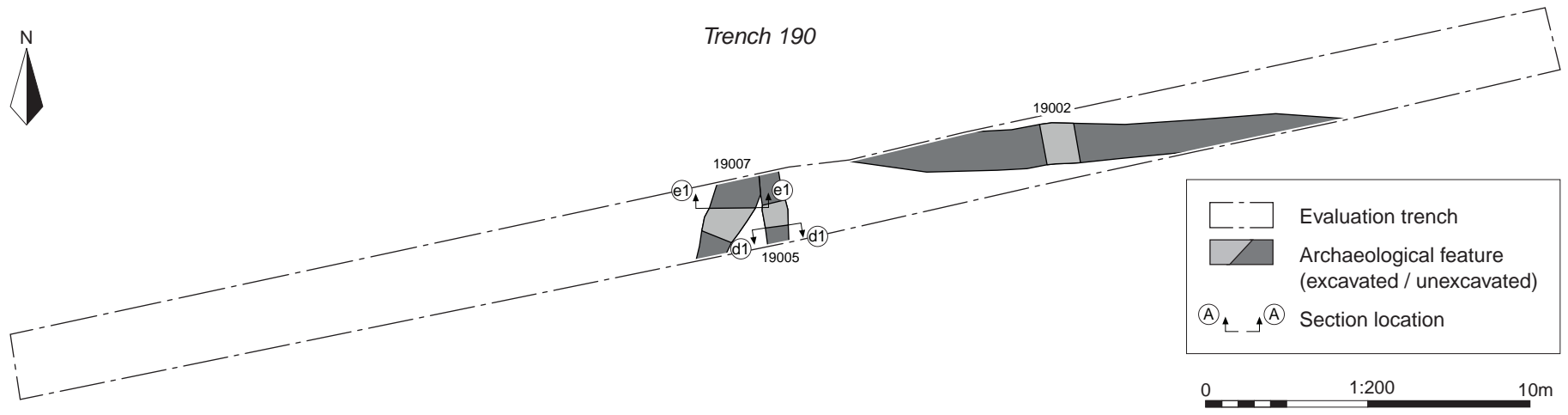

Trench 190, looking south-west (1m scales)



Ditches 19007 (upper-left) and 19006 (lower-right), looking north-west (0.5m and 1m scale)

Cotswold Archaeology
 Andover 01264 347630
 Cirencester 01285 771022
 Milton Keynes 01908 564660
 Suffolk 01449 900120
 www.cotswoldarchaeology.co.uk
 enquiries@cotswoldarchaeology.co.uk

PROJECT TITLE
**Mallard Pass Solar Farm DCO,
 Essendine, Rutland & Lincolnshire**

FIGURE TITLE
**Area N3 (Lincolnshire), Trench 190:
 plan, sections and photographs**

DRAWN BY	RW	PROJECT NO.	MK0789	FIGURE NO.
CHECKED BY	DJB	DATE	07/02/2023	80
APPROVED BY	AW	SCALE@A3	1:200, 1:20	

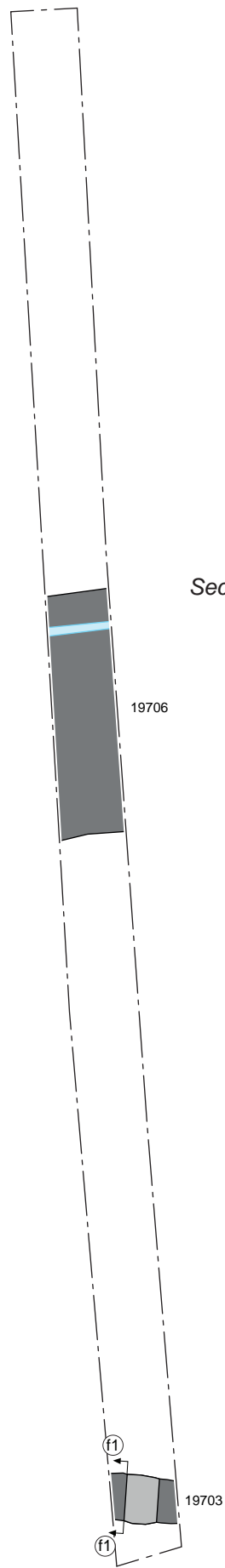

Trench 197



Section f1f1

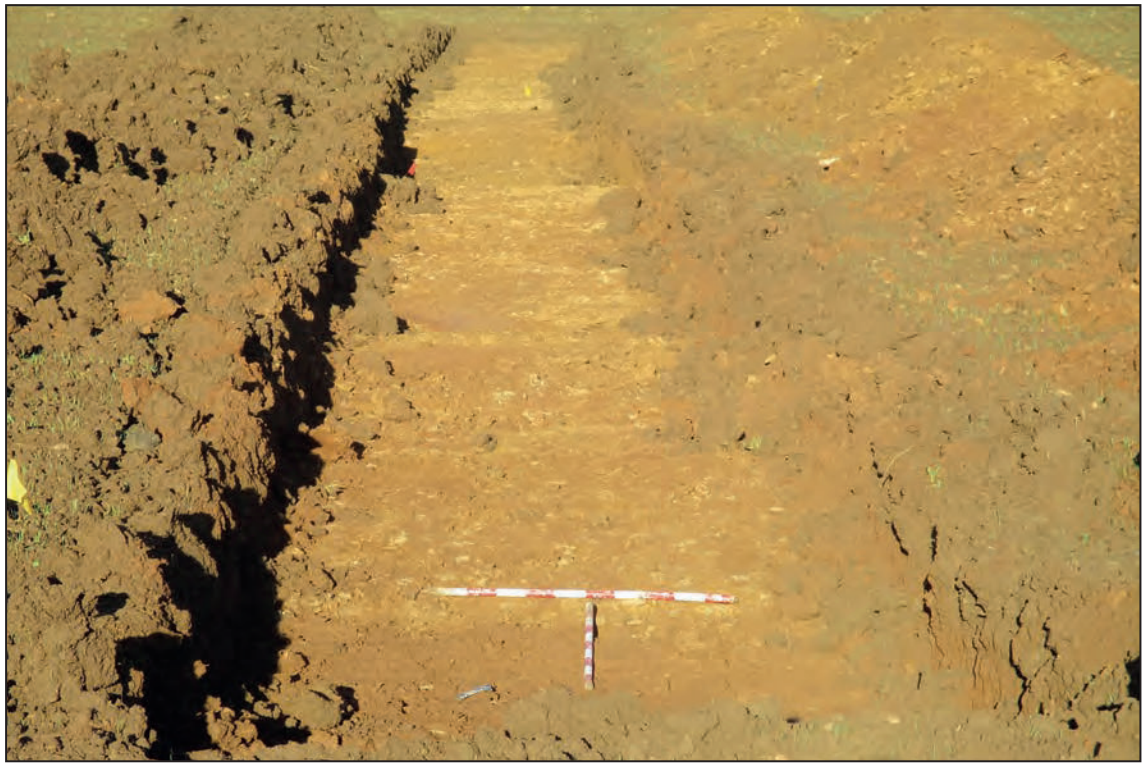
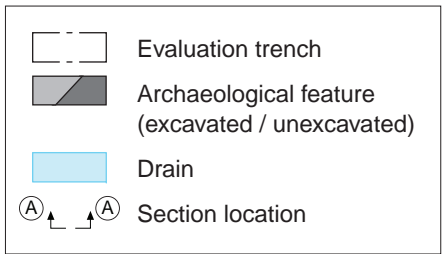
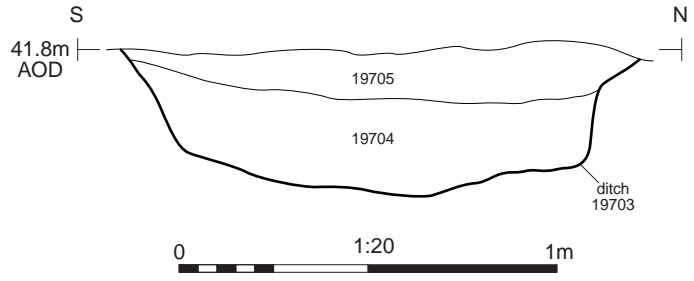

Trench 190, looking south-west (1m scales)



Ditch 19703, looking west (1m scale)



 Andover 01264 347630
 Cirencester 01285 771022
 Milton Keynes 01908 564660
 Suffolk 01449 900120
www.cotswoldarchaeology.co.uk
enquiries@cotswoldarchaeology.co.uk

PROJECT TITLE
 Mallard Pass Solar Farm DCO,
 Essendine, Rutland & Lincolnshire

FIGURE TITLE
 Area N3 (Lincolnshire), Trench 197:
 plan, section and photographs

DRAWN BY	RW	PROJECT NO.	MK0789	FIGURE NO.
CHECKED BY	DJB	DATE	07/02/2023	81
APPROVED BY	AW	SCALE@A3	1:200, 1:20	



Trench 204

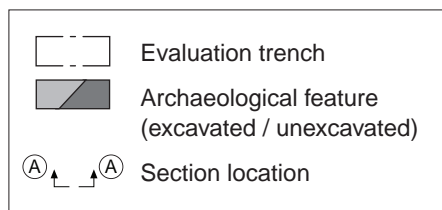
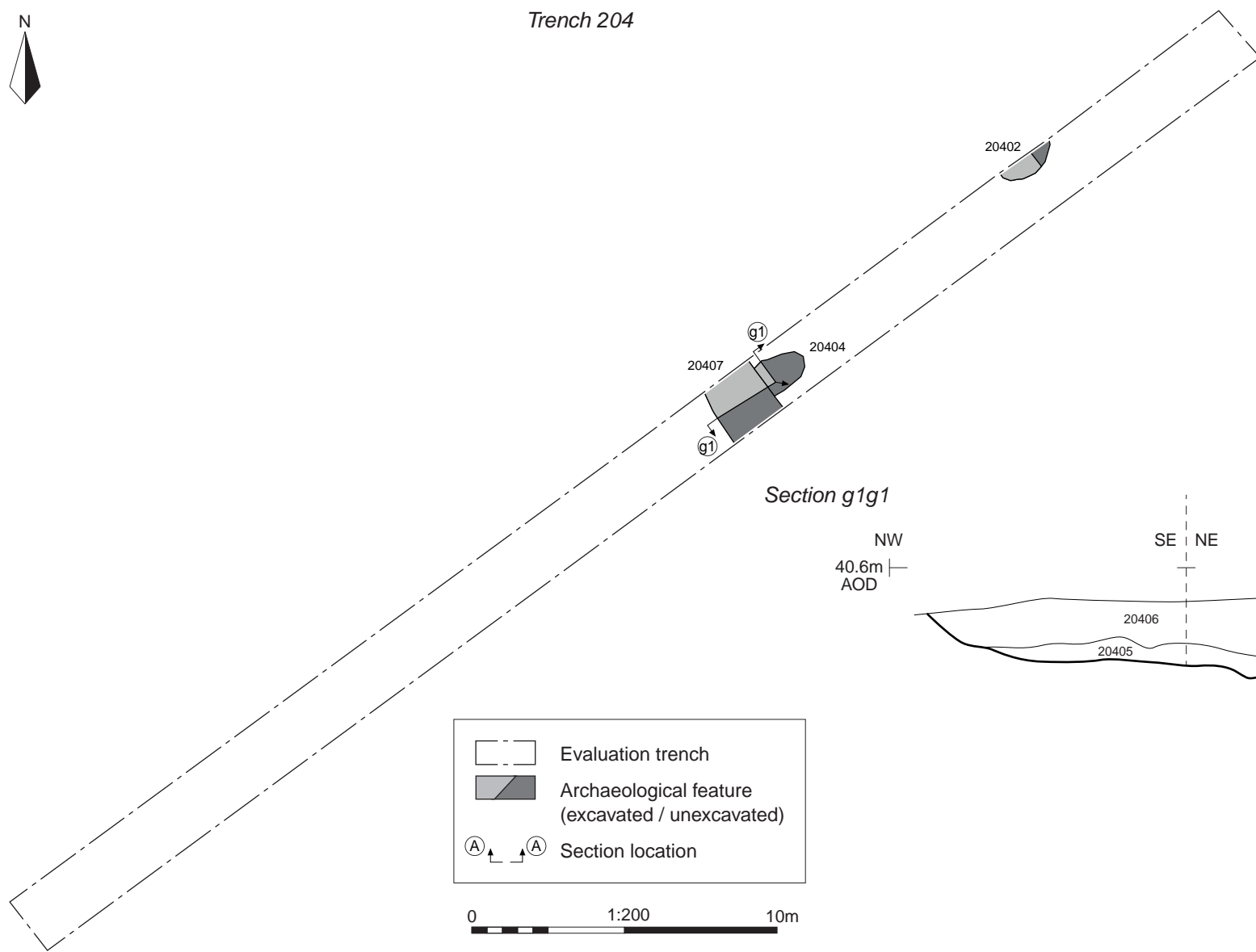

Section g1g1

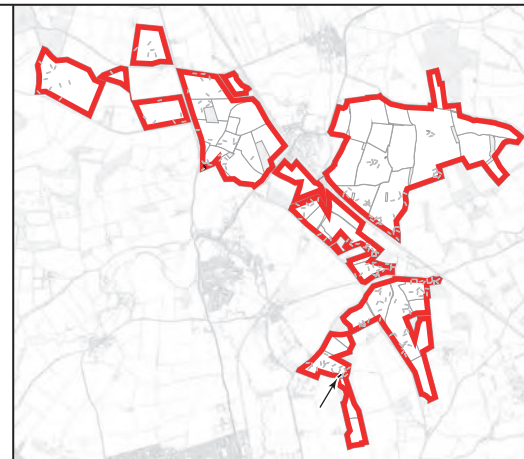
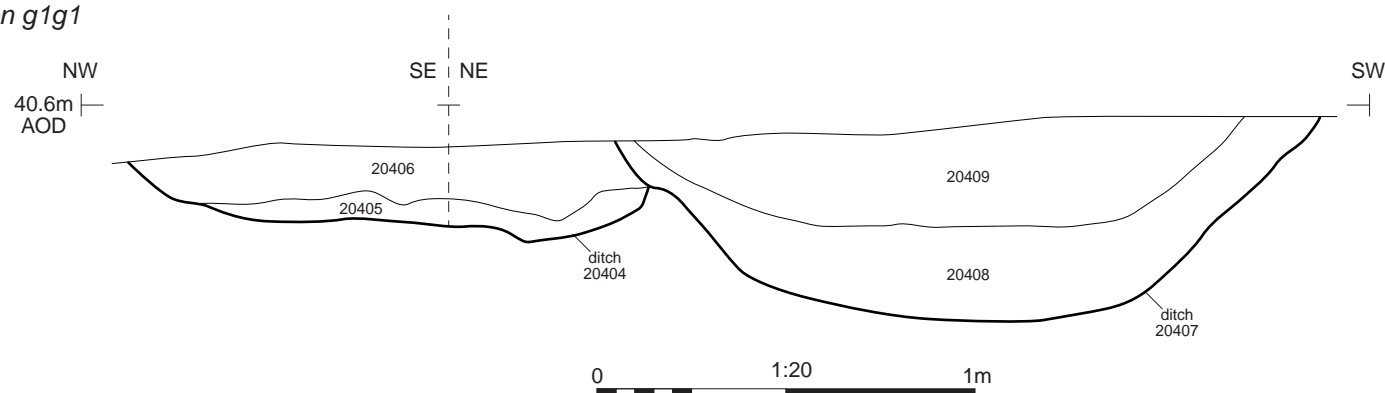

Trench 204, looking south-east (1m scales)



Ditches 20404 (left) and 20407 (right), looking south-east (1m scales)

Cotswold Archaeology
 Andover 01264 347630
 Cirencester 01285 771022
 Milton Keynes 01908 564660
 Suffolk 01449 900120
www.cotswoldarchaeology.co.uk
enquiries@cotswoldarchaeology.co.uk

PROJECT TITLE
Mallard Pass Solar Farm DCO,
Essendine, Rutland & Lincolnshire

FIGURE TITLE
Area N3 (Lincolnshire), Trench 204:
plan, section and photographs

DRAWN BY	RW	PROJECT NO.	MK0789	FIGURE NO.
CHECKED BY	DJB	DATE	07/02/2023	82
APPROVED BY	AW	SCALE@A3	1:200, 1:20	

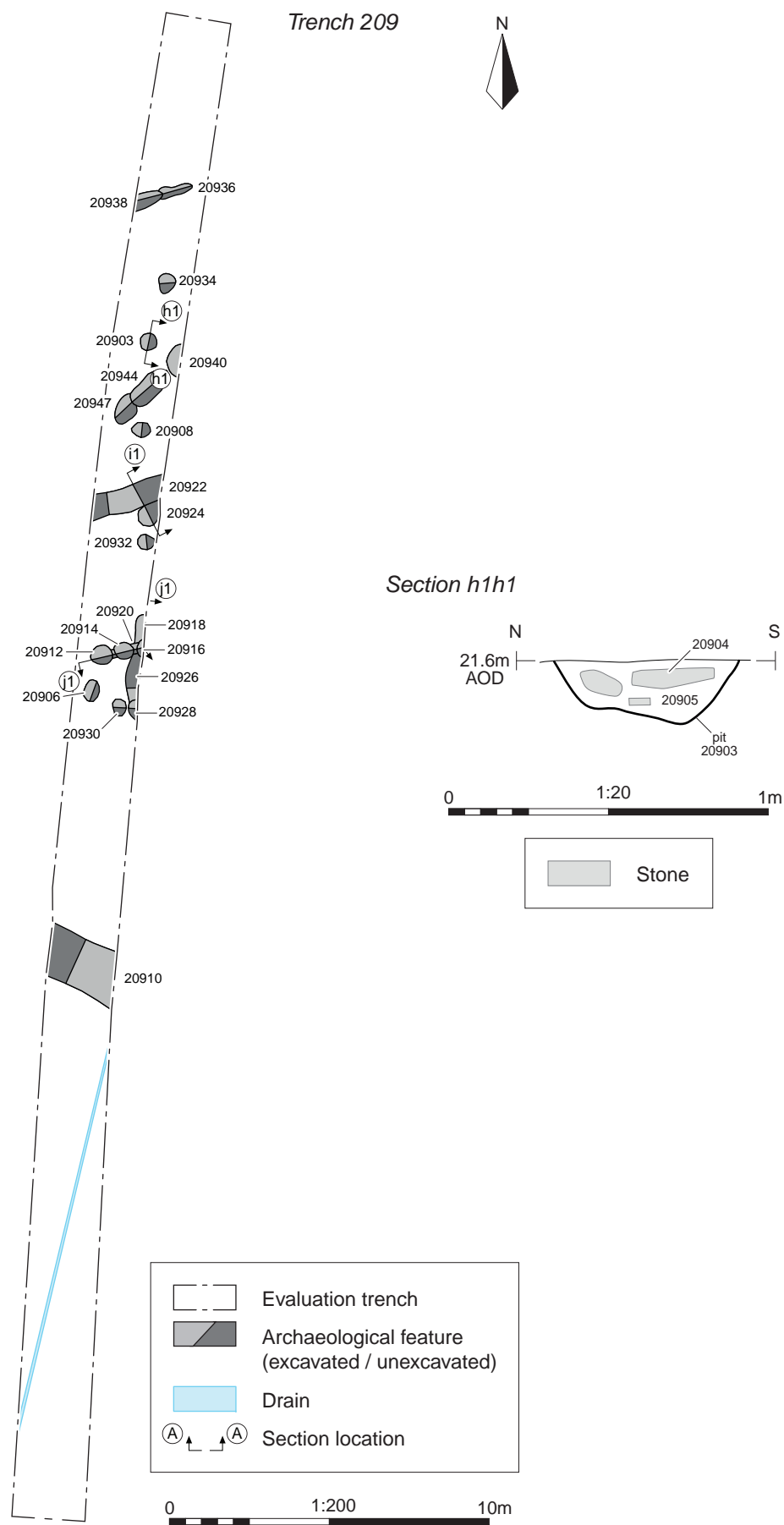
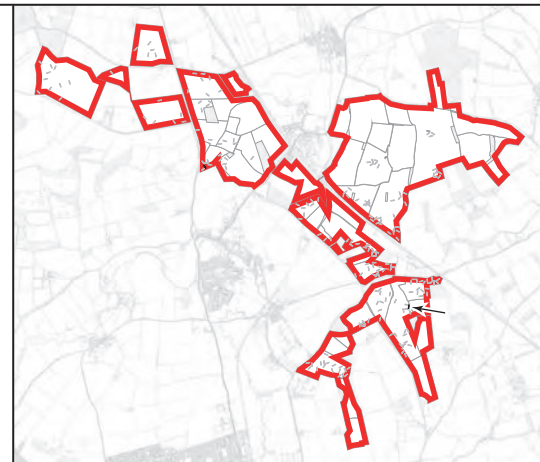

Trench 209, looking north (1m scale)



Pit 20903, looking east (0.5m scale)

Andover 01264 347630
 Cirencester 01285 771022
 Milton Keynes 01908 564660
 Suffolk 01449 900120
www.cotswoldarchaeology.co.uk
enquiries@cotswoldarchaeology.co.uk

PROJECT TITLE
 Mallard Pass Solar Farm DCO,
 Essendine, Rutland & Lincolnshire
FIGURE TITLE
 Area N7 (Lincolnshire), Trench 209:
 plan, section and photographs

DRAWN BY	RW	PROJECT NO.	MK0789	FIGURE NO.
CHECKED BY	DJB	DATE	07/02/2023	83
APPROVED BY	AW	SCALE@A3	1:200, 1:20	

Section i1i1

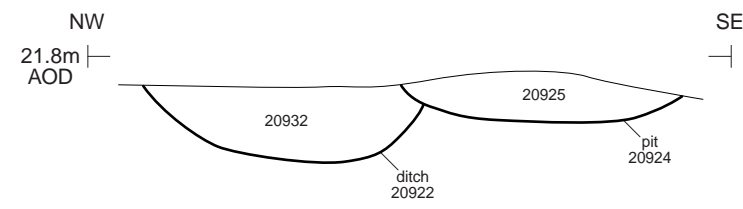

Section j1j1

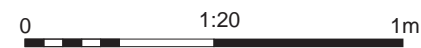
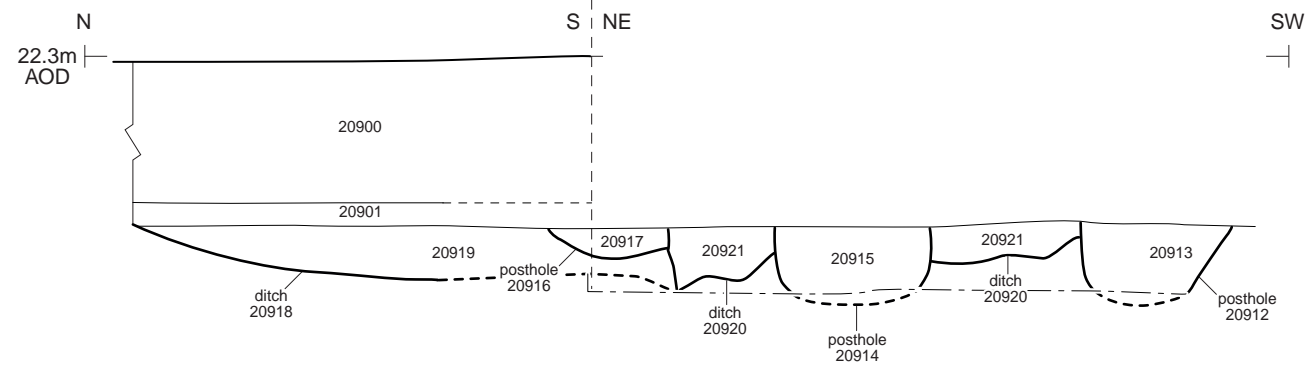

Ditch 20922 (left) and 20924 (right), looking north-east (1m scale)

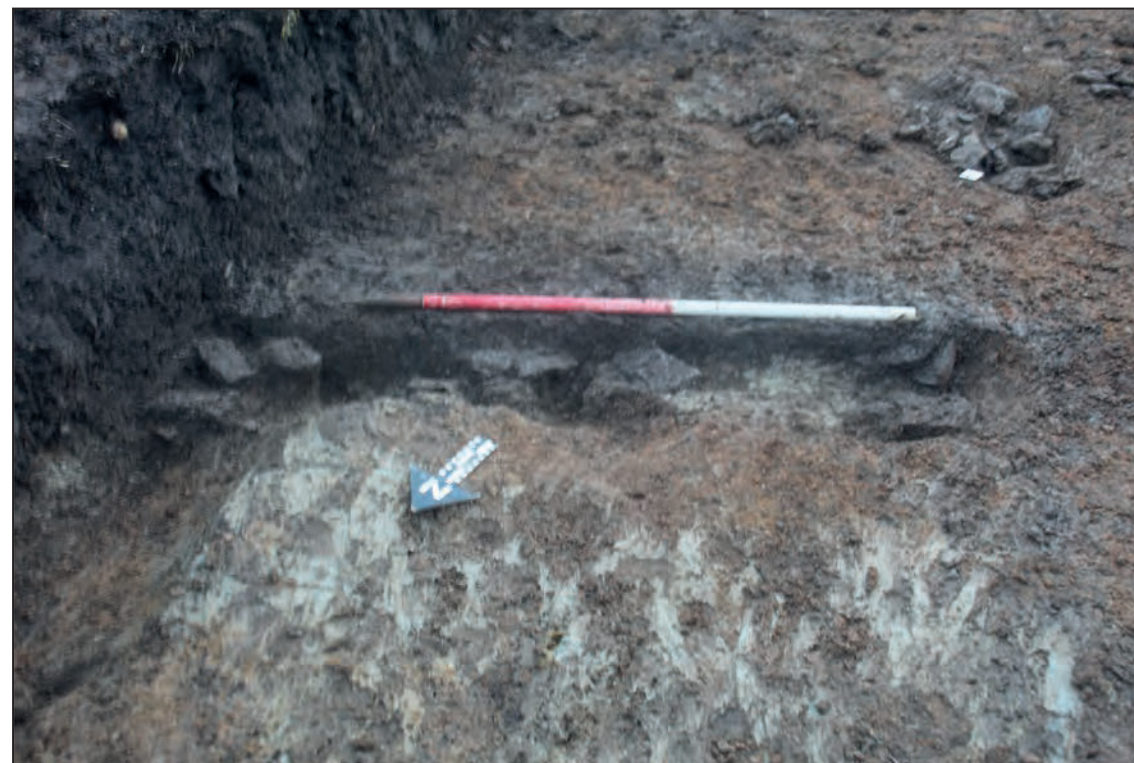

Ditches 20918 and 20920, and postholes 20916, 20914 and 20912 (left to right), looking south-east (1m scale)

Cotswold Archaeology
 Andover 01264 347630
 Cirencester 01285 771022
 Milton Keynes 01908 564660
 Suffolk 01449 900120
www.cotswoldarchaeology.co.uk
enquiries@cotswoldarchaeology.co.uk

PROJECT TITLE
 Mallard Pass Solar Farm DCO,
 Essendine, Rutland & Lincolnshire

FIGURE TITLE
 Area N3 (Lincolnshire), Trench 197:
 plan, section and photographs

DRAWN BY	RW	PROJECT NO.	MK0789	FIGURE NO.
CHECKED BY	DJB	DATE	07/02/2023	84
APPROVED BY	AW	SCALE@A3	1:20	

Andover Office

Stanley House
Walworth Road
Andover
Hampshire
SP10 5LH

t: 01264 347630

Cirencester Office

Building 11
Cotswold Business Park
Cirencester
Gloucestershire
GL7 6BQ

t: 01285 771022

Milton Keynes Office

Unit 8 - The IO Centre
Fingle Drive, Stonebridge
Milton Keynes
Buckinghamshire
MK13 0AT

t: 01908 564660

Suffolk Office

Unit 5, Plot 11, Maitland Road
Lion Barn Industrial Estate
Needham Market
Suffolk
IP6 8NZ

t: 01449 900120

e: enquiries@cotswoldarchaeology.co.uk



